



Stock code: 6237

Trade name: IWAKI CO.,LTD.

Company briefing materials

**I . Supplementary Information . . . . p 3**

**II . Our Strengths . . . . p11**

**III . Our Strategies . . . . p22**



**I**

# **Supplementary Information**



<b>Name of company</b>	<b>IWAKI CO., LTD.</b>  Professional and comprehensive manufacturer of <b>Chemical pumps</b>
<b>Establishment</b>	April 10,1956
<b>President</b>	Shigeru Fujinaka
<b>Head office</b>	2-6-6, Kanda Suda-cho, Chiyoda-ku, Tokyo
<b>Capital</b>	1,044,691,100 yen
<b>Number of employees</b>	1,124
<b>Business description</b>	Development, production and sales of chemical pumps, various fluid control products etc.
<b>Listed exchange</b>	Tokyo Stock Exchange Prime Market



## **President Shigeru Fujinaka**

---

Born on December 20, 1964

Birthplace : Saitama, Japan

### **【 Career 】**

- 1989 Joined IWAKI
- 2006 General Manager of Planning and Promotion Department, Engineering Head Office
- 2007 Executive Director and General Manager of Corporate Planning Office
- 2008 Senior Executive Director
- 2009 President

## The Iwaki Pledge

Our mission is to always be at the forefront of efforts to advance development in the global markets, industries and communities where we operate while building trust with, and contributing to the happiness of everyone we interact with.

---

## Corporate Identity

# The Heart of Industry

**A strong commitment** to  
contribute to industrial progress

Chemical pumps...  
**The heart** of industry

**1956** Established for sales of physical and chemical appliances

**1959** Started to manufacture and sell chemical pumps



イワキ創業者 藤中義昭

1966 Established Tokyo plant (present System office) in Saitama

1974 Established Saitama plant in Sayama, Saitama

1977 Established Miharu plant in Miharu, Fukushima

1985 Established Iwaki Europe GmbH, a sales company, in Europe

1991 Established IWAKI WALCHEM CORPORATION, a sales company, in U.S.A.

2008 Acquired WALCHEM CORPORATION and changed the trade name to Iwaki America Incorporated

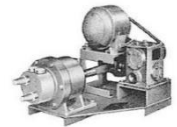

**2016** Listed on the Second Section of the Tokyo Stock Exchange

2016 Dec. Acquired TechnoEcho Co., Ltd. and made it a subsidiary

2018 Established new technology center (in Iruma, Saitama)



**2019** Moved to the First Section of the Tokyo Stock Exchange

2020 Iwaki Europe GmbH acquired the shares of IWAKI NORDIC A/S and made it a subsidiary

2021 Absorbed and merged TechnoEcho Co., Ltd.



**2022** Moved to the Prime Market of the Tokyo Stock Exchange

2022 Sep. Acquired shares of Iwaki Pumps Co., Ltd. including its subsidiaries and Iwaki Pumps (Shanghai) Co., Ltd.



## Sales

(Billions of yen)

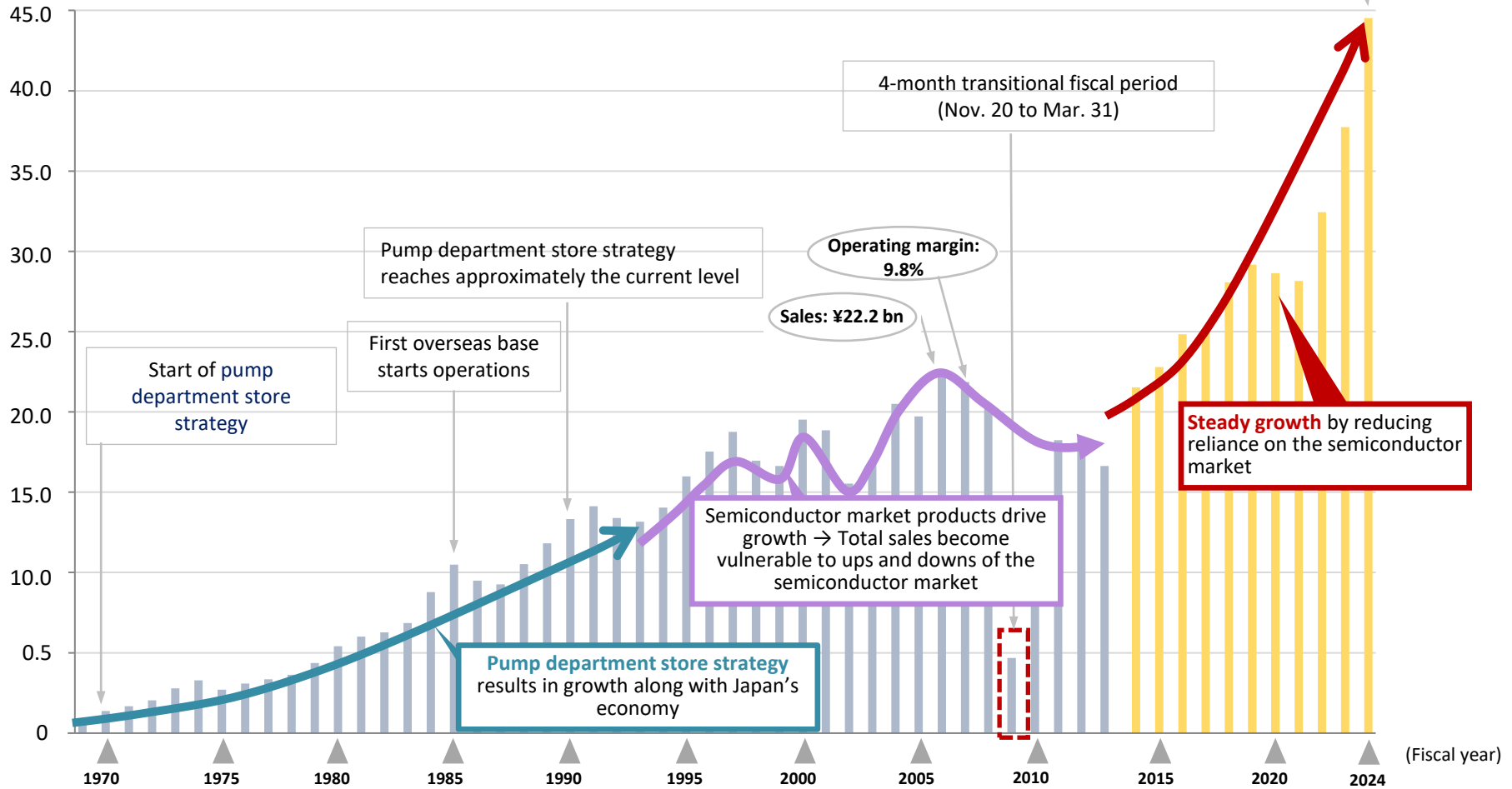

Non-consolidated Sales

Consolidated sales





**Chemical pumps** are used for the transmission of chemicals and other substances



Unlike water pumps, chemical pumps are used for the transmission of many types of liquids, including sulfuric acid and other hazardous chemicals.



Chemical pumps must meet

**very high safety standards**

(No leaks)

**Chemical pumps** that play an active role behind the scenes

## Electric power (Wind farm)



At wind farms, pumps are used for circulating transformer cooling oil.

## Foods



Pumps are used for transferring ketchup, mayonnaise, syrup, chocolate, etc. Also used for injecting liquid fertilizer in cultivation of vegetables or fruits.

## Technology



Pumps are used in the process of manufacturing semiconductors that are indispensable to digital devices such as smartphones, tablets, PC, digital home appliances, etc.

## Infrastructure (Tap water)



At filtration plants, pumps are used for injecting chemicals in the process of water treatment. That helps people to be able to drink tap water at home without worries.

## Medical field



Pumps are installed in artificial dialysis devices, biochemical analyzers. In that way, our pumps support the medical field.

## Entertainment



Used at;  
Aquariums to control the quality of water to keep the environment suitable for animals.  
Swimming pools or spas to control the quality of water to help people to use without worries.  
Theaters for circulating cooling water to protect cinema projectors.

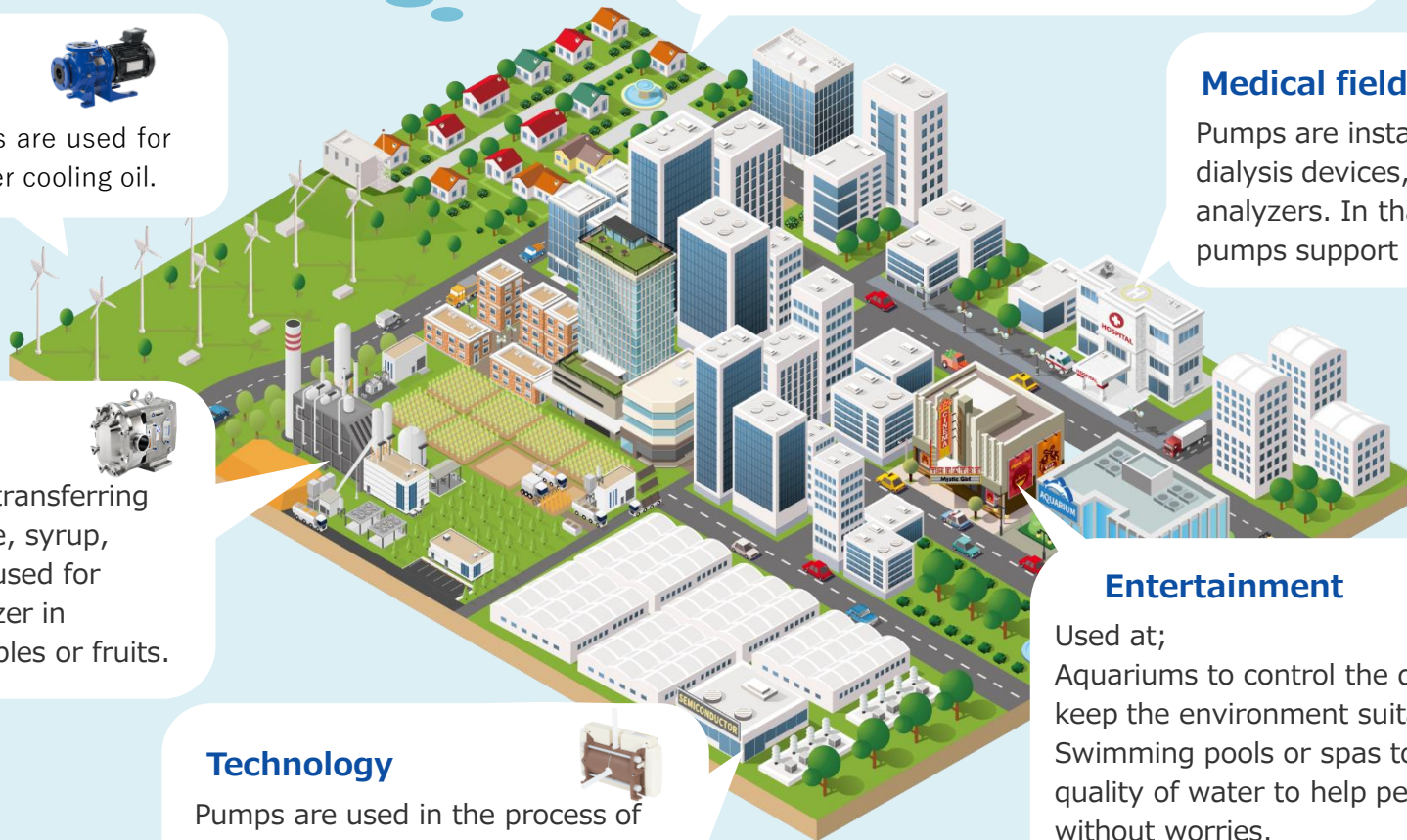

**II**

# **Our Strengths**

**1**

**Abundant product lineup to meet customers' requirements**

**2**

**Strong customer support backed by a global production, sales and support infrastructure**

**3**

**Ability to create solutions using fluid control functions centered on pumps**

**More than 60 series** of pump models and **tens of thousands of models**  
A **one-stop source** of comprehensive solutions for a broad array of pumps

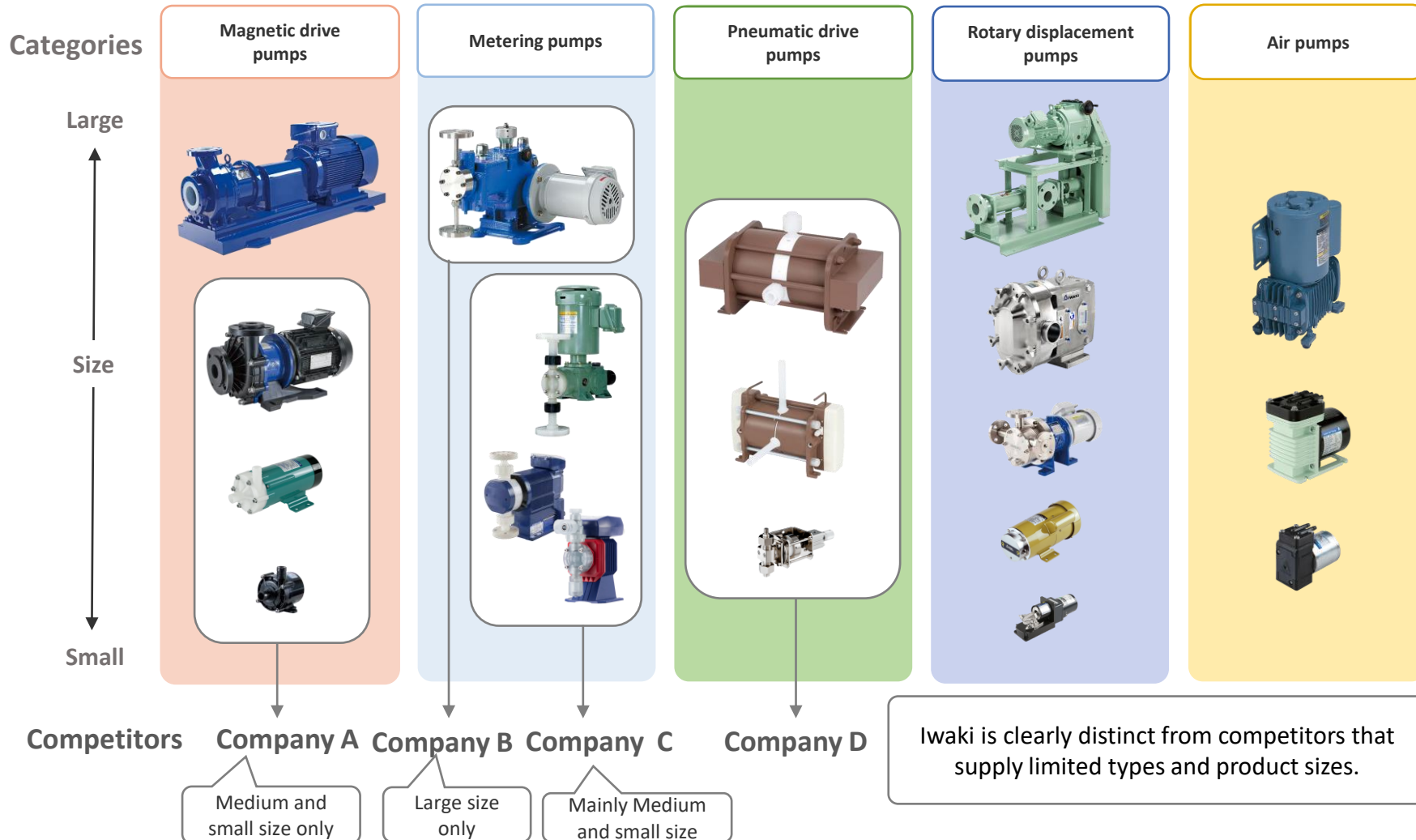

we offer a variety of product series from small-size to large-size to fit the customers' various applications

ex) Magnetic drive pumps

## Palm size

1 liter / min

Direct drive pumps NRD series



## World's largest class

5,000 liter / min

Magnetic drive pumps MDW series

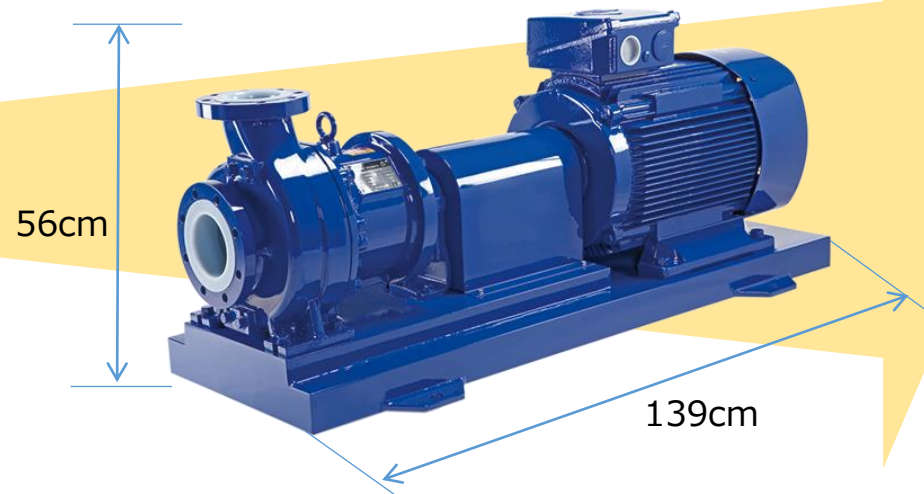

## Small pump

= Installed in the customers' devices



CT scanner



Beauty laser



Biochemical analyzer



Large cinema projector

## Large pump

= Used at a plant, etc.









Chemical factory



Various plants



## Multi-Market Sales is one of the advantages of our company.

Multi-Market Sales	Main pump applications	Magnetic drive pumps 	Metering pumps 	Pneumatic drive pump 	Rotary displacement pumps 	Air pumps 	System products 
Semiconductor / liquid crystal market	Semiconductor manufacturing equipment, etc.	●	○	●			○
Medical equipment market	Dialysis equipment, clinical analyzers, etc.	○	○		●	●	○
Surface treatment equipment market	Printed circuit board manufacturing equipment, electronic component manufacturing, etc.	●	○				○
Chemicals market	Chemical manufacturing, etc.	●	○		○		○
Water treatment market	Waterworks, wastewater treatment plants, cooling towers, etc.	○	●		○	○	○
New energy market	Renewable energy, secondary battery manufacturing, etc.	○	○		●		○
Others (Food, paper, others)	Food manufacturing, various cooling applications, etc.	○	○		●	○	○

※Filled circle: main pumps in each market



## Sales scale of core products

Sales (Results for the year ended in March 2024)

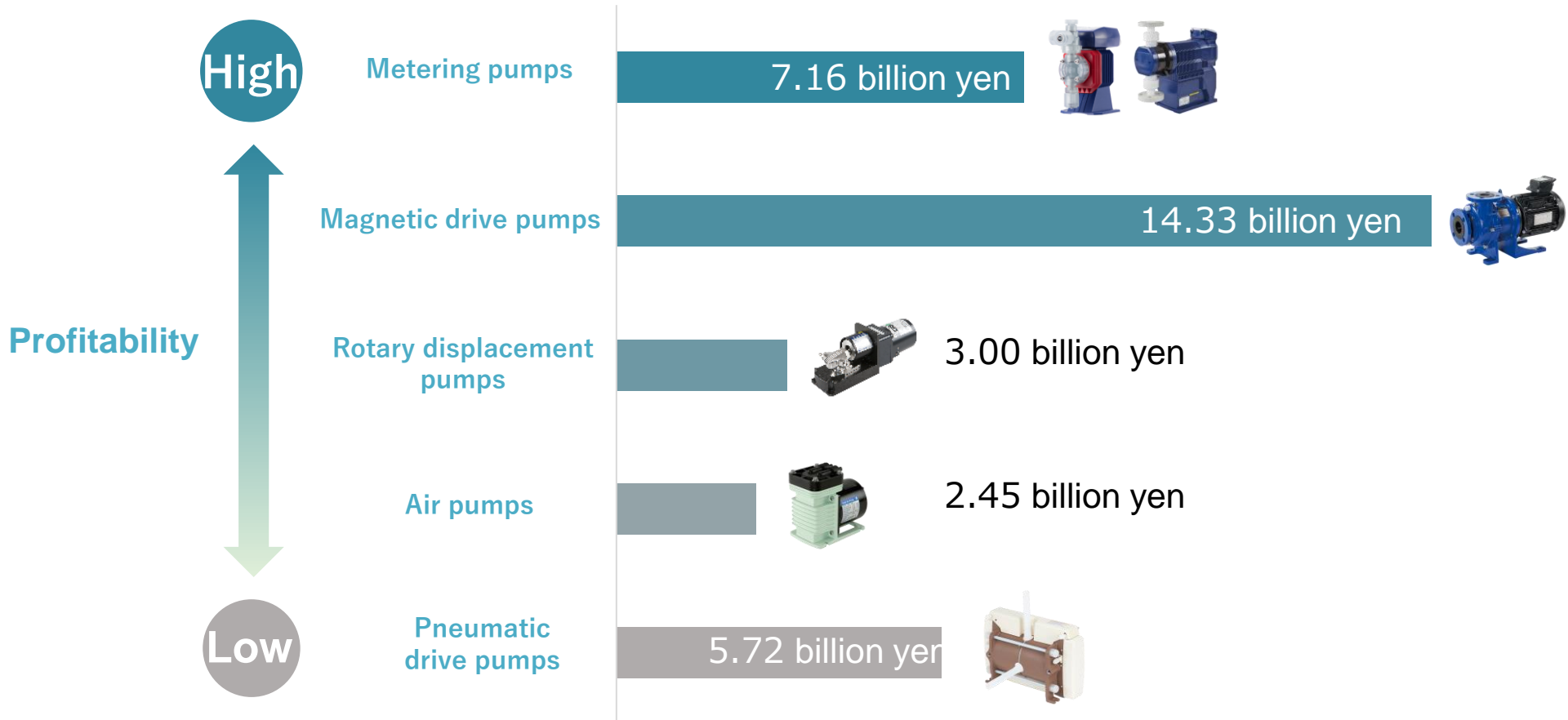

Annual capacity of around **800,000** units with the ability to produce many models in small quantities

Japan: Two plants with efficient small-lot production of many models and highly reliable quality assurance systems

Overseas: Five locations manufacture pumps using main parts exported from our plants in Japan (knock-down manufacturing), resulting in efficiency for deliveries and inventories

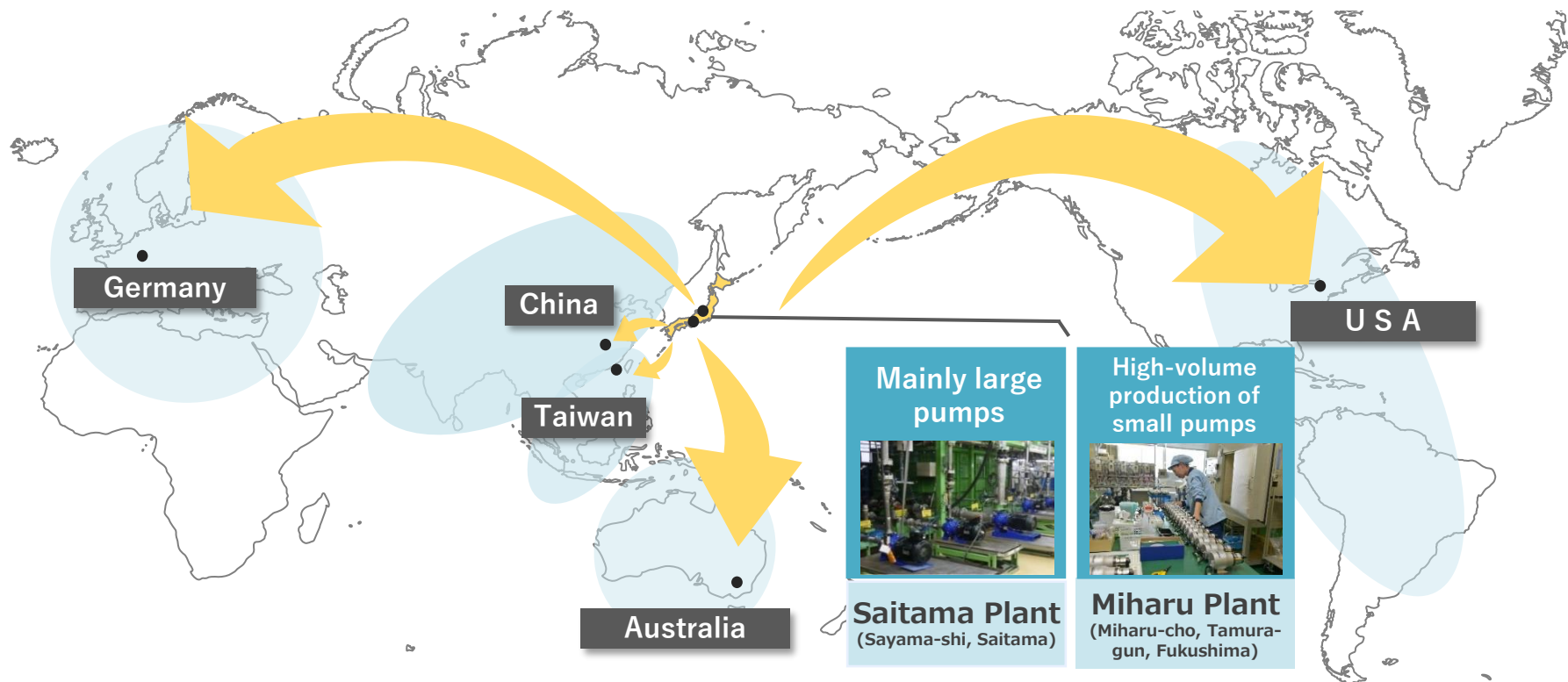

Branch offices and sales offices in 13 major cities Japan in addition to the head office

A worldwide sales and service network with 21 group companies in 15 countries

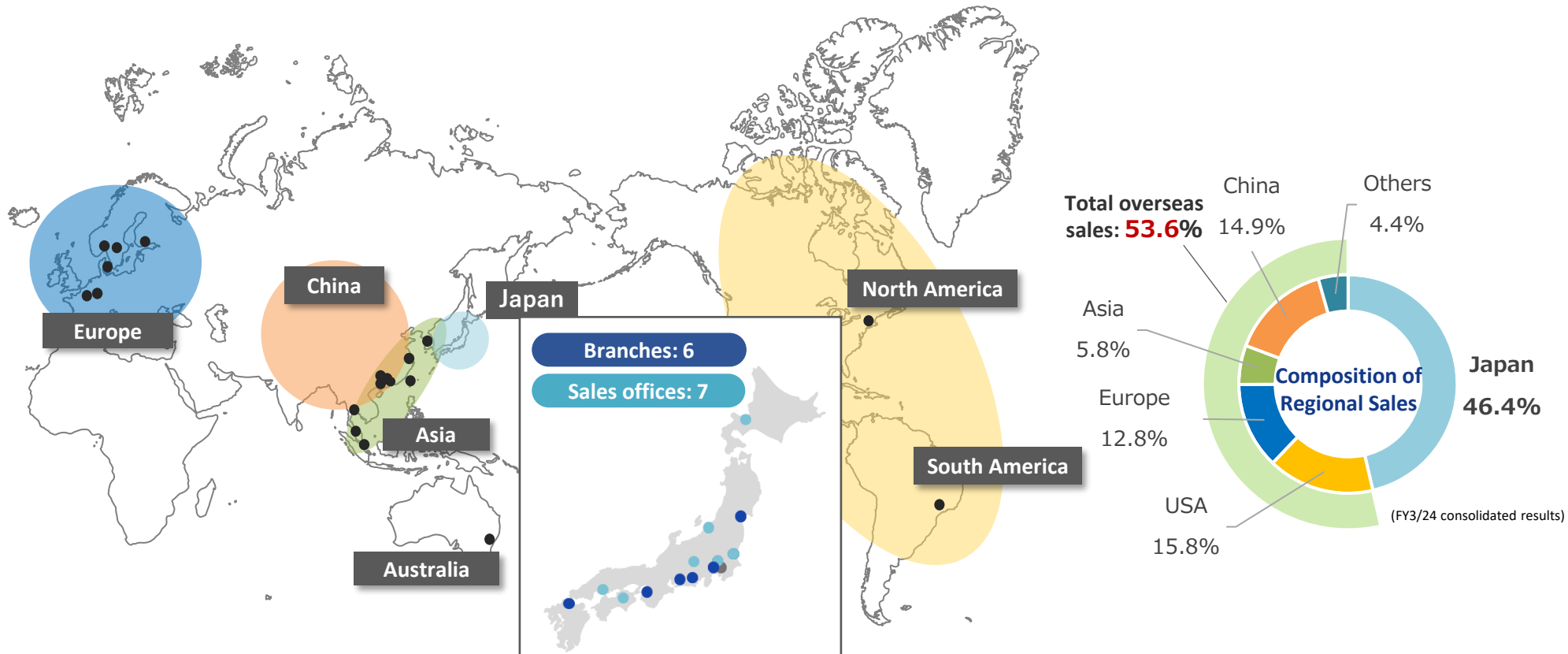

We provide **solutions** that meets customers' **needs**  
by providing pumps and leveraging our know-how of fluid control

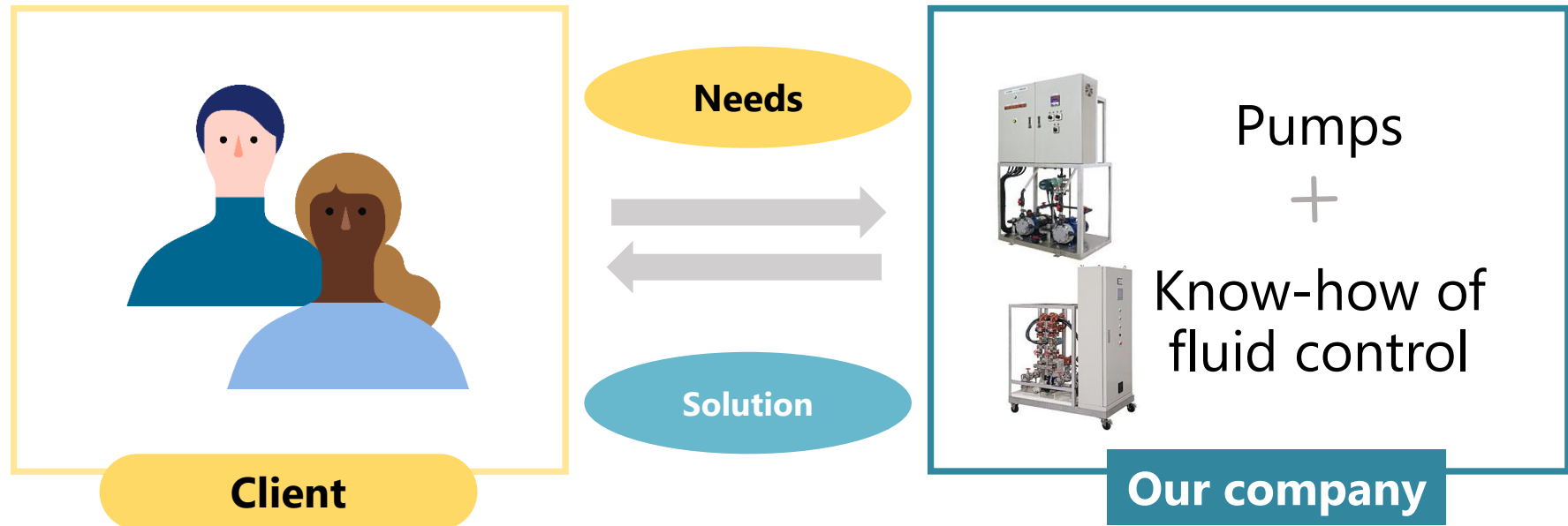

## Aquatic business

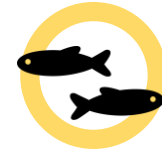

Experiments and research using mammals are difficult from an animal welfare perspective, and the maintenance and management costs of research mice and rats are high.

➔ **Aquatic organisms**, which have a similar DNA structure to mammals are beginning to attract attention

### Needs

- The research does not progress as planned due to incidental works such as water quality management or inspection / adjustment of various devices.
- No experience in treating aquatic lives.

I want to do cost effective research.



**Client**

### Solution

Pumps × Know-how of fish breeding

Developed **LABREED**

- water tank system for small fish



**Our company**

**III**

## **Our Strategies**

For more information on "10-Year Vision", please refer to the latest "Financial Results Briefing Materials".

Corporate Information Site : <https://www.iwakipumps.co.jp>

Please click on "The Vision of the Iwaki Group" on the top page of our Corporate Information Site for more details.

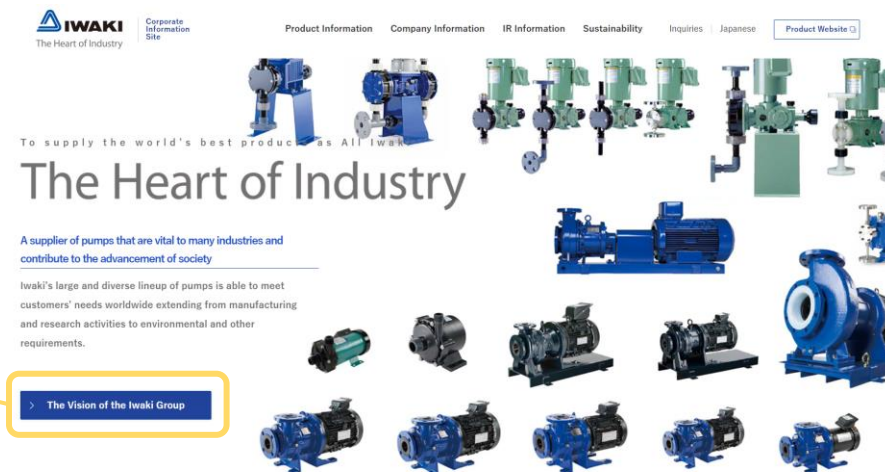

IR Information > Management Information > Business Strategies  
You can also find more details on this page.

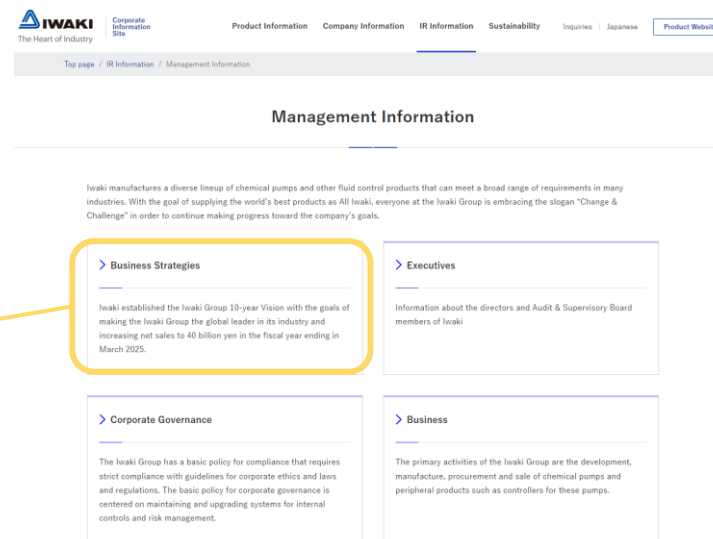
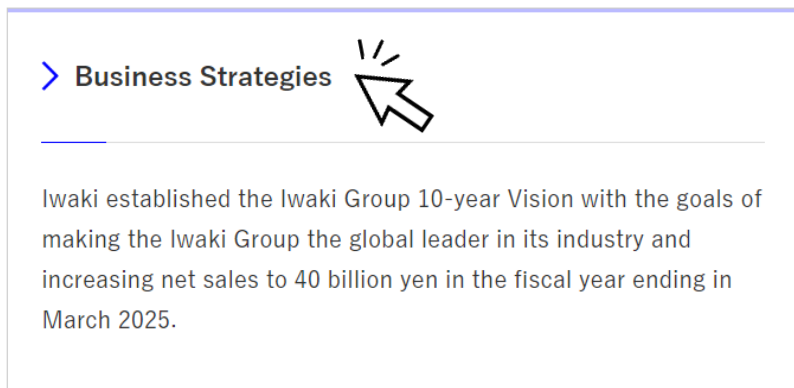

## Basic policy

Dividend payout ratio: more than 30%



Stable dividends

For more information on "Return to Shareholders", please refer to the latest "Financial Results Briefing Materials".

IR Information > IR Library > Financial Results Presentation Materials

For more information, please see this page on our website.

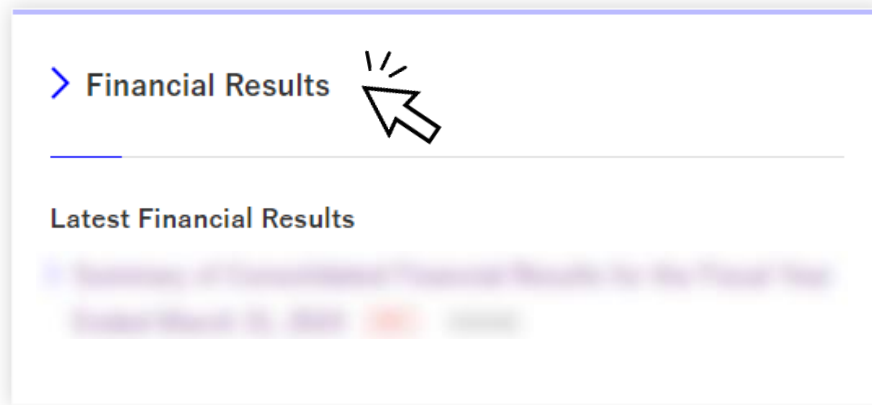
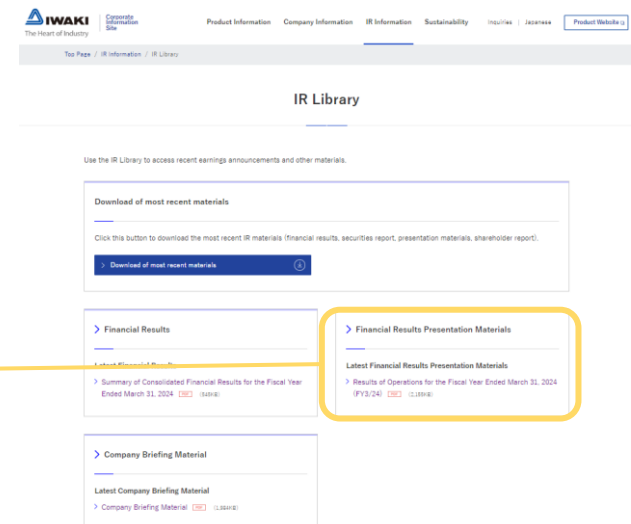





## The Heart of Industry

We will always be at the forefront of efforts to advance development in the global markets, industries and communities where we operate while building trust with, and contributing to the happiness of everyone we interact with.

