

# Iwaki

## Electromagnetic Metering Pump

---

### EHN-R

---

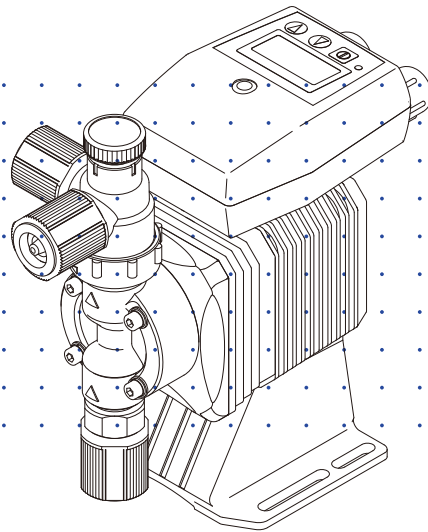

## Instruction manual

Thank you for choosing our product.



Please read through this instruction manual before use.

This instruction manual describes important precautions and instructions for the product. Always keep it on hand for quick reference.

## Order confirmation

Open the package and check that the product conforms to your order. If any problem or inconsistency is found, immediately contact your distributor.

### a. Check if the delivery is correct

Check the nameplate to see if the information such as model codes, discharge capacity and discharge pressure are as ordered.

Iwaki Metering Pump			
CAPACITY	ml/min	POWER CONSUMPTION	W
MAX.PRESSURE	MPa	THERMALLY PROTECTED	
STROKE RATE	spm	CURRENT	A
VOLTAGE	V	FREQUENCY	50/60 Hz
MODEL			
MFG.No.			
IWAKI CO.,LTD. MADE IN JAPAN			1P423609

OR

Iwaki Metering Pump			
CAPACITY	ml/min	MAX.PRESSURE	MPa
STROKE RATE	spm	VOLTAGE	V
FREQUENCY	50/60 Hz	POWER CONSUMPTION	W
THERMALLY PROTECTED		CURRENT	
MODEL		MFG.No.	
IWAKI CO.,LTD. TOKYO JAPAN			1P423609

### b. Check accessories are complete

- A check valve or a back pressure valve

\*The applicable check valve and back pressure valve vary with pump models. See page 108 for applicable pumps and specs.

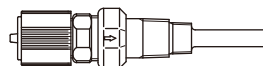

- Hose stoppers (ø4×ø6 or ø9×ø12)

\*The EHN-BN\_/\_-CN\_ PS½, EHN-BN\_/\_-CN\_ FC/SH and EHN-BN09 models have fixed-tube sizes. So any hose stopper is not additionally provided to that pump configuration.

\*Other pump configurations than above are equipped with the ø4×ø9 or ø8×ø13 hose stoppers when shipped from our factory. Use the additional ø4×ø6 or ø9×ø12 hose stoppers along with actual tube size to be used.



ø4×ø6 tubing



ø9×ø12 tubing

Model	EHN_MR	EHN_MKR	EHN_MR-NAE
# of hose stopper	4	3	5

Note one out of the additional hose stoppers are packed with the check valve in a plastic bag.

- A 3m PVC braided tube (ø4×ø9 or ø8×ø13)

\*Following tube is attached to:

- The EHN-BN\_/\_-CN\_ PP models: ø4×ø9 or ø8×ø13 EVA tube
- The EHN\_H (high pressure type): ø4×ø6 nylon tube

\*No tube is attached for the EHN-BN\_/\_-CN\_ FC/SH and EHN-BN09 models.

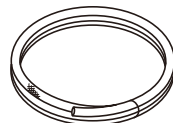

### c. Check if the delivery is damaged or deformed

Check for transit damage and loose bolts.

# Contents

Order confirmation .....	2
<b>Safety instructions .....</b>	<b>7</b>
WARNING .....	8
CAUTION .....	9
Precautions for use.....	11
<b>Overview.....</b>	<b>13</b>
<b>Introduction .....</b>	<b>13</b>
Pump structure & Operating principle .....	13
Features.....	14
<b>Operational functions.....</b>	<b>14</b>
Manual mode .....	14
EXT mode.....	15
■ Multiplier setting .....	15
■ Divisor setting .....	16
Control functions.....	17
■ STOP function.....	17
<b>Part names .....</b>	<b>18</b>
Pump.....	18
Operational panel .....	19
■ Basic displays & Pump states .....	20
<b>Identification codes .....</b>	<b>21</b>
Pump/Drive units .....	21
Control unit .....	23
<b>Installation .....</b>	<b>24</b>
<b>Pump mounting .....</b>	<b>24</b>
<b>Plumbing .....</b>	<b>25</b>
Tube connection .....	25
■ Multi-tube connection for the EHN-BN_/-CN_ VC/VS/PC/PS/PP models ...	26
■ Fixed-tube connection for the EHN-BN_/-CN_ FC and EHN-BN09 models..	27

Thread connection for the EHN-SH models.....	30
Check valve/Back pressure valve mounting.....	31
■ Tube connection for the EHN-BN_-/-CN_ VC/VS/PC/PS/PP/FC models .....	32
■ Thread connection for the EHN-BN_-/-CN_ SH models.....	33
<b>Wiring .....</b>	<b>36</b>
Power voltage/Earthing .....	36
Signal wire connection .....	38
<b>Operation.....</b>	<b>42</b>
<b>Before operation .....</b>	<b>42</b>
Points to be checked .....	42
Retightening of pump head fixing bolts .....	42
■ Use of hexagon wrench instead of a torque wrench.....	43
Degassing.....	43
■ EHN-BN_-/-CN_ MR and EHN-BN09VC models.....	44
■ EHN-BN_-/-CN_ MKR and EHN-BN_-/-CN_ FC models .....	45
■ EHN-BN_-/-CN_ SH models .....	47
Flow rate adjustment .....	49
■ Stroke rate adjustment .....	50
■ Stroke length adjustment .....	52
Before a long period of stoppage (one month or more).....	54
<b>Operation programming.....</b>	<b>55</b>
Programming flow.....	56
Manual operation .....	58
EXT operation.....	59
■ EXT mode .....	59
■ EXT mode setting .....	61
STOP function .....	70
■ STOP function setting .....	70
■ STOP function cancellation.....	72
Keypad lock .....	74
■ Keypad lock activation .....	75
■ Keypad lock release.....	75

**Maintenance..... 76**

**Troubleshooting ..... 77**

**Inspection ..... 79**

    Daily inspection .....79

    Periodic inspection .....79

**Wear part replacement ..... 80**

    Wear part list.....81

    Before replacement ..... 82

    Valve set replacement ..... 83

        ■ Discharge valve set disassembly/assembly..... 83

        ■ Suction valve set disassembly/assembly ..... 88

        ■ Auto vent valve set disassembly/assembly for the EHN\_NAE models ..... 89

    Diaphragm/Bolt gasket replacement .....91

**Exploded view ..... 94**

    Pump head, Drive unit & Control unit ..... 94

    Pump head ..... 95

        ■ EHN-BN\_/-CN\_ VC/VS/PC/PS M ..... 95

        ■ EHN-BN31/-CN31/-CN36 VC/VS MK ..... 96

        ■ EHN-BN\_/-CN\_ PP M .....97

        ■ EHN-BN11/-CN16 PS M-H..... 98

        ■ EHN-BN\_/-CN\_ FC ..... 99

        ■ EHN-BN\_/-CN\_ SH ..... 100

        ■ EHN-BN09VC ..... 101

        ■ EHN-CN31/-CN36 VS/PS MK-V ..... 102

        ■ EHN-BN\_/-CN\_ -NAE .....103

    Check valve (VC/VS/PC/PS/PP)..... 104

**Specifications/Outer dimensions.....105**

    Specifications .....105

        ■ Pump unit .....105

        ■ Control unit.....107

        ■ Power cable .....107

        ■ Pump colour .....107

■ Check valve.....	108
Outer dimensions.....	109
■ EHN-BN11/-BN16/-BN21 VC/VS/PC/PS/PP M .....	109
■ EHN-BN31 VC/VS/PC/PS/PP M.....	110
■ EHN-BN31 VC/VS MK.....	111
■ EHN-BN11/-BN21 FC.....	112
■ EHN-BN11/-BN21 SH .....	113
■ EHN-BN09VC .....	114
■ EHN-BN11/-BN16 VC/VS M-NAE.....	115
■ EHN-CN16/-CN21/-CN31/-CN36 VC/VS/PC/PS/PP M.....	116
■ EHN-CN31/-CN36 VC/VS MK .....	117
■ EHN-CN21/-CN31/-CN36 FC .....	118
■ EHN-CN21/-CN31/-CN36 SH .....	119
■ EHN-CN16/-CN21 VC/VS M-NAE.....	120

# Safety instructions

**Read through this section before use. This section describes important information for you to prevent personal injury or property damage.**

## ■ Symbols

In this instruction manual, the degree of risk caused by incorrect use is noted with the following symbols. Please pay attention to the information associated with the symbols.



### **WARNING**

Indicates mishandling could lead to a fatal or serious accident.



### **CAUTION**

Indicates mishandling could lead to personal injury or property damage.

A symbol accompanies each precaution, suggesting the use of "Caution", "Prohibited actions" or specific "Requirements".

#### Caution marks



Caution



Electrical shock

#### Prohibited mark



Prohibited



Do not rework or alter

#### Requirement mark



Requirement



Wear protection



Grounding



## **Export Restrictions**

Technical information contained in this instruction manual might be treated as controlled technology in your countries, due to agreements in international regime for export control.

Please be reminded that export license/permission could be required when this manual is provided, due to export control regulations of your country.

## WARNING

---

### Turn off power before service

Risk of electrical shock. Be sure to turn off power to stop the pump and related devices before service is performed.



---

### Stop operation

If you notice any abnormal or dangerous conditions, suspend operation immediately and inspect/solve problems.



---

### Do not use the pump in any condition other than its intended purpose

The use of the pump in any conditions other than those clearly specified may result in failure or injury. Use this product in specified conditions only.



---

### Do not modify the pump

Alterations to the pump carry a high degree of risk. It is not the manufacturer's responsibility for any failure or injury resulting from alterations to the pump.



---

### Wear protective clothing

Always wear protective clothing such as an eye protection, chemical resistant gloves, a mask and a face shield during disassembly, assembly or maintenance work. The specific solution will dictate the degree of protection. Refer to SDS precautions from the solution supplier.



---

### Do not damage the power cable

Do not pull, knot, or crush the power cable. Damage to the power cable could lead to a fire or electrical shock if cut or broken.



---

### Do not operate the pump in a flammable atmosphere

Do not place explosive or flammable material near the pump.



## ! CAUTION

### Qualified personnel only

The pump should be handled or operated by qualified personnel with a full understanding of the pump. Any person not familiar with the product should not take part in the operation or maintenance of the pump.



Requirement

### Use specified power only

Do not apply power other than that specified on the nameplate. Otherwise, failure or fire may result. Ensure the pump is properly grounded.



Prohibited

### Do not run pump dry

Do not run pump dry for more than 30 minutes (even when the pump runs for degassing). The pump head fixing screws may loosen and liquid may leak. Optimise your system. If the pump runs dry for a long period (for more than 30 minutes), the pump head and the valve guide may deform by friction heat and consequently leakage results.



Caution

### Keep electric parts and wiring dry

Risk of fire or electric shock. Install the pump where it can be kept dry.



Prohibited

### Ventilation

Fumes or vapours can be hazardous with certain solutions. Ensure proper ventilation at the operation site.



Caution

### Do not install /store the pump:

- In a flammable atmosphere or a dusty/humid environment.
- Where ambient temperature can exceed 0-40°C.
- In direct sunlight or wind & rain.



Prohibited

### Spill precautions

Ensure protection and containment of solution in the event of plumbing or pump damage (secondary containment).



Requirement

### Do not use the pump in a wet location

The pump is not waterproof. Use of the pump in wet or extremely humid locations could lead to electric shock or short circuit.



Prohibited

---

## Grounding

Risk of electrical shock! Always properly ground the pump. Conform to local electric codes.



---

## Install a GFCI (earth leakage breaker)

An electrical failure of the pump may adversely affect other devices on the same line. Purchase and install a GFCI (earth leakage breaker) separately.



---

## Preventative maintenance

Follow instructions in this manual for replacement of wear parts. Do not disassemble the pump beyond the extent of the instructions.



---

## Do not use a damaged pump

Use of a damaged pump could lead to an electric shock or death.



---

## Disposal of a used pump

Dispose of any used or damaged pump in accordance with local rules and regulations. If necessary, consult a licensed industrial waste disposal company.



---

## Check pump head bolts

Liquid may leak if any of the pump head bolts become loose. Tighten the bolts diagonally and evenly by the following torque before initial operation and at regular intervals.

### Tightening torque

EHN-BN09/-BN11/-BN16/-BN21, EHN-CN16/-CN21	: 2.16 N•m
EHN-BN31, EHN-CN31/-CN36	: 2.55 N•m



---

## Install a relief valve

Install a relief valve on a discharge line near the pump so as to automatically release the discharge pressure when it exceeds the maximum level.



---

## Use a proven chemically-resistant tube

The 3m PVC braided tube attached, for example, may be chemically attacked especially with sodium hypochlorite. Use a proven chemical resistant tube if an aggressive chemical is used.



## Precautions for use

- Electrical work should be performed by a qualified electrician. Otherwise, personal injury or property damage could result.



- Do not install the pump:
  - In a flammable atmosphere.
  - In a dusty/humid place.
  - In direct sunlight or wind & rain.
  - Where ambient temperature can exceed 0-40°C.
  - Where ambient humidity can exceed 85%RH.

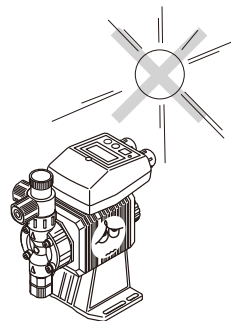

Protect the pump with a cover when installing it out of doors.

- Select a level location, free from vibration, that won't hold liquid. Anchor the pump with four M5 bolts so it doesn't vibrate. If the pump is not installed level, output may be affected.

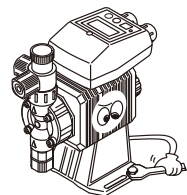

- When two or more pumps are installed together, vibration may be significant, resulting in poor performance or failure. Select a solid foundation (concrete) and fasten anchor bolts securely to prevent vibration during operation.



- Allow sufficient space around the pump for easy access and maintenance.



- Install the pump as close to the supply tank as possible.



- When handling liquids that generate gas bubbles (sodium hypochlorite or hydrazine solution), install the pump in a cool and dark place. Flooded suction installation is strongly recommended.



- Use care handling the pump. Do not drop. An impact may affect pump performance. Do not use a pump that has been damaged to avoid the risk of electrical damage or shock.

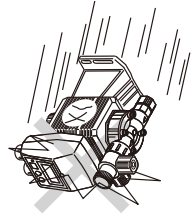

- The pump has a rating of IP66 equivalent, but is not waterproof. Do not operate the pump while wet with solution or water. Failure or injury may result. Immediately dry off the pump if it gets wet.



Caution

- Do not close discharge line during operation. Solution may leak or piping may break. Install a relief valve to ensure safety and prevent damaged plumbing.



Caution

- Do not use the control unit to a different drive unit of other pumps. An electrical circuit or the drive unit may fail.



Caution

- Solution in the discharge line may be under pressure. Release the pressure from the discharge line before disconnecting plumbing or disassembly of the pump to avoid solution spray.



Requirement

- Wear protective clothing when handling or working with pumps. Consult solution SDS for appropriate precautions. Do not come into contact with residual solution.



Caution

- Do not clean the pump or nameplate with a solvent such as benzene or thinner. This may discolor the pump or erase printing. Use a dry or damp cloth or a neutral detergent.



# Overview

**Pump characteristics, features and part names are described in this section.**

## Introduction

### Pump structure & Operating principle

The EHN series is a diaphragm metering pump which consists of a pump head, a drive unit, and a control unit. A diaphragm is directly driven by electromagnetic force.

#### Principle of operation

The pulse signal via the control unit generates the electromagnetic force to make reciprocating motion with the assistance of the spring force. The reciprocating motion is transferred to the diaphragm through the plunger and then volumetric change occurs in the pump head. This action transfers liquid along with pump head valve action.

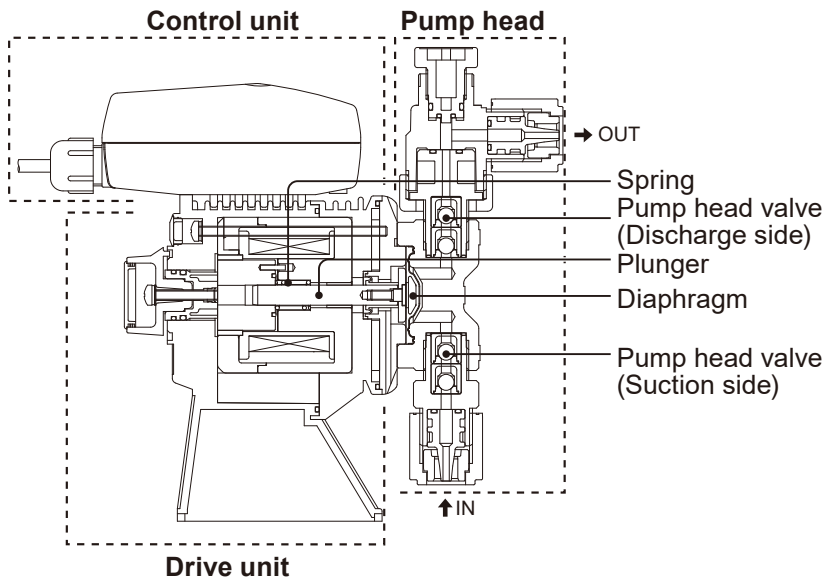

## Features

---

- **Multivoltage operation**

The EHN-R series is a multivoltage type (100-240VAC) and can be selected without local power limitations.

- **High turndown ratio**

A wide range, digitally-controlled, turndown ratio of 1-360spm (1-300spm for the EHN-VS-V and EHN-PS-V models) with fine flow tuning (stroke length adjustment)

- **Waterproof and dustproof structure**

The sealed unit design assures a rating of IP66 equivalent.

\*The pump is not waterproof. Protect the pump with a cover when installing it out of doors

- **Auto degassing system (Auto degassing type)**

Enables gaseous liquid delivery, expelling gas to open air to prevent gas lock in the pump head.

## Operational functions

### Manual mode

---

Run/stop the pump with the start/stop key. A stroke rate (MAN speed) can be changed in the range of 1-360spm (or 1-300spm for the EHN-VS-V and EHN-PS-V models) with the up and down keys at any time during operation or stop. See page 58 for detail.

\*The pump can also be turned ON/OFF by switching the main power.

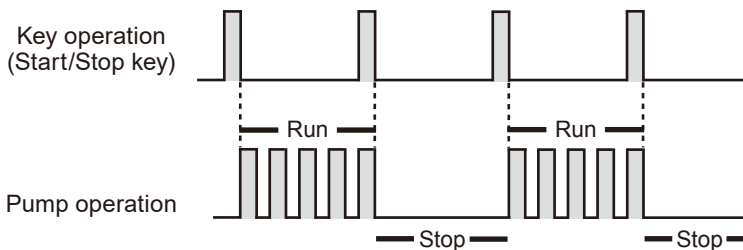

## EXT mode

### ■ Multiplier setting

The pump runs at the MAN speed for the preset multiplier (1-999 strokes) per incoming external signal. See page 62 as well.

\*The pump makes one stroke per pulse when the multiplier is set to 1.

\*The pump will pause operation while the STOP signal is input and resume operation when the STOP signal is released (if the pump is paused at the moment the first three strokes are completed, for example, the pump resumes to finish the remaining 4th and 5th strokes right after pausing is cancelled.).

\*Note the pump receives the pulse signal even when it is paused by the STOP signal.

Example) When the multiplier is set to 5, the pump makes five strokes per signal.

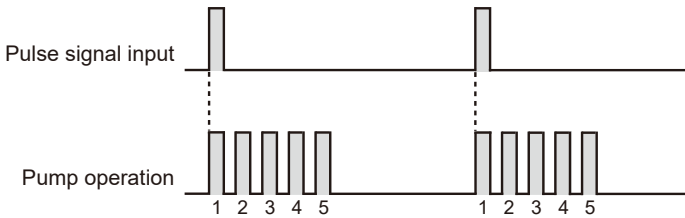

The buffer stores extra pulse signals which are entered before the scheduled strokes per signal are completed.

\*Extra pulses are stored for up to 64535 strokes.

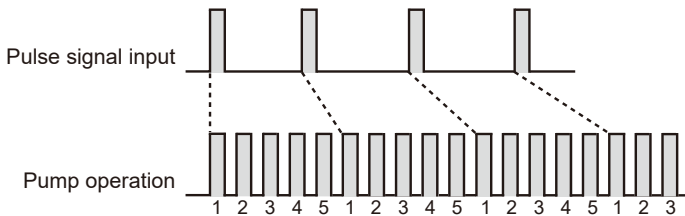

## ■ Divisor setting

The pump runs for the preset divisor (1-999 pulse rates) at every incoming external signals. See page 64 as well.

- \*The pump does not run over the MAN speed at any pulse rate. Excess pulse signals are cancelled.
- \*The pump makes one stroke per pulse when the divisor is set to 1.
- \*The pump will pause operation while the STOP signal is input and resume operation when the STOP signal is released (if the pump is paused at the moment the first three pulses are entered, for example, the pump resumes right after the remaining 4th and 5th pulses are entered.).
- \*The pump does NOT receive the pulse signal when it is paused by the STOP signal.

Example) When a divisor is set to 5, the pump makes one stroke every 5 signals.

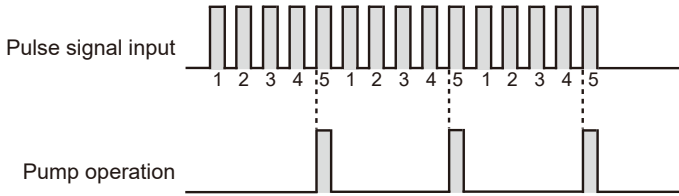

## Control functions

### ■ STOP function

The start/stop of the pump can be controlled by external devices such as a level sensor.

#### When "M-OFF" is selected:

The pump stops while receiving the external signal via the STOP terminal (closed circuit).

\*The pump resumes operation when the STOP signal is released.

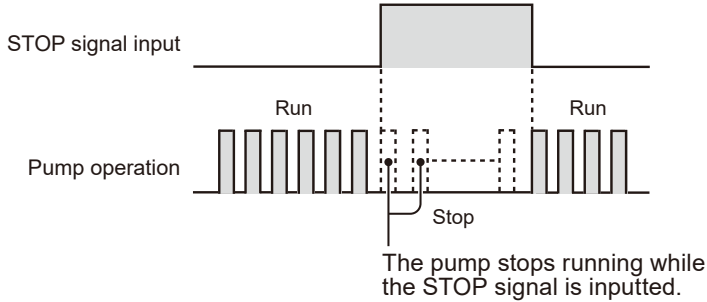

#### When "M-ON" is selected:

The pump runs while receiving the external signal via the STOP terminal (closed circuit).

\*The pump stops operation when the STOP signal is released.

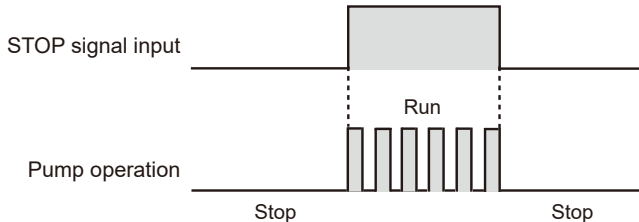

# Part names

## Pump

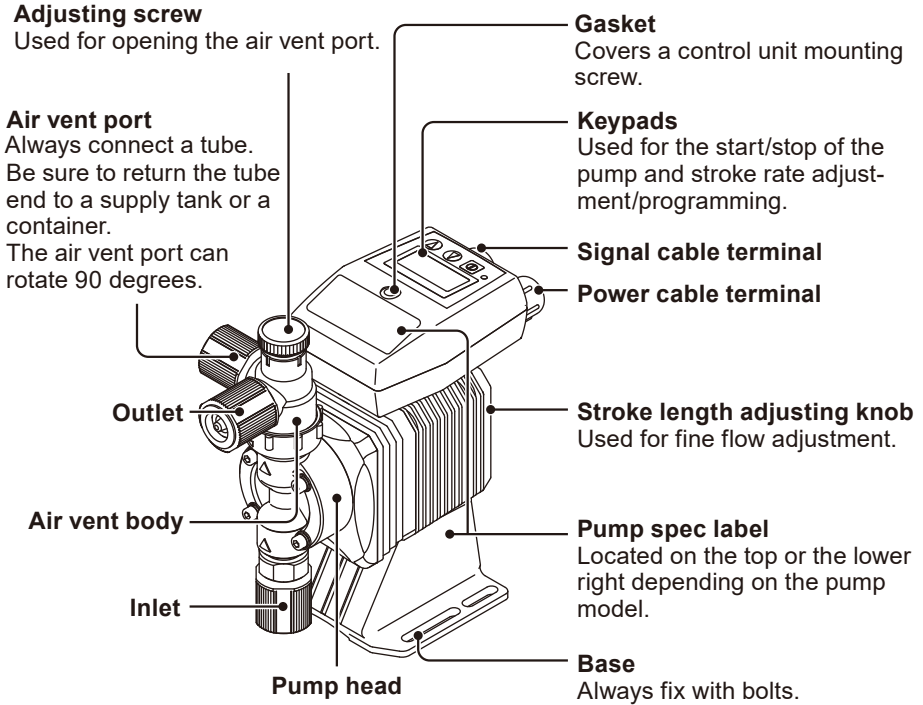

### Pump head

### AUTO degassing type (NAE)

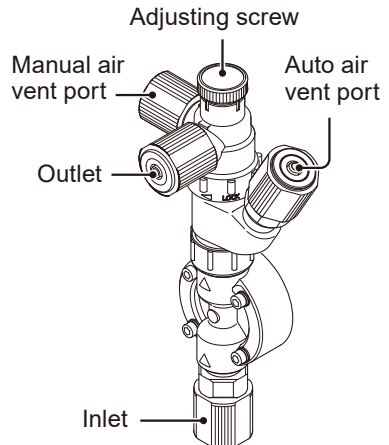
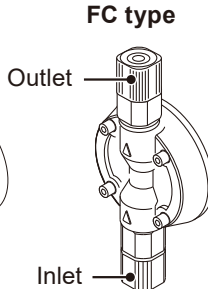
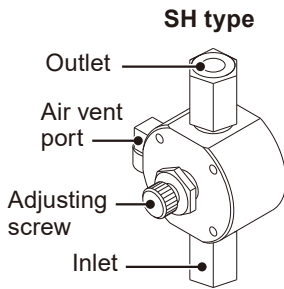

\*The FC type does not have an air vent port.

### Display

An operational status, a selected mode and a programmed value are shown here.

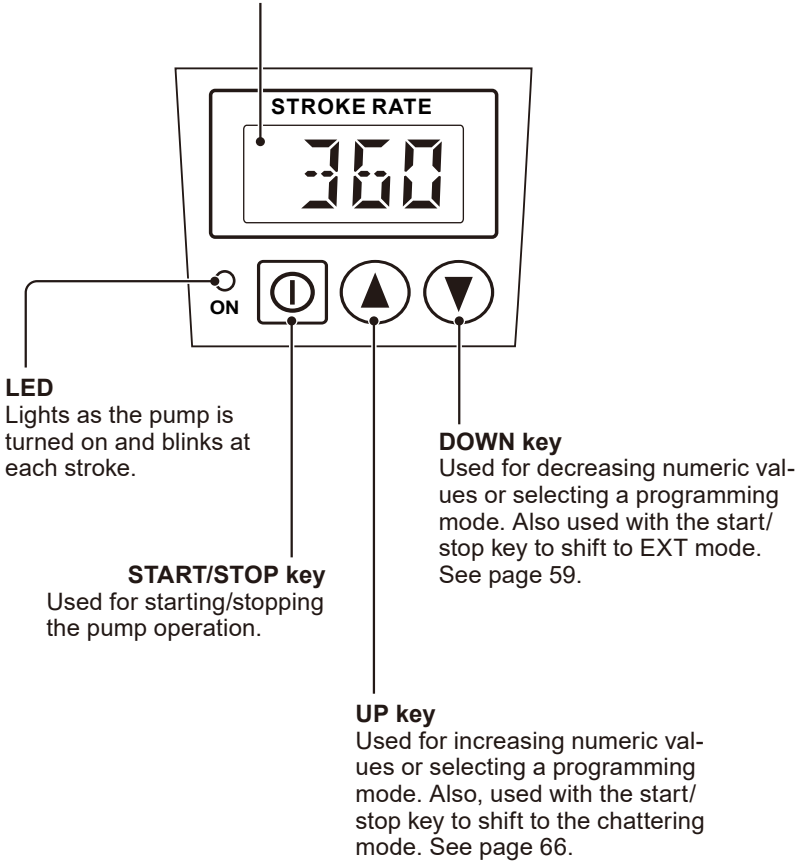

### LED

Lights as the pump is turned on and blinks at each stroke.

### START/STOP key

Used for starting/stopping the pump operation.

### DOWN key

Used for decreasing numeric values or selecting a programming mode. Also used with the start/stop key to shift to EXT mode. See page 59.

### UP key

Used for increasing numeric values or selecting a programming mode. Also, used with the start/stop key to shift to the chattering mode. See page 66.

## ■ Basic displays & Pump states

	LED lights	LED blinks
	A wait state in MAN mode. The screen shows the MAN speed (spm).	Operation in MAN mode. A current spm flashes. The screen shows MAN speed.
	A wait state in EXT mode (E-EX), waiting for the external signal.	Operation in EXT mode (E-EX) with the external signal.
	A wait state in EXT mode (E-SP), waiting for the external signal. The screen shows ".0".	Operation in EXT mode (E-SP), with the external signal. The screen shows MAN speed.
	STOP signal is entered to the pump to suspend its operation.	—
	STOP signal is entered to the pump while the pump is in a wait state and the mode is MAN.	—
	Anti-chattering values. T-5, T-10, and T-50 represent the approximate time (msec) to read the external pulse signal.	—
	EXT mode with a preset divisor	—
	EXT mode with a preset multiplier	—
	A divisor is set for EXT mode. "5" represents the pump makes one stroke at every five(5) signals.	—
	A multiplier is set for EXT mode. "X5" represents the pump makes five(5) strokes per signal.	—
	The pump behaviour with the STOP signal is selected.	—
	—	The number of external signals has exceeded the upper limit spm (MAN speed) in EXT mode. The pump does not run over the MAN speed.
	Keypad is locked. Any key operation is ineffective. See page 75 to release this state.	Keypad is locked. Any key operation is ineffective. See page 75 to release this state.

## Identification codes

The model codes of the pump/drive units and the control unit represent the following information.

### Pump/Drive units

#### **EHN - BN 11 VC \_ M K R - \_**

**a      b      c      d      e      f      g      h      i**

#### a. Series name

EHN: Multivoltage electromagnetic metering pump

#### b. Drive unit (average power consumption)

BN: 20W

CN: 24W

#### c. Diaphragm effective diameter

09: 8mm      11: 10mm      16: 15mm

21: 20mm      31: 30mm      36: 35mm

#### d. Wet end materials

Pump

Code	Pump head	Fitting	Valve	O ring	Valve seat	Gasket	Diaphragm
VC	PVC	PVC	Alumina ceramic	FKM	FKM	PTFE	PTFE (bonded to EPDM)
VS			SUS316 equivalent	EPDM	EPDM		
PC	GFRPP	GFRPP	Alumina ceramic	FKM	FKM		
PS			SUS316 equivalent	EPDM	EPDM		
PP			Alumina ceramic	FKM	PCTFE		
FC	PVDF	PVDF		-	SUS316		
SH	SUS316	SUS316	HC				

\*The wet end materials of the EHN-BN09VC pump uses:

- The acrylic pump head, and
- The PTFE diaphragm seat plus the titanium diaphragm stopper.

Automatic air vent (Auto degassing type)

Code	Air vent valve guide A	Air vent valve guide B	Valve	Separate pin	Valve seat	O ring
VC	PVC	PVC	Zirconia ceramic	Titanium	FKM	FKM
VS			SUS316	SUS316	EPDM	EPDM

**Material code**

PVC : Polyvinyl chloride

GFRPP : Glassfiber-reinforced polypropylene

EPDM : Ethylene-propylene rubber

FKM : Fluorine-contained rubber

PTFE : Polytetrafluoroethylene

PCTFE : Polychlorotrifluoroethylene

HC : Hastelloy C276 equivalent

SUS316 : Austenitic stainless steel

PVDF : Polyvinylidene difluoride

**e. Connection**

Code	Tube I.D. × O.D.
No code	ø4×ø9 / ø4×ø6*
	ø8×ø13 / ø9×ø12*
1	ø4×ø9
2	ø4×ø6
6	ø10×ø12
9	Rc1/4" female thread
1/2	IN: ø4×ø9 OUT/AIR: ø4×ø6

\*When the ø4×ø6 or ø9×ø12 tube is used, use the attached hose stopper accordingly.

**f. Fitting**

No code: Fixed-tube connection

M: Multi-tube connection

**g. Air vent valve**

No code: Pumps with air vent port

K: No air vent port

**h. Control unit function**

R: Standard

**i. Special version**

No code: Standard

01-99: Customized wet ends and tube sizes

55: High compression type

H: High pressure type

V: High viscosity type

NAE: Auto degassing type

### **EHNC - B R -** **a        b c     d**

#### **a. Model**

EHNC: Multivoltage control unit

#### **b. Drive unit**

B: 20W

C: 24W

#### **c. Control unit function**

R: Standard

#### **d. Special version**

No code: Standard

01-99: Customized model

V: High viscosity type

# Installation

***This section describes the installation of the pump, tubing and wiring. Read through this section before work.***

**!** Observe the following points when installing the pump.

- Risk of electrical shock. Be sure to turn off power to stop the pump and related devices before service is performed.
- If you notice any abnormal or dangerous conditions, suspend operation immediately and inspect/solve problems.
- Do not place explosive or flammable material near the pump.
- Do not use a damaged pump. Use of a damaged pump could lead to an electric shock or death.

## Pump mounting

*Select an installation location and mount the pump.*

### Necessary tools

- Four M5 bolts (pump mounting)
- An adjustable wrench or a spanner

### 1 Select a suitable place

Select a level location, free from vibration, that won't hold liquid. See page 11 for detail. Flooded suction installation is strongly recommended when handling liquids that generate gas bubbles (sodium hypochlorite or hydrazine solution) or slurry liquid.

### 2 Anchor the pump with the M5 bolts

Be sure to fix the pump at four points.

#### NOTE

If the pump is not installed level, output may be affected.

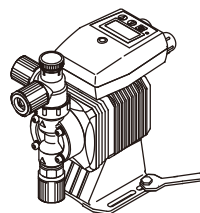

## Plumbing

Connect tubes to the pump and install a check valve.

### Before operation

- Cut the tube ends flat.

Tube end  
(side view)

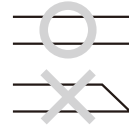

### Necessary tools

- An adjustable wrench or a spanner

## Tube connection

### When the tube is removed and then reconnected

- If the fitting nut, stopper, adaptor, fitting, or tube surface is wet with a chemical liquid, flush with tap water and then dry off. Wet parts won't bite into the tube successfully, and the tube may slip out of the connection with a chemical spill.
- When removing the connection, if the adaptor has become stuck in the crushed tube and stopper and those parts can not be separated, contact us for a new adaptor/stopper set.
- Do not reuse the same crushed tube end to reseal the tubing. Cut off the end and start with new tubing to ensure a new seal is established.
- Use a new tube if the old tube is hardened, swollen, discoloured, cracked, worn, or sticky.

## ■ Multi-tube connection for the EHN-BN\_/\_-CN\_ VC/VS/PC/PS/PP models

### When the tube is first connected

- a. Pass the tube through the fitting nut and stopper, and then slide it down onto the adaptor to the following depth or farther.

Tube size (I.D.×O.D.)	Depth (A)
ø4×ø6	6mm
ø4×ø6 (High Press)	1mm
ø4×ø9	4mm
ø9×ø12	7mm
ø8×ø13	5mm

\*If you are to use a ø4×ø6 or ø9×ø12 tube size, change the hose stopper accordingly.

\*See the back side of the stopper for the stopper size (tube O.D.).

\*The shapes of the hose stoppers differ according to the size.

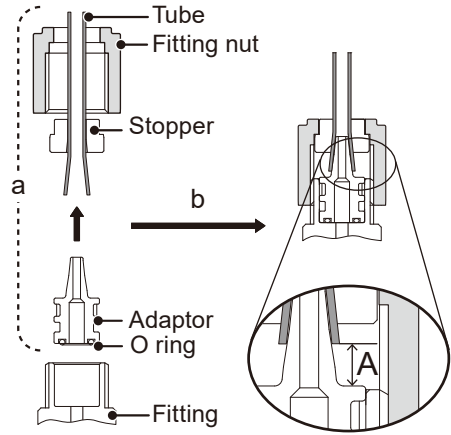

Stopper size  
(Tube O.D.)

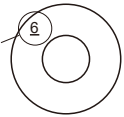

6 size hose stopper  
for ø4×ø6 tube



9 size hose stopper  
for ø4×ø9 tube



12 size hose stopper  
for ø9×ø12 tube



13 size hose stopper  
for ø8×ø13 tube

Mount its bottom to hose adaptor

No mounting direction

- b. Put the tube end (adaptor) onto the fitting. Then hand tighten the fitting nut.

\*Make sure the O ring is in place (beneath the adaptor), or leakage of the solution may result.

- c. Retighten the fitting nut by turning it further 180 degrees with an adjustable wrench or a 27mm spanner so it crushes into the tube a little.

\*Do not use excessive force when tightening the plastic fitting nut. Overtightening may crush tube too thin and weaken connection.

\*Some tubing may be too firm to be pushed onto the adaptor to the designated depth shown above. If so, wet the tapered area of the adaptor to give it some lubricity, or immerse the tube end into warm water (40°C or below) to give it more flexibility.

■ Fixed-tube connection for the EHN-BN\_/-CN\_ FC and EHN-BN09 models

**When the tube is first connected**

- a. Pass the tube through the fitting nut and slide it down onto the fitting to the following depth or farther.

Tube size (I.D.×O.D.)	Depth (A)
ø4×ø6	1mm
ø4×ø9	4mm
ø10×ø12	1mm

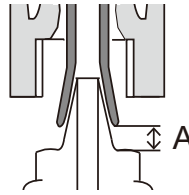

- b. Then hand tighten the fitting nut.

- c. Retighten the fitting nut by turning it 180 degrees with an adjustable wrench or a following spanner.

Model	Spanner size
EHN-BN/-CN 11/21 FC	22mm
EHN-BN/-CN 31/36 FC	24mm
EHN-BN09	22mm

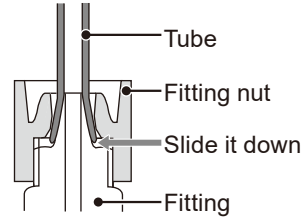

\*Do not use excessive force when tightening the plastic fitting nut. Overtightening may crush tube too thin and weaken connection.

\*Some tubing may be too firm to be pushed onto the fitting to the designated depth shown above. If so, wet the tapered area of the fitting to give it some lubricity, or immerse the tube end into warm water (40°C or below) to give it more flexibility.

**1 Connect tubes into the pump inlet and outlet**

**Multi-tube connection**

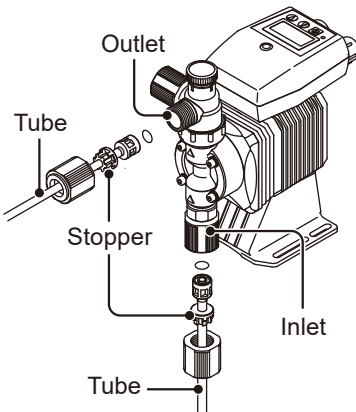

**Fixed-tube connection**

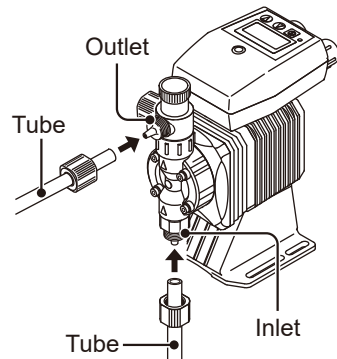

## 2 Connect a tube to establish the air vent line

Route back the other tube end to a supply tank or a container.

### Multi-tube connection

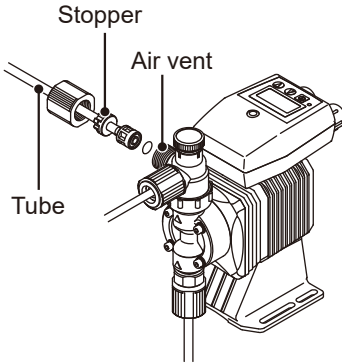

### Fixed-tube connection

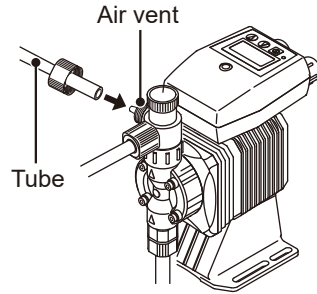

## 3 For the NAE type, connect an air bleed tube to establish the AUTO air vent line

Route back the other tube end to a supply tank or a container.

Even after gas is eliminated from the pump, a small amount of liquid is continuously expelled through the air vent path as long as the pump is running (you will see more liquid in siphoning).

\*If you are to use a  $\varnothing 4 \times \varnothing 6$  tube, change the stopper size accordingly.

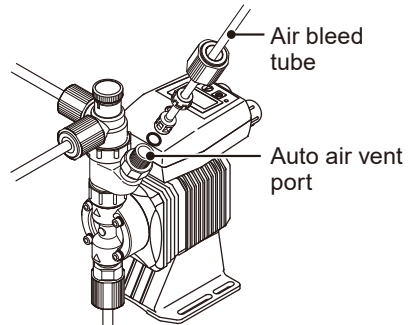

NAE type

## 4 Determine the air vent body A direction

The air vent body A can rotate 90 degrees.

- Loosen the lock nut.
- Turn the air vent body A to the optimal direction.
- Hand-tighten the lock nut, holding the air vent body A.
- Use an adjustable wrench or a following spanner to turn the lock nut further 90 degrees.

Model	Spanner size
EHN_MR	38 mm
EHN-BN09	32 mm

### Multi-tube connection

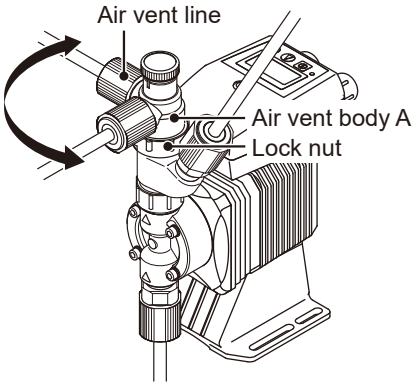

### Fixed-tube connection

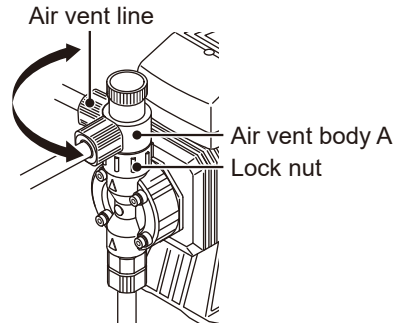

## 5 For the NAE type, determine the AUTO air vent port direction

The fitting adaptor can rotate 90 degrees.

- Loosen the lower lock nut.
- Turn the fitting adaptor to the optimal direction.
- Hand-tighten the lower lock nut, holding the fitting adaptor.
- Use an adjustable wrench or a 32mm spanner to turn the lock nut further 90 degrees.

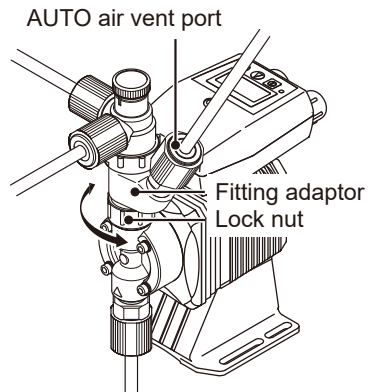

## NOTE

The air vent port is not provided to the EHN-BN\_-/-CN\_MKR and EHN-BN\_-/-CN\_FC models. Install an air vent valve as the right diagram shows.

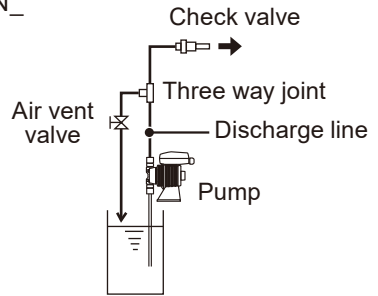

## Thread connection for the EHN-SH models

- 1** Wrap a sealing tape around the threads of the air vent port and screw it into the pump head

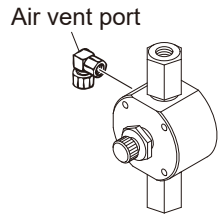

- 2** Connect pipes into the pump inlet and outlet (Rc $\frac{1}{4}$  female thread)

Use a proper pipe size to prevent a leakage or entrained air.

\*Establish the shortest pipe line length and the minimum number of bends so the pipe resistance is minimized.

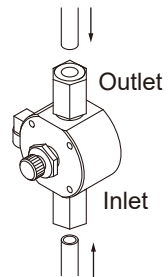

- 3** Connect a pipe to establish the air vent line

Route back the other tube end to a supply tank or a container.

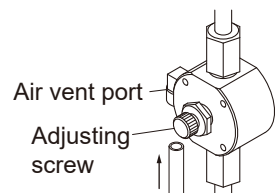

## NOTE

Even if the adjusting screw of the EHN-BN\_/-CN\_SH models are loosened, the discharge line may be under pressure. Install an air vent valve on the discharge line as well.

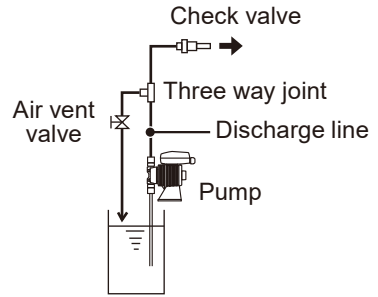

## ***Check valve/Back pressure valve mounting***

*Install a provided check valve or a back pressure valve to the pump for the prevention of a back flow, siphon and overfeeding. In the following cases, be sure to install the check valve or a back pressure valve.*

- A suction side liquid level is higher than a discharge side or an injection point at atmospheric pressure.

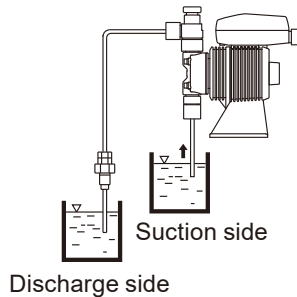

- A discharge side liquid level is higher than a suction side but the distance is 5m or below.

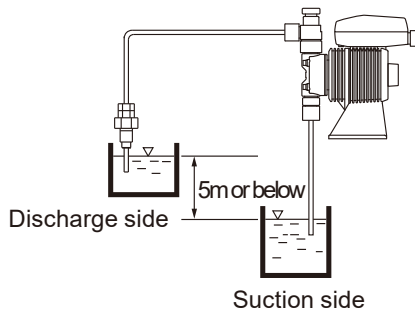

- A suction line pressure is higher than a discharge line pressure.

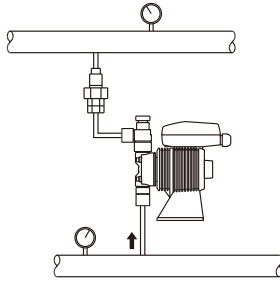

- A discharge pressure (including pipe resistance and discharge head) is below 0.13MPa (below 0.049MPa for the EHN-BN31/-CN36 models).

### ■ Tube connection for the EHN-BN\_/-CN\_ VC/VS/PC/PS/PP/FC models

#### 1 Mount a check valve or a back pressure valve at the discharge tube end

\*The CAN check valve has the R $\frac{1}{2}$ " and R $\frac{3}{8}$ " thread connections as well as an O.D.9mm tube connection. The BVC back pressure valve has the R $\frac{1}{2}$ " and R $\frac{3}{8}$ " thread connections as well as an O.D.12mm tube connection. If required, trim off an amount of the extension tip until it fits your fitting or tee.

\*If you are to use a different tube size ( $\varnothing 4 \times \varnothing 6$  or  $\varnothing 9 \times \varnothing 12$ ) with a multi-tube connection, change stopper size accordingly.

#### NOTE

The maximum allowable tightening torque of the R $\frac{1}{2}$ " and R $\frac{3}{8}$ " thread connections are 10 N·m. Do not use excessive force when tightening into a pipe.

#### CAN check valve

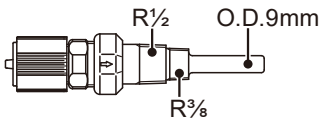

#### BVC back pressure valve

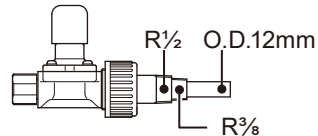

\*The CBN check valve (both ends tube connections) is optionally available. Contact us or your nearest distributor.

#### CBN check valve



## ■ Thread connection for the EHN-BN\_-/CN\_ SH models

### 1 Mount a check valve at the discharge pipe end

The discharge line must be 1 m or longer.

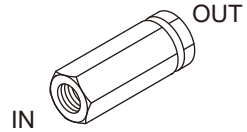

### NOTE

- Periodically clean or replace a check valve with new one for the prevention of crystal clogging, especially when using sodium hypochlorite.
- If the set pressure of the check valve plus the injection point pressure to your system is lower than the maximum discharge pressure of the pump, the pump output can exceed the specified point. See page 49 and adjust the output capacity.

### ■ Tubing layout

#### Flooded suction application

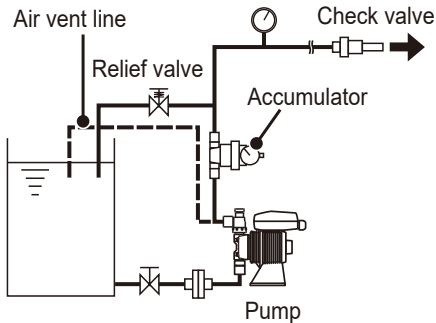

#### Suction lift application

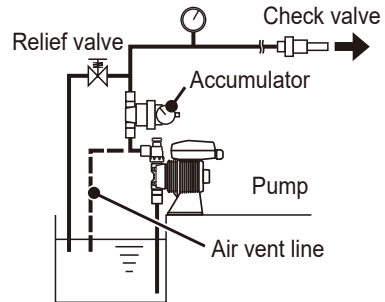

### ■ Tubing layout of the EHN\_NAE models

#### Flooded suction application

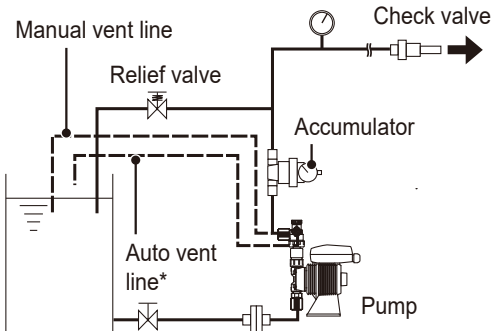

#### Suction lift application

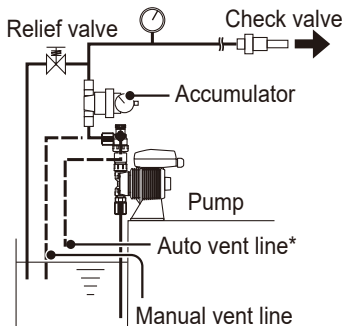

## NOTE

---

- \*Flooded suction installation is strongly recommended when handling liquids that generate gas bubbles (sodium hypochlorite or hydrazine solution).
  - \*The EHN VS-V/PS-V models require use of a flooded suction installation.
  - \*Install a branched pipe and a relief valve on the discharge line for the prevention of excessive pressure that might be caused by a clogged injection point.
  - \*When flooded suction installation is established, keep the suction line length shorter than 1m for ensuring the auto degassing system works properly. Any longer length may contain too much gas inside which exceeds the degassing capability of the pump, however, use of an optional Iwaki DG degassing joint to the pump inlet can help enhance the degassing capability.
  - \*When the pump and system are restarted after a long interval, be sure to expel gas from the pump and the suction line manually through the degassing step on page 43.
  - \*Even after gas is eliminated from the pump, a small amount of liquid is continuously expelled through the air vent path as long as the pump is running (you will see more liquid in siphoning). Be sure to route back the end of the auto air vent line to a supply tank or a container.
  - \*The auto air vent line to a supply tank or a container must be established in the possible shortest distance without any arched line.
  - \*Keep the auto vent line open ended to atmosphere. Do not immerse the tube end in solution in a supply tank.
- 

### **When the BVC back pressure valve is used:**

- Mount the BVC valve on the vertical discharge line ensuring the BVC outlet directs upwards.
  - \*If you mount the BVC valve in a horizontal discharge line or upside down, it does not work properly.
- If plumbing is extended further beyond the mounting location of the BVC valve, do not install a shut-off valve on the extended line. This product will be damaged if the shut-off valve is fully closed while the pump is running.
- If plumbing is extended further beyond the mounting location of the BVC valve, always keep the pressure in the extended plumbing half or lower than the set pressure of the BVC valve.
- Replace gaskets with new ones every time when the nut is loosened or the BVC valve is taken apart. Fasten the nut by 9.0N•m after putting them together so the gasket is crushed properly to ensure the new sealing.
  - \*If gaskets are reused or if the nut is not tightened by the rated torque, the sealing may be imperfect.

## ■ BVC pressure setting

The set pressure of the BVC valve is adjusted with tap water and then shipped from our factory. If you need to adjust the set pressure according to your environment, follow the steps as shown below.

### 1 Open the cap and loosen the M5 hexagon lock nut

### 2 Turn the pressure adjusting bolt to the set pressure

Always check the pressure gauge while it is adjusted.

#### NOTE

The pressure increases as the adjusting bolt is tightened clockwise and decreases as loosened. Rotate the bolt clockwise by two to three turns to raise pressure and then start to reduce pressure to a specified level.

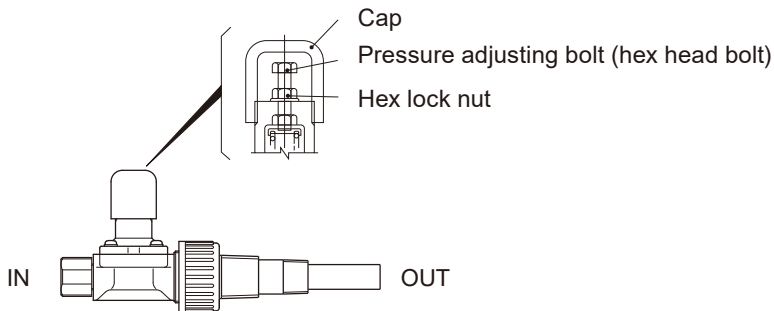

### 3 Fasten the hexagon lock nut to "lock" the pressure adjusting bolt

Get the cap back afterwards.

## Wiring

*Wiring for a power voltage, earthing and an external signal.*

### **!** Observe the following points during wiring work.

- Electrical work should be performed by a qualified electrician. Always observe local electric codes.
- Observe the rated voltage range, or the electrical circuit in the control unit may fail.
- Do not perform wiring work while electric power is ON. Otherwise, an electrical shock or a short circuit may result. Be sure to turn off the power before wiring work.
- Be careful for electric power NOT to be turned on during work.

### Necessary tools

- An adjustable wrench or a 20mm spanner
- A Phillips screw driver
- A precision screw driver

## **Power voltage/Earthing**

Check that the main power is turned off.

### **1** Connect power cable via crimp contacts

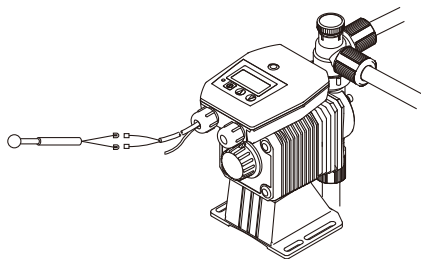

### **2** Earth the pump

## NOTE

- Do not share a power source with a high power device which may generate a surge voltage. Otherwise an electronic circuit may fail. The conductive noise caused by an inverter also affects the circuit.
- Energize the pump with a power voltage via a mechanical relay or switch. Do not fluctuate the voltage, or CPU may malfunction. See the next page for the precautions for ON-OFF control by cycling power.

### Apply power sharply

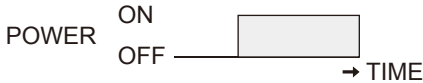

### Do not apply gradually



- Use a circuit protector (250VAC, 3A Medium speed) as necessary.
- Do not use a motor thermal relay.

## Surge voltage

The electronic circuit in the control unit may fail due to surge voltage. Do not place the pump close to a high power device of 200V or more which may generate a large surge voltage. Otherwise, take any of the following measures.

- Install a surge absorption element (ex. a varistor with capacity of 2000A or more) via power cable.

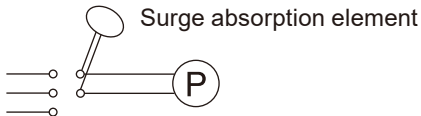

Recommended varistors:

Panasonic ERZV14D431

See manufacturer's catalogues for detail.

- Install a noise cut transformer via power cable.

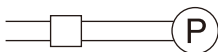

Noise cut transformer

### **Precautions for ON-OFF control by cycling power**

The control unit is equipped with a CPU. To ensure the CPU to work properly, always start/stop the pump with the STOP signal for ON-OFF control. Try not to turn on and off the main power. Otherwise, observe the following points:

- Ensure the minimum OFF time of 10 minutes.
- When using a mechanical relay for ON-OFF operation, its contact capacity should be 5A or more. Or a contact point may break.
- If a mechanical relay with the contact capacity of 5A is used, the maximum allowable number of power cycles is limited to 150,000 times. Use the contact capacity of 10A or more when the power cycles exceed that number or when a power source is shared with a large capacity equipment which may cause a surge voltage and damage a contact point.
- Even the large mechanical relay may not last forever. If further longer life is desirable, use a SSR (Solid State Relay) such as the OMRON G3F that does not have a mechanical contact point. Note this product is not designed to be operated with a zero-crossing SSR. See manufacturer's catalogs and make sure a non zero-crossing SSR is selected.

## ***Signal wire connection***

---

### **Points to be checked**

- Check that the main power is turned off.  
The pump is still charged right after turning off power. Wait for one minute before wiring is performed.

### **Applicable cables**

Cable outer diameter: 7.6-7.8mm

Cable type: 3-conductor cable: VCTF-3 1.25mm<sup>2</sup>

2-conductor cable: UL, CSA SJT 18AWG/2

\*A cable with the larger O.D. than 7.8mm can not be fitted to the controller. A smaller O.D. cable than 7.6mm may impair water-/dust-tightness of the controller.

## NOTE

- Do not lay on these signal cables in parallel with a power cable. Otherwise the electromagnetic induction noise is generated and malfunction or failure may result.
- When using an external SSR for signal input, such a semiconductor relay must be capable of handling the maximum applied voltage from the pump (12V with 5mA). Also, its leak current must be 0.1mA or below.

See specs of the selected SSR. The OMRON G3TA-IDZR02S-US SSR or the G3TA-IDZR02SM-US SSR at least meets the requirement.

- When using an external mechanical relay for signal input, such a relay must be capable of handling the maximum applied voltage from the pump (12V with 5mA).

\*Use either an external no-voltage contact or an external open collector for the signal line wiring.

\*Set pulse duration to 10-100ms and the number of pulses at or below 360 pulses per minute (300 pulses for the EHN VS-V/PS-V models).

## 1 Demount the control unit

- Remove the rubber cap, fixing screw and gasket from the top of the unit.
- Loosen the two tapping screws (A) located above the stroke length adjusting knob and detach the control unit.

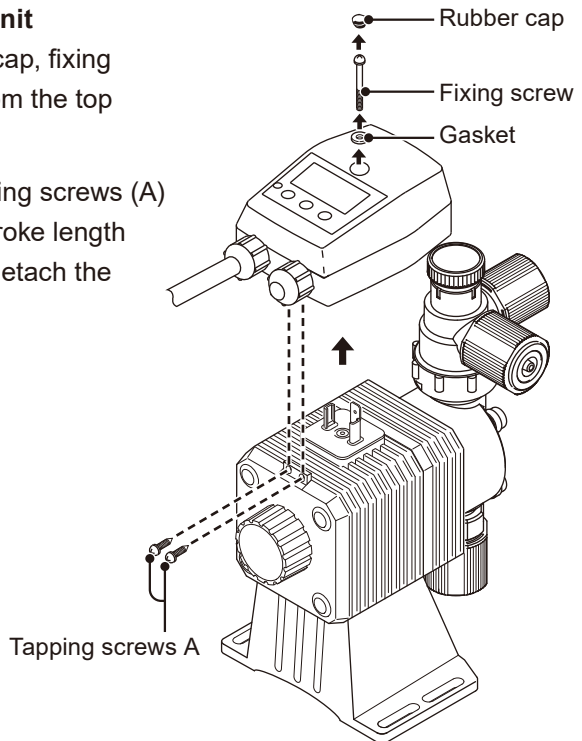

## 2 Loosen four (4) tapping screws (B) and open the controller cover

\*The controller cover can not be totally removed. The LCD display PCB in the controller cover is cabled to the main PCBA in the controller case.

\*The controller cover and the case are sealed by a case gasket. Make sure the gasket is in place when replacing the cover.

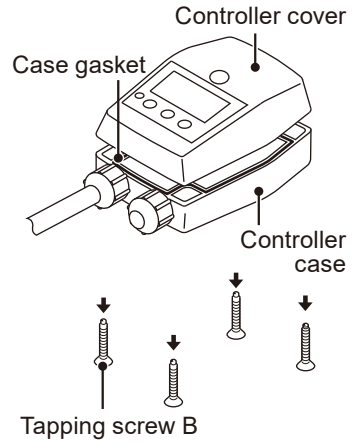

## 3 Remove the cable nut, the protective cap, and the cable gasket

\*The cap is not used after a cable is connected to the terminal.

\*Use a 20 mm spanner as necessary if the cable nut is stuck to the control unit.

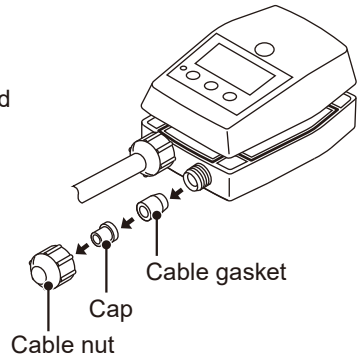

## 4 Pass an external signal cable into the cable nut and the cable gasket

\*The cable gasket has the mounting directions as shown right.

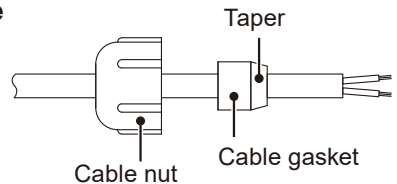

## 5 Connect the external signal cable

- a. Detach the plug from the socket.
- b. Use a precision screwdriver to connect signal wires to the plug.
- c. Replace the plug to the socket.
- d. Take up the slack of the cable.
- e. Hand-tighten the cable nut.

\*The cable is held to the case when cable nut is tightened over the cable gasket.

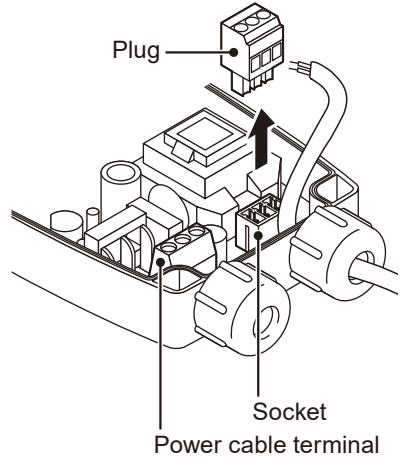

### Wiring diagram

When a no-voltage contact is used

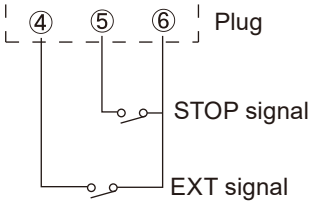

When an open collector signal is used

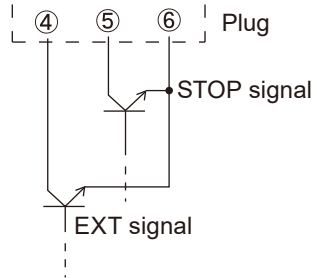

\*When an Iwaki LNB series flow meter (pulse output type) is used, connect both the red line and white line together to Terminal 4, and the black line to Terminal 6 as shown above.

## 6 Reassembly and remount the control unit

### Tightening torque

Fixing screw (control unit)	0.39 N•m
Tapping screw A (controller case)	0.39 N•m
Tapping screw B (controller cover)	0.8 N•m

### NOTE

Always check that gaskets (a rubber cap, fixing screw gasket and a case gasket) are fitted in place for ensuring water-/dust-tightness to the control unit.

# Operation

***This section describes pump operation and programming.  
Run the pump after pipework and wiring is completed.***

## Before operation

*First check tubing and wiring are correct. And then perform degassing and flow rate adjustment before starting operation.*

### ***Points to be checked***

*Before operation, check if:*

- Liquid level in a supply tank is enough.
- Tubing is securely connected and is free from leakage and clogging.
- Discharge/suction valves are opened.
- A power voltage is in the allowable range.
- Electrical wiring is correct and is free from the risk of short circuit and electrical leakage.

### ***Retightening of pump head fixing bolts***

#### **Important**

The pump head fixing bolts may loosen when plastic parts creep due to temperature change in storage or in transit. This could lead to a chemical leak. Tighten the bolts diagonally and evenly by the rated torque at each model before initial operation and at regular intervals (every three months).

#### **Tightening torque**

Model code	Torque	Bolts
EHN-BN09/-BN11/-BN16/-BN21	2.16 N•m	M4 Hex. socket head bolt
EHN-BN31	2.55 N•m	M4 Hex. socket head bolt
EHN-CN16/-CN21	2.16 N•m	M4 Hex. socket head bolt
EHN-CN31	2.55 N•m	M4 Hex. socket head bolt
EHN-CN36	2.55 N•m	M5 Hex. socket head bolt

## ■ Use of hexagon wrench instead of a torque wrench

Fasten the fixing bolts as tight as can be with the straight long part of a hexagon wrench (a) and further turn the bolts clockwise 90 degrees with the short part (b).

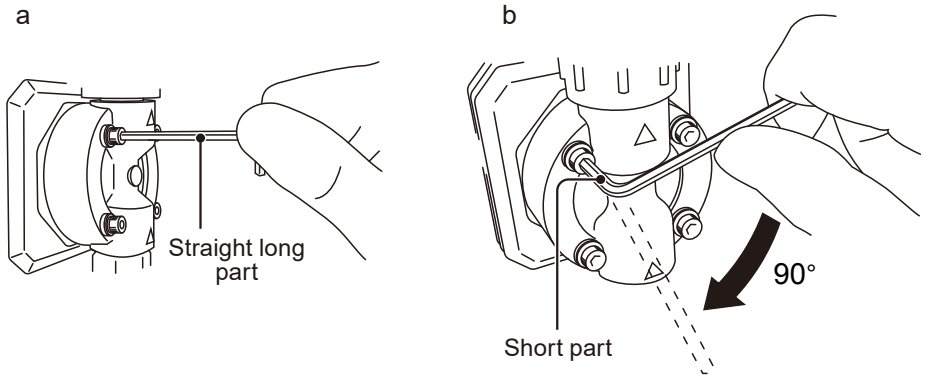

## ***Degassing***

*The gas in the pump and tubing is the obstacle to liquid delivery and needs to be expelled before the pump is started. Especially:*

- When the pump starts to run for the first time
- When a flow rate is too low
- After liquid is replaced in a supply tank
- After a long period of stoppage
- After maintenance and inspection are performed

### NOTE

- Both gas and chemical come out together through an air bleed tube. Make sure the end of the tube is located in a supply tank or a container.
- Some chemicals are harmful or attack dry end parts. Wash/wipe chemicals off immediately if getting wet.

## ■ EHN-BN\_/-CN\_MR and EHN-BN09VC models

### Points to be checked

- An air bleed tube is connected to the pump.

Air bleed tube

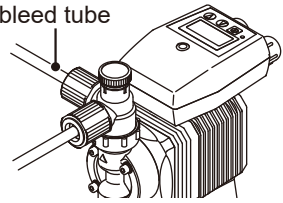

### 1 Turn on power

The ON LED and the display are turned ON.

\*The pump waits in the MAN mode when turning on power with a default setting or calls up a previous mode at the last shutoff

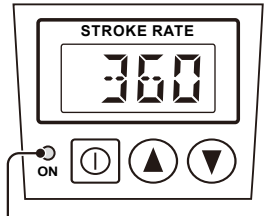

ON LED

### 2 Set a stroke rate to 360spm

See the "Stroke rate adjustment" section on page 50 for detail.

### 3 Rotate the adjusting screw two revolutions anticlockwise to open the air vent port

\*Do not rotate it three revolutions. The adjusting screw may come off with solution spray.

Adjusting screw

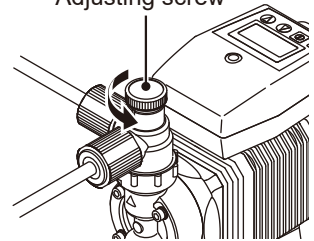

### 4 Push the start/stop key and run the pump for more than ten minutes

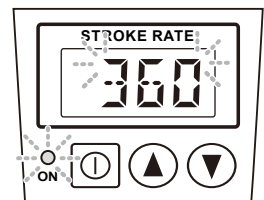
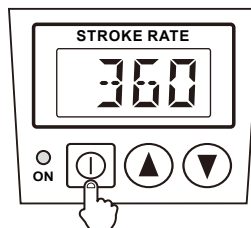

**5** Push the start/stop key and stop the pump

**6** Rotate the adjusting screw clockwise to close the air vent port

**7** Check liquid is delivered to the discharge line

Degassing must be repeated until liquid is outputted from the pump outlet.

**8** Check connections for leakage

Degassing has now been completed.

■ **EHN-BN\_/-CN\_MKR and EHN-BN\_/-CN\_FC models**

No air vent port is provided to these pumps; however, you can expel air, taking steps below. Otherwise, you can branch the main flow line (discharge side) for establishing an open-ended air vent line.

**1** Reroute the discharge tube back to the supply tank or container

\*If the check valve or the back pressure valve is already installed, solution in the discharge line may be under pressure. This is not totally recommended; however, you have no choice but to remove the check valve or the back pressure valve while solution is pressurised. Use a cloth around the outlet fitting nut many turns until it can be a protection against solution spray and the check valve is safely removed.

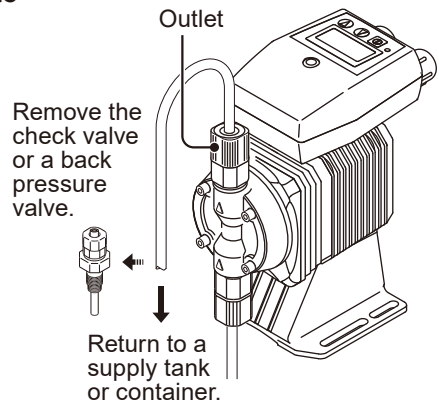

## 2 Turn on power

The ON LED and the display are turned ON.

\*The pump waits in the MAN mode when turning on power with a default setting or calls up a previous mode at the last shutoff

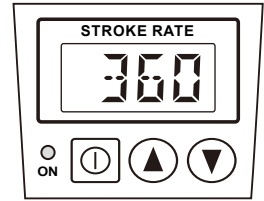

## 3 Set a stroke rate to 360spm (or 300 spm for the EHN VS-V/PS-V models)

See the "Stroke rate adjustment" section on page 50 for detail.

## 4 Push the start/stop key and run the pump for more than ten minutes

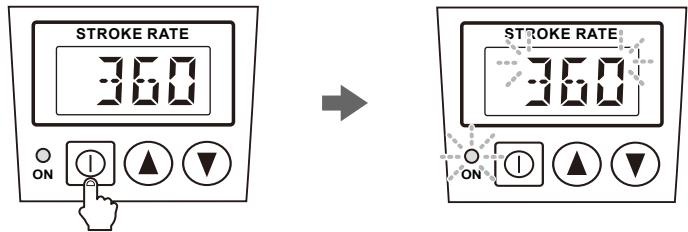

## 5 Push the start/stop key and stop the pump

## 6 Check liquid is delivered to the discharge line

Degassing must be repeated until liquid is outputted from the pump outlet.

## 7 Check connections for leakage

Degassing has now been completed.

## ■ EHN-BN\_/-CN\_ SH models

### Points to be checked

- An air bleed tube is connected to the pump.

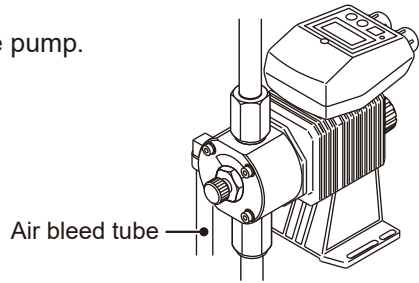

## 1 Turn on power

The ON LED and the display are turned ON.

\*The pump waits in the MAN mode when turning on power with a default setting or calls up a previous mode at the last shutoff

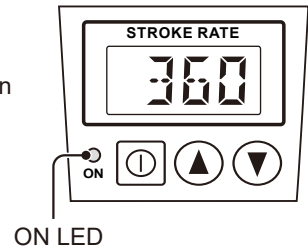

## 2 Set a stroke rate to 360spm

See the "Stroke rate adjustment" section on page 50 for detail.

## 3 Rotate the adjusting screw anticlockwise to set to OPEN so that the air vent port opens

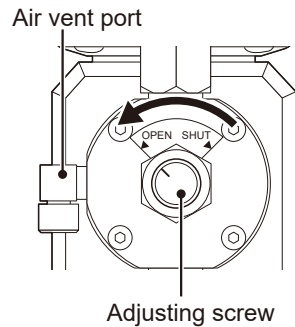

- 4** Push the start/stop key and run the pump for more than ten minutes

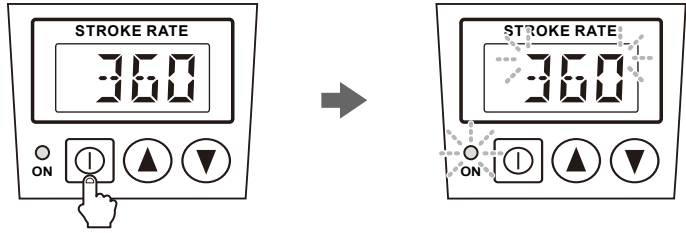

- 5** Push the start/stop key and stop the pump

- 6** Rotate the adjusting screw clockwise to set to SHUT so that the air vent port closes

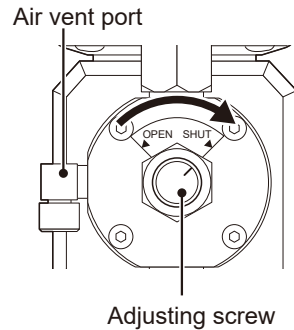

- 7** Check liquid is delivered to the discharge line

Degassing must be repeated until liquid is outputted from the pump outlet.

- 8** Check connections for leakage

Degassing has now been completed.

## **Flow rate adjustment**

---

*The flow rate can be changed by a stroke rate and a stroke length adjustment.*

The stroke rate represents the pump speed in spm (stroke per minute). The stroke rate adjustment is the main way to adjust the flow rate from the pump.

The stroke length represents the moving distance of the plunger. The widest moving distance is defined as 100% stroke length. The stroke length adjustment is used for determining the optimal flow volume per stroke (fine adjustment of the pump flow).

First adjust a flow rate with stroke rate adjustment. Use stroke length adjustment for the range where stroke rate adjustment can not reach. Note the optimal stroke length change with operating conditions and liquid characteristics.

### **1 Change the stroke rate with the stroke length 100% to the specified level**

See the "Stroke rate adjustment" section on page 50 and the "Stroke length adjustment" section on page 52 for detail.

### **2 Measure the flow rate**

### **3 If the flow rate is lower/higher than the specified level, increase/decrease the stroke rate and measure the pump flow again**

### **4 Change a stroke length for fine adjustment**

### **5 Measure the pump flow again to see the specified level is obtained**

## Flow rate, stroke rate and stroke length

### BN type

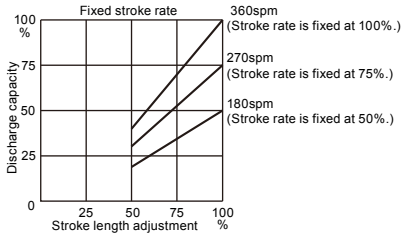

### CN type

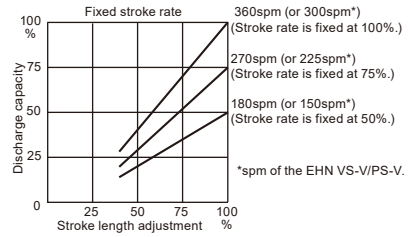

## Precautions of flow rate adjustment

### • When back pressure is high

Set stroke length to 100% and adjust the pump flow by changing the stroke rate.

### • When each dose greatly affects a chemical reaction in neutralization or titration application

Shorten the stroke length to reduce the flow rate per stroke. And then adjust the pump flow by changing the stroke rate.

### • When handling liquids that generate gas bubbles (sodium hypochlorite or hydrazine solution).

Set the stroke length to 100% and adjust the pump flow by changing the stroke rate. Note air lock may occur when the stroke length is set too short.

## ■ Stroke rate adjustment

The stroke rate can be set by keypad operation from 1 to 360spm (or 1 to 300spm for the EHN VS-V/PS-V models). The relation between the flow rate\* and the stroke rate is shown as below.

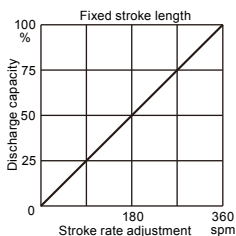

\*The nameplate shows the maximum (100%) output with the full stroke rate and length.

## 1 Turn on power and call up manual mode

Enter manual mode to show a stroke rate (spm) on the screen.

- Push the start/stop key when the pump is in the EXT mode.
- When "STOP" or "-STOP" appears on the screen, see page 72 to cancel the condition.

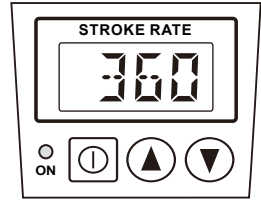

## 2 Use the UP or DOWN key to adjust a stroke rate

- The stroke rate increases/decreases by 1spm every time the key is pushed.
- Press and hold either key for three seconds for quick change. Quick change stops at 1 or 360(/300\*)spm and then skips to 360(/300\*) or 1spm when the key is released once and pushed again.

\*The spm range of the EHN VS-V/PS-V models is 1 to 300 spm.

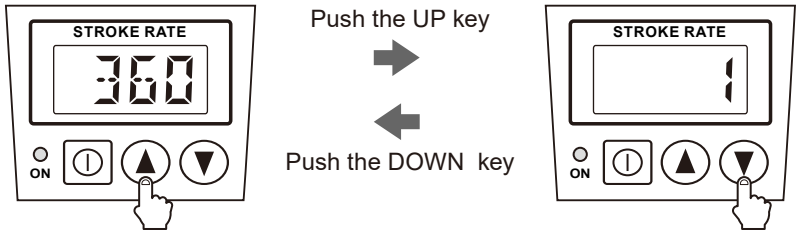

## 3 Push the start/stop key

The ON LED and the stroke rate blink at each stroke during operation.

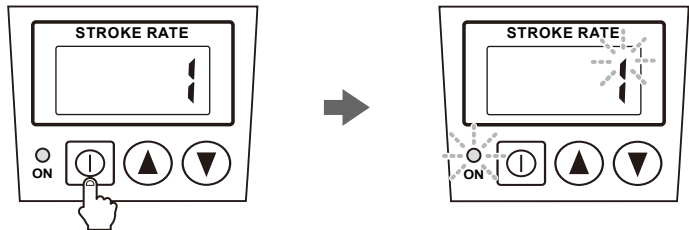

## ■ Stroke length adjustment

The stroke length can be adjusted when the moving distance of the plunger is changed with the stroke length adjusting knob.

The stroke length adjustment range is 50-100% for the BN type, 40-100% for the CN type. The relation between the flow rate\* and the stroke length is shown as below.

BN Type

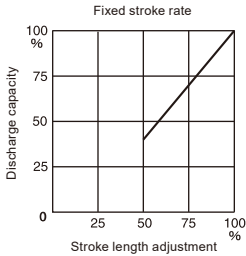

CN type

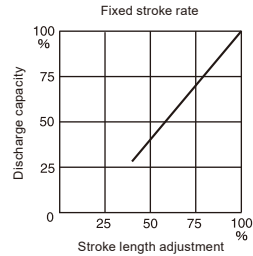

\*The nameplate shows the maximum (100%) output with the full stroke rate and length.

### NOTE

---

Do not rotate the stroke length adjusting knob when the pump is not running.

---

# 1 Turn on power and push the start/stop key to run the pump

The ON LED and the stroke rate blink during operation.

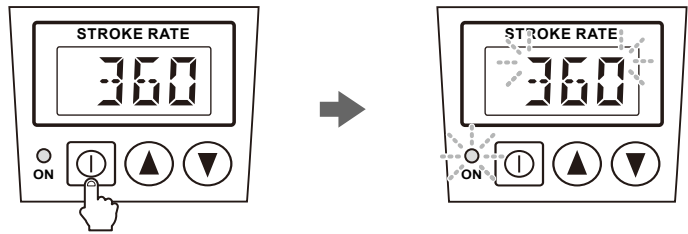

# 2 Rotate the stroke length knob to determine liquid volume per stroke

Stroke length knob

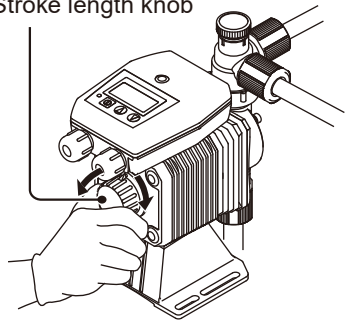

## ***Before a long period of stoppage (one month or more)***

---

### **Clean wet ends and the inside of tubing:**

- Run the pump with clean water for about 30 minutes to rinse chemicals off from the pump head and piping.

### **Before unplugging the pump:**

- Always stop the pump by key operation and wait for three seconds before unplugging the pump. Otherwise, the last key operation may not be put in memory. In this case the pump unintentionally starts to run as powered on, discharging liquid.

### **When the pump does not transfer liquid:**

- Clean the valve sets and remove foreign matters.
- If gas is in the pump head, expel gas and readjust a flow rate. See the "De-gassing" section on page 43 and the "Flow rate adjustment" section on page 49 for detail.

## Operation programming

Operation at each mode is individually set and controlled by keypad operation.  
Select a proper mode to make optimal operation.

### Default setting and Setting range

Parameters	Default settings	Setting ranges	Step
Stroke rate (MAN speed)* <sup>1</sup>	360(or 300* <sup>2</sup> )	1-360(or 300* <sup>2</sup> )	1* <sup>3</sup>
Multiply/Divide selection	/NNN	/NNN, XNNN	-
Divisor	1	1-999	1* <sup>3</sup>
Multiplier	1	1-999	1* <sup>3</sup>
EXT mode display selection	E-EX	E-EX/E-SP	-
Anti-chattering time* <sup>4</sup>	T-5	T-5/T-10/T-50	-
STOP function	M-OF	M-ON/M-OF	-

\*<sup>1</sup> Used as the upper limit spm in EXT mode.

\*<sup>2</sup> spm for the EHN VS-V/PS-V models

\*<sup>3</sup> The stroke rate increases/decreases by 1spm every time the up or down key is pushed. Press and hold either key 3 seconds for quick change.

\*<sup>4</sup> It becomes more immune to contact bounce/electrical noise with the longer anti-chattering time but then can ignore any pulse length shorter than the threshold. The "T-5", "T-10", and "T-50" thresholds individually stand for 5, 10, and 50 msec pulse length. Select the minimum allowable threshold to any actual pulse inputted (the actual pulse length must be longer than the threshold).

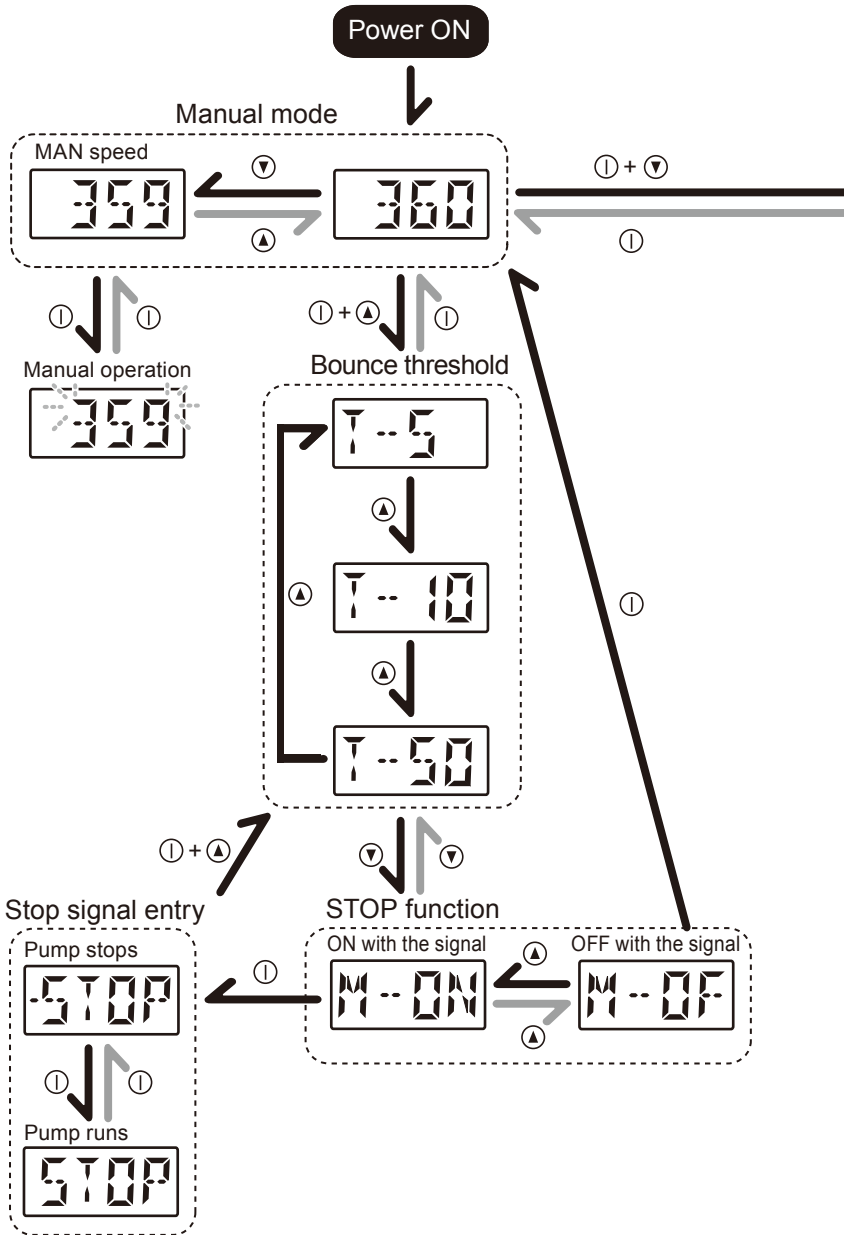

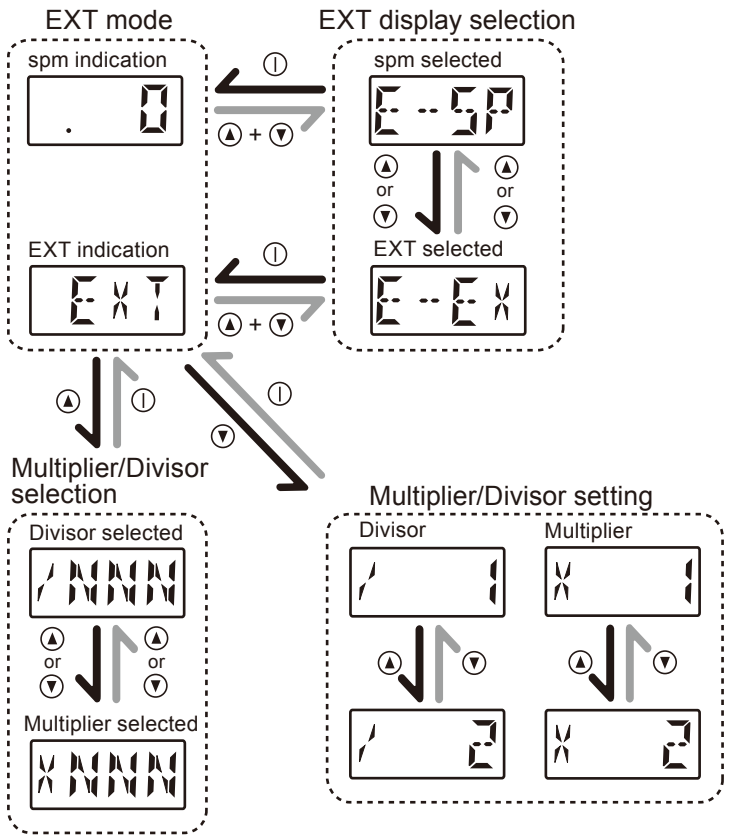

### Keypad lock

Any key operation is ineffective once keypads are locked.

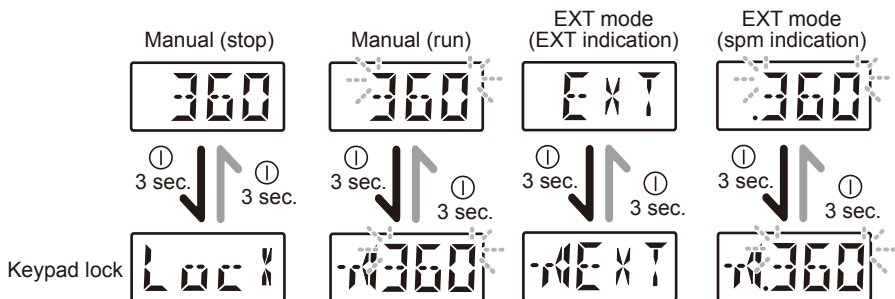

1

## Turn on power

The ON LED and the display are turned ON.

\*The pump waits in the MAN mode when turning on power with a default setting or calls up a previous mode at the last shutoff.

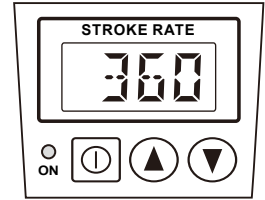

2

## Enter manual mode

Move to the next step when the pump is already in the manual mode.

**When "EXT" or ".0"-"360" is on the screen:**

Push the start/stop key once to enter the wait state in manual mode.

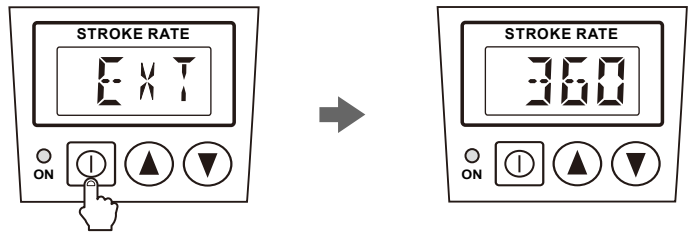

**When "STOP" or "-STOP" is on the screen:**

Cancel the STOP function. See page 72.

### 3 Use the UP or DOWN key to adjust a stroke rate

- The stroke rate increases/decreases by 1spm every time the key is pushed.
- Press and hold either key for three seconds for quick change. Quick change stops at 1 or 360spm and then skips to 360 or 1spm when the key is released once and pushed again.

\*The spm range of the EHN VS-V/PS-V models is 1 to 300spm.

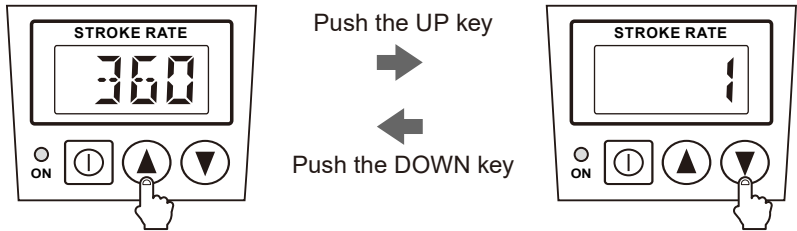

### 4 Push the start/stop key

The ON LED and the stroke rate blink at each stroke during operation.

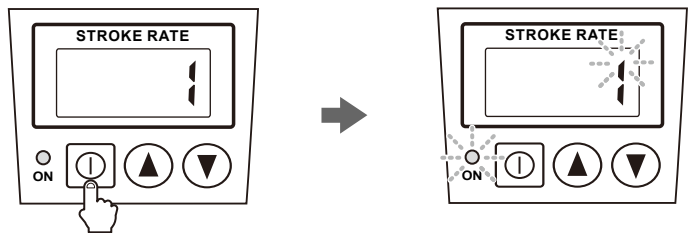

## EXT operation

The pump operation is controlled by the external (pulse) signal.

### ■ EXT mode

Set the upper limit spm (MAN speed) and enter EXT mode. Note that the pump starts to run in sync with the external signal as entering EXT mode.

## NOTE

- The pump does not run over the manual stroke rate (MAN speed). If the MAN speed is set to 200spm, for example, the pump does not run over the speed with any multiplier or divisor settings.
- The MAN speed skips from 360spm (/1spm) to 1spm (/360spm) when the up (/down) key is pushed once. The spm range of the EHN VS-V/PS-V models is 1 to 300spm.

### 1 Turn on power and call up manual mode

Enter manual mode to show a stroke rate (spm) on the screen.

- Push the start/stop key when the pump is in the EXT mode.
- When "STOP" or "-STOP" appears on the screen, see page 72 to cancel the condition.

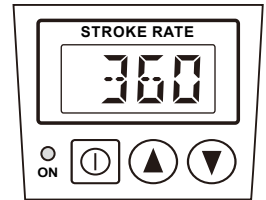

### 2 Use the UP or DOWN key to set the MAN speed

Push the start/stop key and stop the pump when it is running.

- The stroke rate increases/decreases by 1spm every time the key is pushed.
- Press and hold either key for three seconds for quick change. Quick change stops at 1 or 360spm and then skips to 360 or 1spm when the key is released once and pushed again.

\*The spm range of the EHN VS-V/PS-V models is 1 to 300 spm.

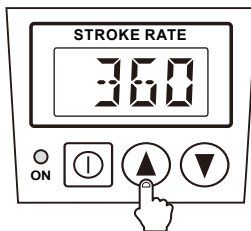

Push the UP key



Push the DOWN key

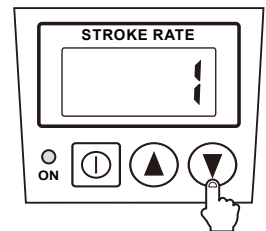

### 3 Push the DOWN key while pressing the start/stop key to enter EXT mode

Note that the pump starts to run in sync with the external signal as entering EXT mode.

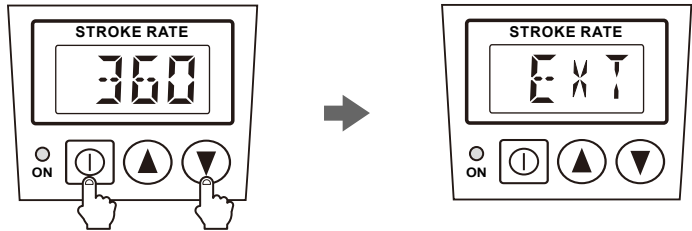

#### ■ EXT mode setting

The following features can be set for the EXT operation.

##### • Multiplier setting

The number of strokes per signal is entered.

##### • Divisor setting

The number of signals per stroke is entered.

##### • Anti-chattering setting

The minimum allowable pulse length is set to prevent the adverse affect by chattering (contact bounce) and electrical noise.

##### • Display selection

Either "EXT" or "spm" indication is selected for EXT mode.

#### NOTE

Any EXT mode setting will not be entered unless the start/stop key is pushed for confirmation. Also, note if the pump is unplugged before the start/stop key is pushed, your setting will be no longer effective.

#### Glossary

##### Chattering

The rapid, repetitive noises made from contact bounce of the mechanical relay or switch. Chattering can cause malfunction to electric devices or parts.

## Multiplier setting

The pump runs at the MAN speed for the preset multiplier (1-999 strokes) per incoming external signal. Set a multiplier per pulse in advance of operation.

### NOTE

Do not enter the external signal before this setting is completed.

#### 1 Enter EXT mode

- Push the DOWN key while pressing the start/stop key to move from manual mode to EXT mode.
- Push the start/stop key and stop the pump before setting is performed.

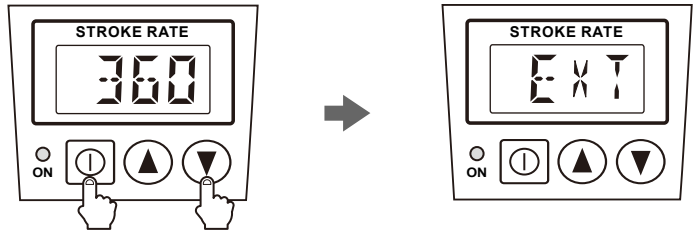

#### 2 Push the UP key and enter the multiplier/divisor selection

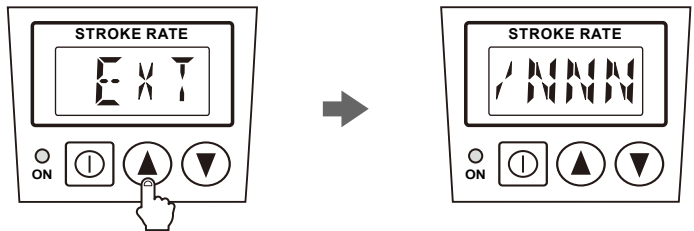

#### 3 Select "X NNN" (multiplier)

"X NNN" (multiplier) or "/ NNN" (divisor) can be selected with the UP and DOWN keys.

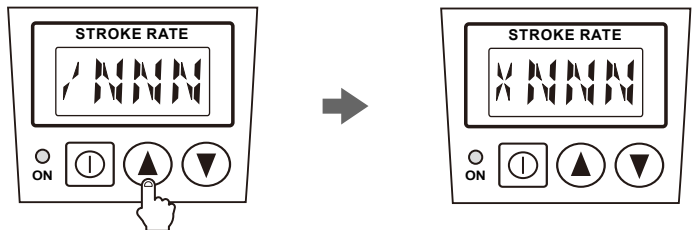

**4 Push the start/stop key to return to EXT mode**

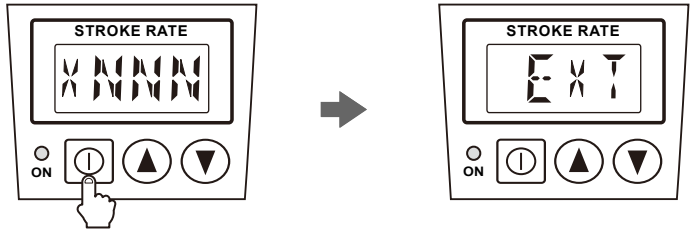

**5 Push the DOWN key and call up the multiplier setting screen**

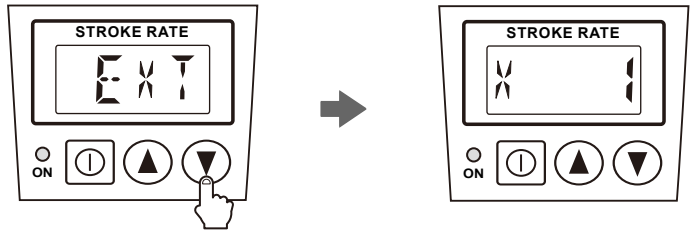

**6 Use the UP or DOWN key to set a multiplier**

- A multiplier increases/decreases as the UP or DOWN key is pushed.
- Press and hold either key for three seconds for quick change. Quick change stops at 1 multiplier or 999 multipliers and then skips to 999 multipliers or 1 multiplier when the key is released once and pushed again.

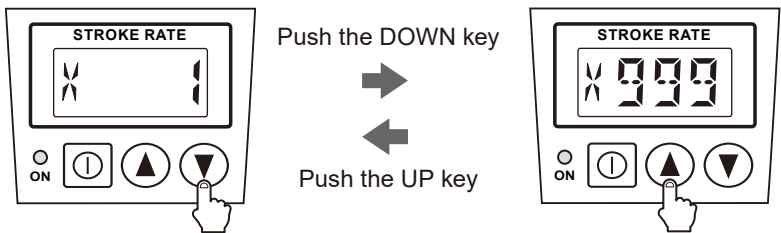

## 7 Push the start/stop key to return to EXT mode

The pump runs according to the multiplier setting.

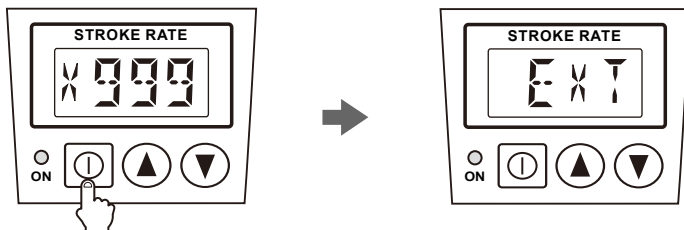

## Divisor setting

The pump runs for the preset divisor (1-999 pulse rates) at every incoming external signals. Set a divisor per stroke in advance of operation.

### NOTE

- If a divisor is set to 1, the pump speed equals to the external pulse rate (1:1 operation). This operation, however, may be upset when the pulse rate has exceeded the MAN speed and when the extra signals are cancelled. Although this is not malfunction, use of the multiplier is recommended to ensure steady 1:1 operation.
- Do not enter the external signal before this setting is completed.

## 1 Enter EXT mode

- Push the DOWN key while pressing the start/stop key to move from manual mode to EXT mode.
- Push the start/stop key and stop the pump before setting is performed.

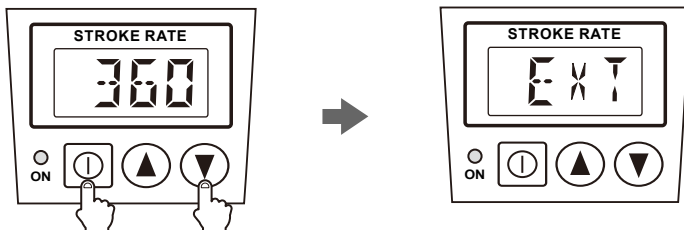

## 2 Push the UP key and enter the multiplier/divisor selection

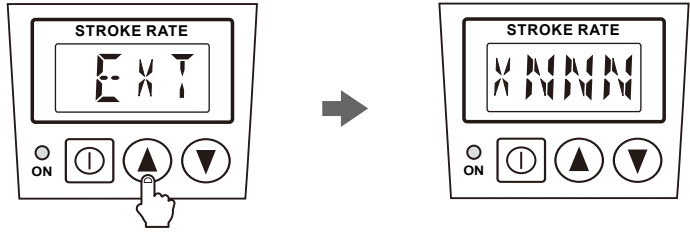

## 3 Select "/ NNN"(divisor)

"X NNN" (multiplier) or "/ NNN" (divisor) can be selected with the UP and DOWN keys.

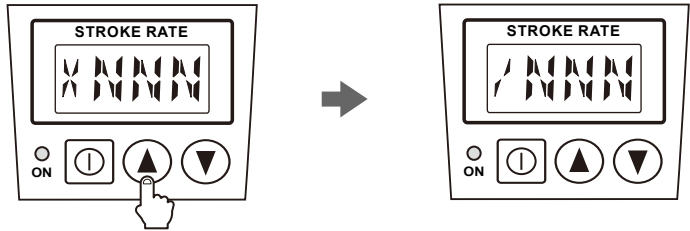

## 4 Push the start/stop key to return to EXT mode

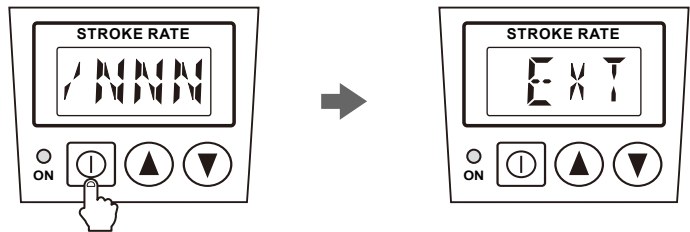

## 5 Push the DOWN key and call up the divisor setting screen

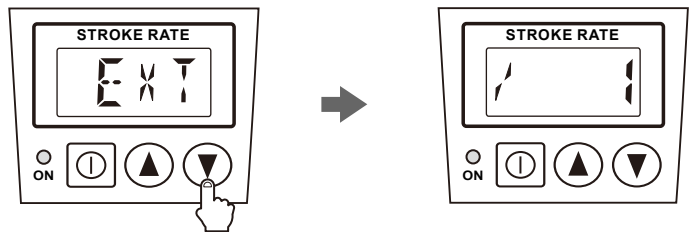

## 6 Use the UP or DOWN key to set a divisor

- A divisor increases/decreases as the UP or DOWN key is pushed.
- Press and hold either key for three seconds for quick change. Quick change stops at 1 divisor or 999 divisors and then skips to 999 divisors or 1 divisor when the key is released once and pushed again.

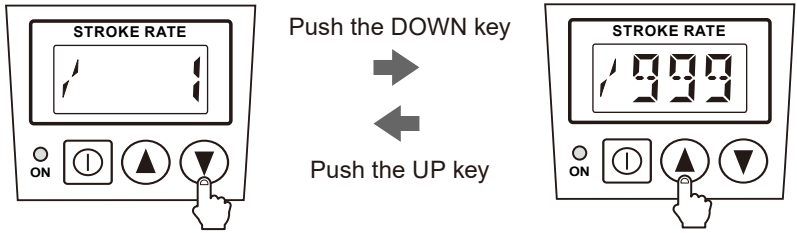

## 7 Push the start/stop key to return to EXT mode

The pump runs according to the divisor setting.

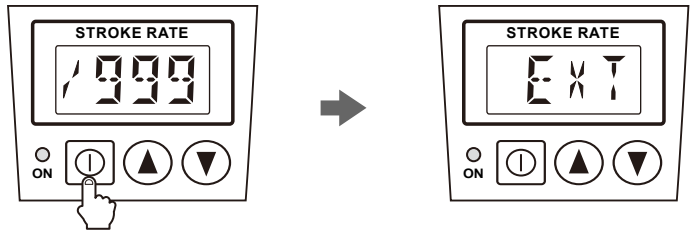

### Anti-chattering setting

The minimum allowable pulse length should be set to prevent the adverse effect of chattering (contact bounce) and electrical noise. The factory default setting is "T-5 (5msec)". Select the "T-10 (10msec)" or "T-50 (50msec)" choice accordingly if a longer pulse length than the default is inputted.

#### NOTE

When this product is used with the EUC-70P controller, select "T-5" (default setting). The pump may not run with "T-10" or "T-50" bounce threshold.

## 1 Enter manual mode

Push the start/stop key to return to manual mode if the pump is in EXT mode.

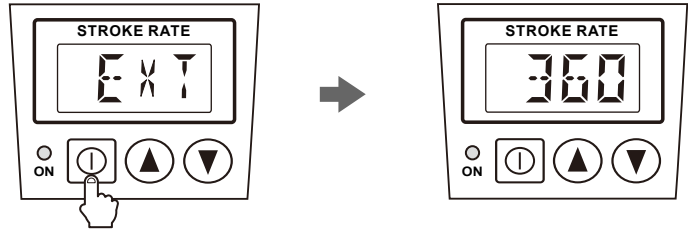

## 2 Push the UP key while pressing the start/stop key to call up the anti-chattering setting mode

"T-5" (default setting), "T-10" or "T-50" appears on the screen.

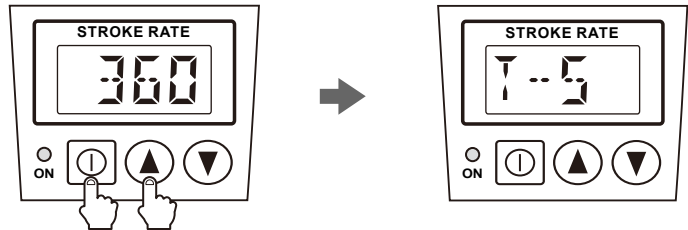

## 3 Push the UP key and select a pulse length threshold

The UP key to change between the "T-5", "T-10" and "T-50" thresholds.

\*It becomes more immune to contact bounce/electrical noise with the longer anti-chattering time but then can ignore any pulse length shorter than the threshold. The "T-5", "T-10", and "T-50" thresholds individually stand for 5, 10, and 50 msec pulse length. Select the minimum allowable threshold to any actual pulse inputted (the actual pulse length must be longer than the threshold).

\*When this product is used with the EUC-70P controller, select "T-5" (default setting). The pump may not run with "T-10" or "T-50".

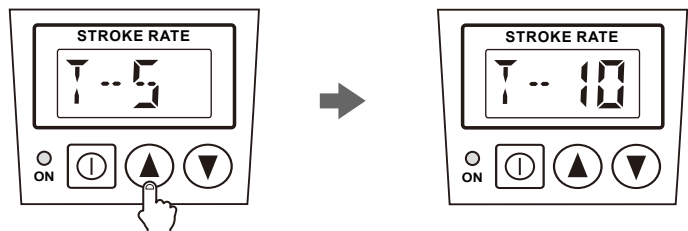

## 4 Push the start/stop key to return to manual mode

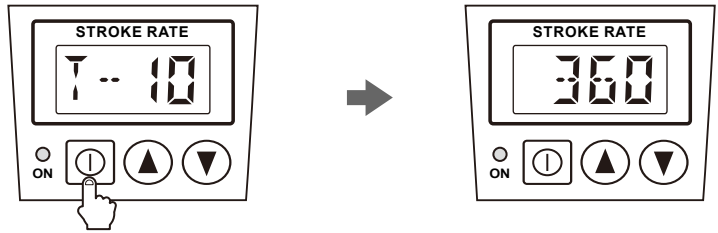

### Display selection

Either "EXT" or "spm" indication is selected for EXT mode.

The pump shows "EXT" on its screen when "E-EX" is selected, or a current pump speed when "E-SP" selected

#### NOTE

- With "E-SP" selected, the screen shows the current pump speed (It is not the real-time value of the multiplier/divisor and the number of external signals being inputted.).
- Do not enter the external signal before this setting is completed.

## 1 Enter EXT mode

- Push the DOWN key while pressing the start/stop key to move from manual mode to EXT mode.
- Push the start/stop key and stop the pump before setting is performed.

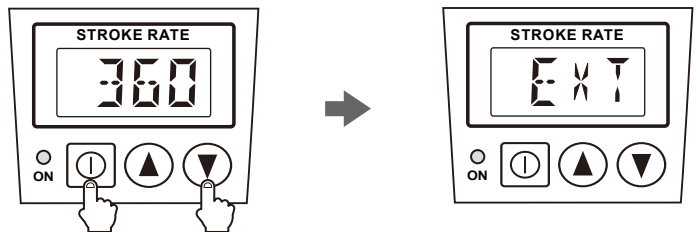

- 2** Push the DOWN key while pressing the UP key to call up the display selection mode

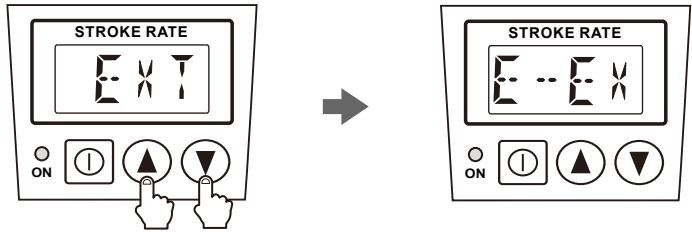

- 3** Push the UP or DOWN key to select "E-EX" (EXT indication) or "E-SP" (spm indication)

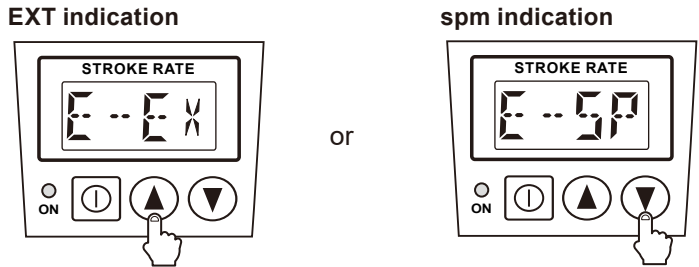

- 4** Push the start/stop key to return to EXT mode

When spm indication is selected

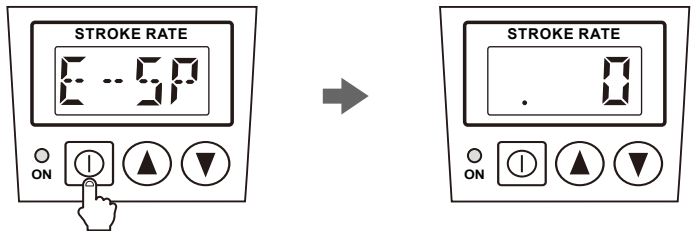

"EXT" appears on the screen when EXT indication is selected.

## STOP function

The start/stop of the pump operation can be controlled by the external stop signal.

- **Stop signal input: "M-OFF"**

The pump stops while receiving the stop signal.

- **Stop signal input: "M-ON"**

The pump runs while receiving the stop signal.

### ■ STOP function setting

#### 1 Enter manual mode

Push the start/stop key to return to manual mode if the pump is in EXT mode.

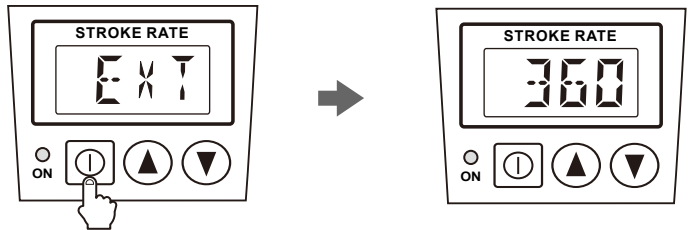

#### 2 Push the UP key while pressing the start/stop key to call up the bounce threshold setting mode

"T-5" (default setting), "T-10" or "T-50" appears on the screen.

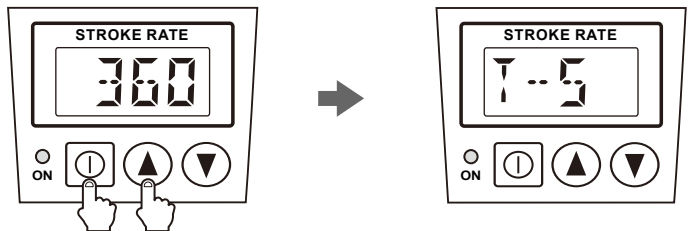

- 3** Push the **DOWN** key and call up the **STOP** function setting mode  
"M-OFF" (default setting) or "M-ON" appears on the screen.

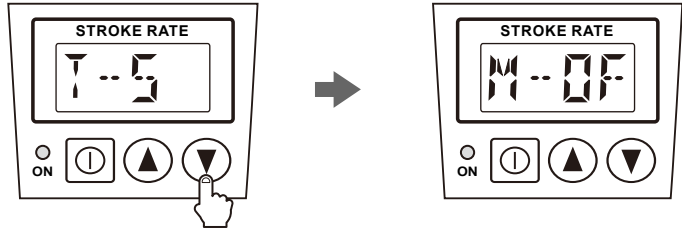

- 4** Push the **UP** key to select "M-OFF" (stop during the signal input) or  
"M-ON" (run during the signal input)

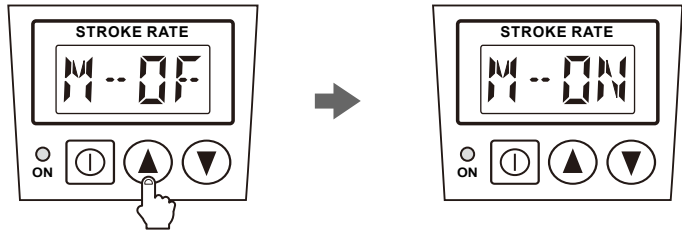

- 5** Push the **start/stop** key to return to manual mode

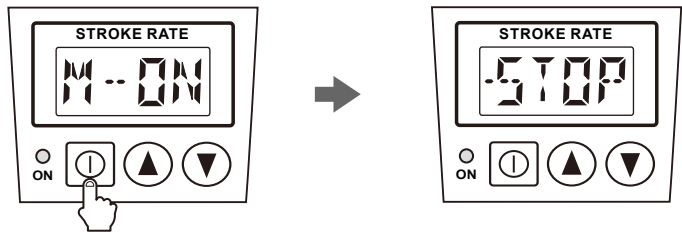

## ■ STOP function cancellation

A stop state can be cancelled if the current selection is changed.

Example) M-OF→M-ON  
M-ON→M-OF

### 1 Enter the wait state in the manual mode

Push the start/stop key when "STOP" is on the screen or when the pump is running or stopped in the EXT mode. "-STOP" appears on the screen.

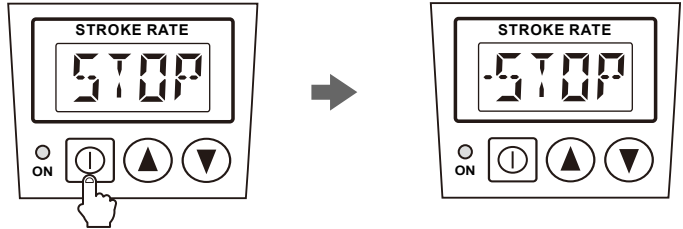

### 2 Push the UP key while pressing the start/stop key to call up the bounce threshold setting mode

"T-5" (default setting), "T-10", or "T-50" appears on the screen.

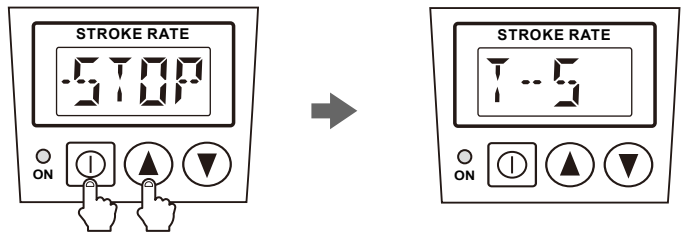

### 3 Push the DOWN key and call up the STOP function selection mode

"M-OF" (default setting) or "M-ON" appears on the screen.

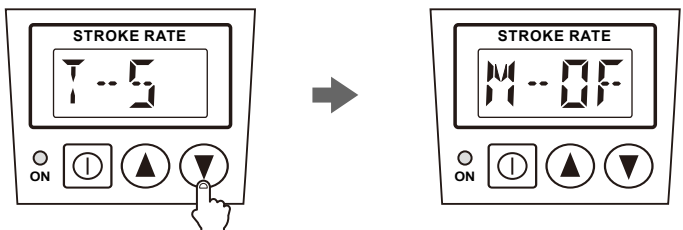

#### 4 Push the UP key and change the current selection

If "M-OF" is selected, change it to "M-ON". If "M-ON" is selected, change to "M-OF".

When "M-OF" is selected

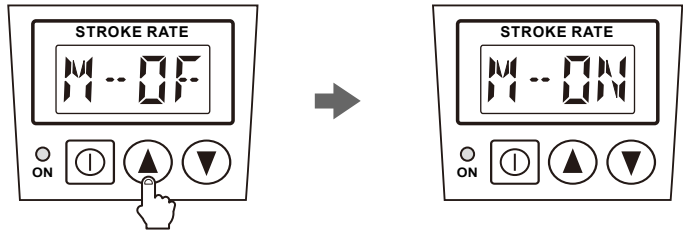

#### 5 Push the start/stop key to return to the manual mode

In this state the pump is stopped.

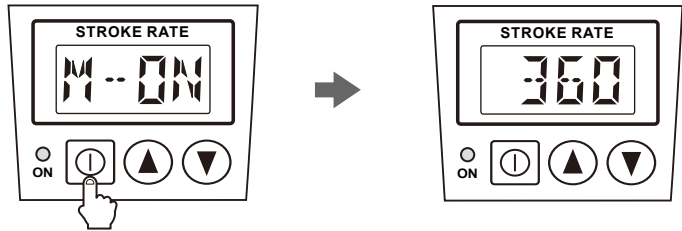

The STOP function now has been cancelled.

## Keypad lock

---

Keypad lock can be active in the following states for the prevention of erroneous key operation.

### Manual mode

Wait state

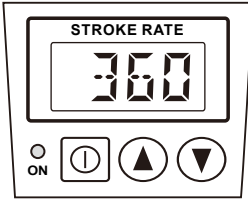

During operation

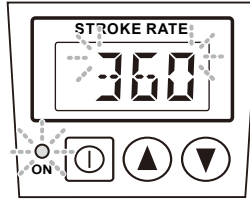

### EXT mode

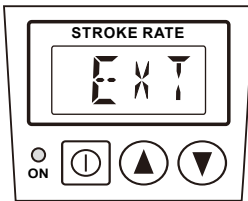

### NOTE

---

- Any key operation is not effective when keypads are locked. In an emergency, turn off the main power to stop operation. Keypads are locked again when the pump is powered.
  - The display shows "STOP" or "-STOP" when the keypads are locked while the pump is receiving the STOP signal. These display will change to the normal (keypad lock info as shown next page) once the stop signal is removed.
-

## ■ Keypad lock activation

### 1 Press and hold the start/stop key for three (3) seconds

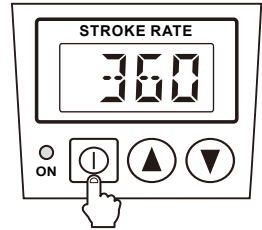

The following indication appears.

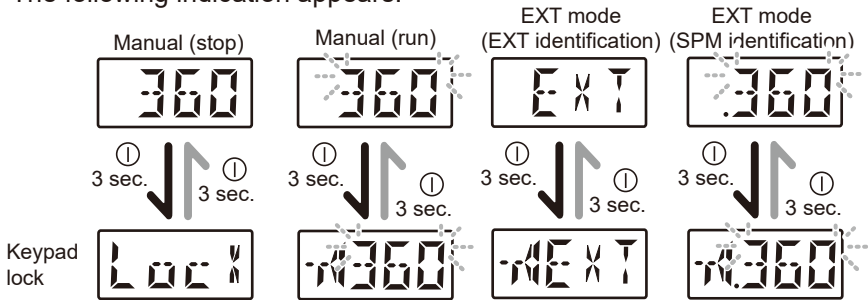

## ■ Keypad lock release

### 1 Press and hold the start/stop key for three (3) seconds

Keypad lock is released and key operation becomes effective.

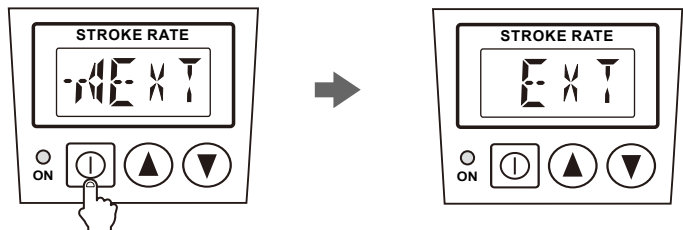

# Maintenance

***This section describes troubleshooting, inspection, wear part replacement, exploded views and specifications.***

## **!** Important

- Follow instructions in this manual for replacement of wear parts. Do not disassemble the pump beyond the extent of the instructions.
- Always wear protective clothing such as an eye protection, chemical resistant gloves, a mask and a face shield during disassembly, assembly or maintenance work. The specific solution will dictate the degree of protection. Refer to SDS precautions from the solution supplier.
- Risk of electrical shock. Be sure to turn off power to stop the pump and related devices before service is performed.

## **Before unplugging the pump**

Always stop the pump by key operation. And wait for three seconds before unplugging the pump. Otherwise, the last key operation to stop the pump may not be put in memory. In this case the pump unintentionally starts to run as powered on, discharging liquid.

## Troubleshooting

First check the following points. If the following measures do not help remove problems, contact us or your nearest distributor.

States	Possible causes	Solutions
The pump does not run. (LED does not light. Blank screen.)	Power voltage is too low.	• Observe the allowable voltage range of 90-264VAC
	The pump is not powered.	• Check the switch if it is installed. • Correct wiring • Replace a broken wire to new one.
	An electronic circuit in the control unit is failed.	• Replace the control unit.
Liquid can not be pumped up.	Air lock in the pump	• Expel air. See page 43.
	Stroke length is too short.	• Run the pump with full stroke length and then with adjusted length.
	Air ingress through a suction line.	• Correct tubing.
	A valve set is installed upside down.	• Reinstall the valve set.
	Valve gaskets are not installed.	• Install valve gaskets.
	Foreign matters are stuck in the pump head valves.	• Take apart, inspect and clean the valves. Replace as necessary.
Flow rate fluctuates.	A valve ball is stuck on a valve seat.	• Take apart, inspect and clean the valve. Replace as necessary.
	Air stays in the pump head.	• Expel air. See page 43.
	Overfeeding occurs.	• Mount a check valve. See page 31.
	Foreign matters are stuck in the pump head valves.	• Take apart, inspect and clean the valves. Replace as necessary.
	Diaphragm is broken.	• Replace diaphragm.
	Pressure fluctuates at an injection point.	• Maintain a pressure constant at an injection point by optimising tubing or by relocating the point.
Liquid leaks.	The fitting or the air vent body is loose.	• Retighten them.
	The pump head is loose.	• Retighten the pump head. See page 43.
	O rings or valve gaskets are not installed.	• Install O rings and valve gaskets in place.
	Diaphragm is broken.	• Replace the diaphragm.
	Excessive discharge pressure.	• Check that a discharge line is not closed. • Check if tubing is not clogged.

States	Possible causes	Solutions
Pump does not run in the EXT mode.	In the EXT mode, the number of divisors is too large to make a stroke.	• Reduce the divisors.
	Anti-chattering time is too large.	• Select "T-5", "T-10", or "T-50" thresholds depending on the actual pulse length of 5, 10, and 50 msec.
	EXT signal wires are connected incorrectly.	• Correct signal wires.
	STOP signal that is dominant over EXT signal is turned ON.	• Cancel the STOP signal.
	M-ON logic is selected to STOP function.	• Set it to M-OFF.
	Control unit has failed (e.g. voltage signal has been applied to EXT/ STOP terminal inadvertently.)	• You need to replace with the new controller. Contact us.
Pump runs too slow in EXT mode.	MAN speed is set too low.	• Increase MAN speed.
Pump runs too fast in EXT mode.	Multiplier is set too high.	• Reduce multiplier.
	Switching noise from signal line	• Select a wider anti-chattering time.
Keypad operation is rejected.	Keypad is temporarily locked out.	• Unlock the keypad.
Pump runs unintentionally by STOP signal.	M-ON logic is selected to STOP function.	• Set it to M-OFF.
Pump stops unintentionally by STOP signal.	M-OFF logic is selected to STOP function.	• Set it to M-ON.

## Inspection

Perform daily and periodic inspection to keep pump performance and safety.

### Daily inspection

Check the following points. If you notice any abnormal or dangerous conditions, suspend operation immediately and inspect/solve problems. See the troubleshooting section as necessary.

When wear parts come to the life limit, replace them with new ones. Contact us or your nearest distributor for detail.

No.	States	Points to be checked	How to check
1	Pumping	• If liquid is pumped.	Flow meter or visual inspection
		• If the suction and discharge pressure are normal.	Check specifications.
		• If liquid has deteriorated, crystallized or precipitated.	Visual or audio inspection
2	Noise and vibration	• If abnormal noise or vibration occurs. They are signs of abnormal operation.	Visual or audio inspection
3	Air ingress from pump head joints and a suction line	• If pumped liquid includes air bubbles, check the line for leakage and loose connection and retighten as necessary.	Visual or audio inspection

### Periodic inspection

Retighten the pump head mounting bolts evenly to the following torque in diagonal order.

\*Mounting bolts may loosen in operation. How fast the bolts start to loosen is depending on operating conditions.

#### Tightening torque

Model code	Torque	Bolts
EHN-BN09/-BN11/-BN16/-BN21	2.16 N•m	M4 Hex. socket head bolt
EHN-BN31	2.55 N•m	M4 Hex. socket head bolt
EHN-CN16/-CN21	2.16 N•m	M4 Hex. socket head bolt
EHN-CN31	2.55 N•m	M4 Hex. socket head bolt
EHN-CN36	2.55 N•m	M5 Hex. socket head bolt

\*A hexagon wrench can be used for a torque wrench. See page 43.









## Wear part replacement

*To run the pump for a long period, wear parts need to be replaced periodically. It is recommended that the following parts are always stocked for immediate replacement. Contact us or your nearest distributor for detail.*

### **!** Precautions

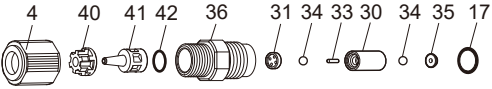
- Solution in the discharge line may be under pressure. Release the pressure from the discharge line before disconnecting plumbing or disassembly of the pump to avoid solution spray.
- Rinse wet ends thoroughly with tap water.
- Each time the pump head is taken apart, replace the diaphragm, O rings, and valve sets with new ones.

# Wear part list

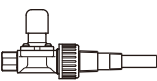
		Parts						# of parts	Estimated life
Pump	Valve set	VC/VS PC/PS	PP	VS-V PS-V	09VC	FC	SH	2 sets	8000 hours
		Diaphragm							
O ring					-		See page 95 or later.		
Bolt gasket							1		
Auto air vent valve set (EHN-NAE only)							1 set		
CAN check valve	Check valve poppet (with an O ring)							1 set	
	Check valve spring							1	
	CS check valve	EHN-SH only						1	
	BVC back pressure valve	EHN-FC only							1

**Maintenance**

\*Wear part duration varies with the pressure, temperature and characteristics of liquid.  
 \*The estimated life is calculated based on the continuous operation with clean water at ambient temperature.

## Before replacement

First release pressure from the pump head and the discharge line.

### 1 Stop the pump operation

### 2 Rotate the adjusting screw two revolutions anticlockwise to open the air vent port

#### NOTE

Do not rotate it three revolutions from the closed position. Or liquid may come out from the adjusting screw.

\*The air vent adjusting screw is NOT provided or NOT capable to release discharge line pressure to the pump models EHN\_MKR and EHN-BN\_-/CN\_FC/SH. Establish an air vent line with an air vent valve and adjust the valve manually to expel gas from the pump and system before operation (see the sketch on page 30 and 31 as well.). In the case the air vent line is unable to be built, you have no choice but to remove the discharge line while it is under pressure. This is not totally recommended; however, use a cloth around the outlet fitting nut many turns until it can be a protection against solution spray and the discharge tube is safely removed.

### 3 Check the pump head and the discharge line are depressurized

Liquid pressure is released from the air vent line in the form of solution spray.

#### NOTE

If pressurized liquid is not expelled, run the pump with an opened air vent line until pressure is removed.

### ■ Necessary tools (Width across flat)

Model	Spanner			
	Fitting nut	Fitting	Lock nut	Air vent body B
EHN_MR	27 mm	24 mm	38 mm	21 mm
EHN_MKR			-	-
EHN-BN-/CN 11/21	FC	22 mm	-	-
EHN-BN-/CN 31/36		24 mm	-	-
EHN-BN-/CN 11/21	SH	-	21 mm	-
EHN-BN-/CN 31/36		-	27 mm	-
EHN-BN09	22 mm	17 mm	32 mm	*

\*Use 17 mm socket wrench instead of a spanner.

# Valve set replacement

## ■ Discharge valve set disassembly/assembly

### Necessary tools

- An adjustable wrench or a spanner
- 17 mm socket wrench for the EHN-BN09 models
- A pair of tweezers

\*Unfix the pump base before disassembly.

### EHN-BN\_/-CN\_ MR and EHN-BN09 models

- 1** Use an adjustable wrench or a following spanner to remove the fitting nut, the discharge tube, and the air bleed tube

Model	Width across flat
EHN_MR	27 mm
EHN-BN09	22 mm

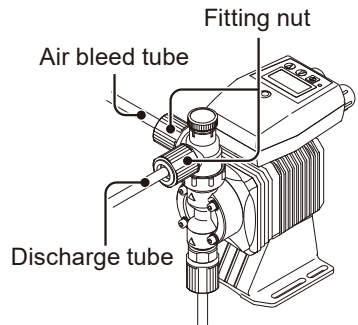

- 2** Turn the lock nut anticlockwise with an adjustable wrench or a following spanner and remove the air vent body A

Model	Width across flat
EHN_MR	38 mm
EHN-BN09	32 mm

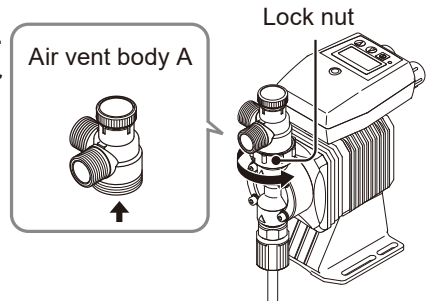

### 3 Use a following tool to remove the air vent body B

Model	Tool	Width across flat
EHN_MR	Adjustable wrench or spanner	21 mm
EHN-BN09	Socket wrench	17 mm

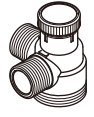

Air vent body B

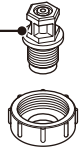

### 4 Pull out the valve set with a pair of tweezers

### 5 Build up the new valve set into the pump head and hand-tighten the air vent body B through the lock nut as far as it will go

Retighten it by a further  $\frac{1}{4}$  turn with an adjustable wrench or a following spanner.

Model	Tool	Width across flat
EHN_MR	Adjustable wrench or spanner	21 mm
EHN-BN09	Socket wrench	17 mm

\*Arrange the valve set in the correct parts order and direction. A leak or an insufficient flow may result.

\*Be sure to fit O rings and gaskets in place.

\*Keep the valve set clean.

Air vent body B

Lock nut

Valve set

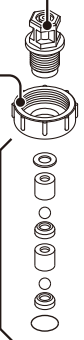

VC/VS/PC/PS

### 6 Remount the air vent body A and connect tubes

Tighten the lock nut, air vent body A, and fitting nut with an adjustable wrench or a following spanner.

Model	Fitting nut	Lock nut
EHN_MR	27 mm	38 mm
EHN-BN09	22 mm	32 mm

\*See the tube connection section on page 25 for detail.

- 1** Use an adjustable wrench or a following spanner to remove the fitting nut and the discharge tube

Model	Width across flat
EHN_MKR	27 mm
EHN-11/21FC	22 mm
EHN-31/36FC	24 mm

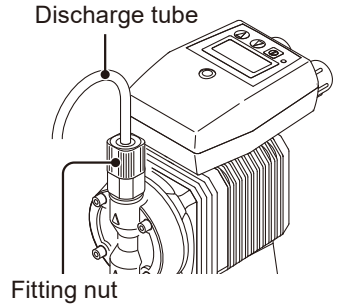

- 2** Use an adjustable wrench or a following spanner to remove the fitting

Model	Width across flat
EHN_MKR	24 mm
EHN-11/21FC	22 mm
EHN-31/36FC	24 mm

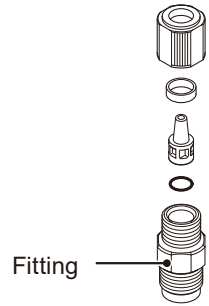

- 3** Pull out the valve set with a pair of tweezers

## 4 Build up the new valve set into the pump head and hand-tighten the fitting as far as it will go

Retighten it by a further  $\frac{1}{4}$  turn with an adjustable wrench or a following spanner.

Model	Width across flat
EHN_MKR	24 mm
EHN-11/21FC	22 mm
EHN-31/36FC	24 mm

\*Arrange the valve set in the correct parts order and direction. A leak or an insufficient flow may result.

\*Be sure to fit O rings and gaskets in place.

\*Keep the valve set clean.

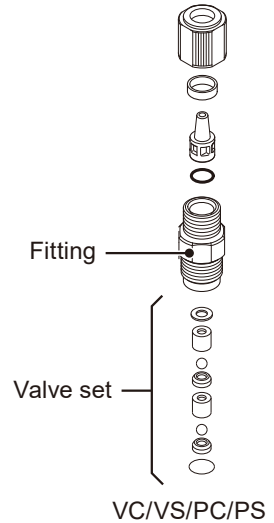

## 5 Reconnect the discharge tube

\*See the tube connection section on page 25 for detail.

### EHN-BN\_-/CN\_ SH models

## 1 Remove the suction, discharge and air bleed pipe

## 2 Use an adjustable wrench or a following spanner to remove the fitting

Model	Width across flat
EHN-11/21	22 mm
EHN-31/36	27 mm

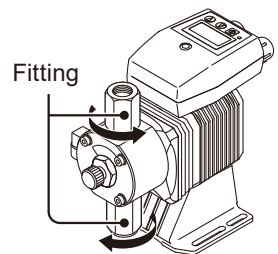

## 3 Pull out the valve set with a pair of tweezers

## 4 Build up the new valve set into the fitting and hand-tighten it to the pump head as far as it will go

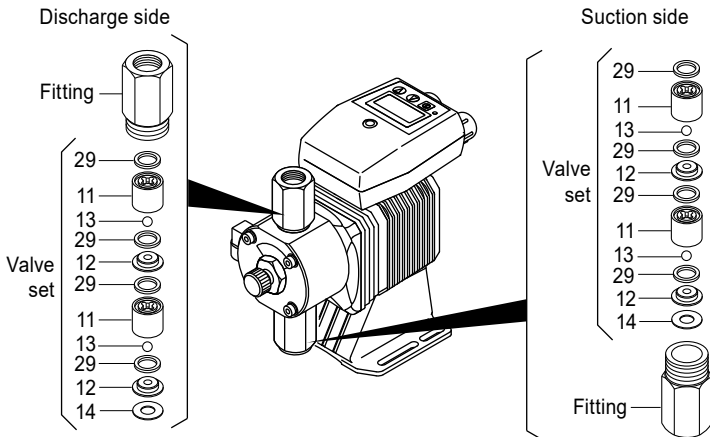

Retighten it by a further  $\frac{1}{4}$  turn with an adjustable wrench or a spanner.

Model	Width across flat
EHN-11/21	21 mm
EHN-31/36	27 mm

\*Arrange the valve set in the correct parts order and direction. A leak or an insufficient flow may result.

\*Be sure to fit O rings and gaskets in place.

\*Keep the valve set clean.

### NOTE

Do not drop the valve set.

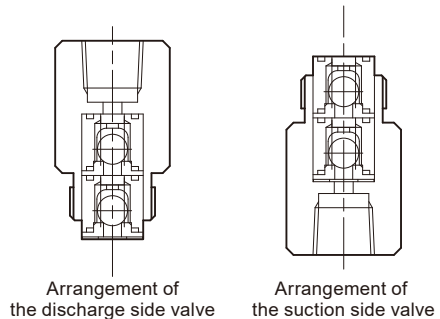

## 5 Reconnect the suction, discharge and air bleed pipe

\*See the thread connection section on page 30 for detail.

## ■ Suction valve set disassembly/assembly

### NOTE

Be careful not to drop the valve set.

- 1 Use an adjustable wrench or a following spanner to remove the fitting nut and the suction tube**

Model	Width across flat
EHN-BN/-CN 11/21 FC	22 mm
EHN-BN/-CN 31/36 FC	24 mm
EHN-BN09	22 mm
Any other models	27 mm

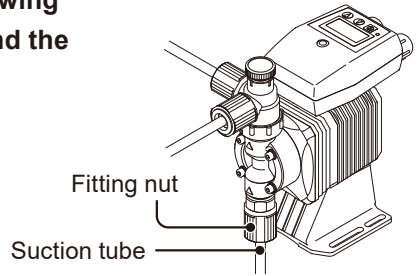

- 2 Use an adjustable wrench or a following spanner to remove the fitting**

Model	Width across flat
EHN-BN/-CN 11/21 FC	22 mm
EHN-BN/-CN 11/21 SH	21 mm
EHN-BN/-CN 31/36 SH	27 mm
EHN-BN09	17 mm
Any other models	24 mm

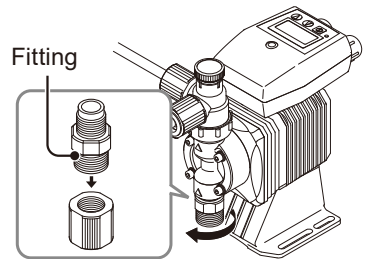

- 3 Pull out the valve set with a pair of tweezers**

## 4 Build up the new valve set into the fitting and hand-tighten it into the pump head as far as it will go

Retighten it by a further  $\frac{1}{4}$  turn with an adjustable wrench or a spanner.

Model	Width across flat
EHN-BN/-CN 11/21 FC	22 mm
EHN-BN/-CN 11/21 SH	21 mm
EHN-BN/-CN 31/36 SH	27 mm
EHN-BN09	17 mm
Any other models	24 mm

\*Arrange the valve set in the correct parts order and direction. A leak or an insufficient flow may result.

\*Be sure to fit O rings and gaskets in place.

\*Keep the valve set clean.

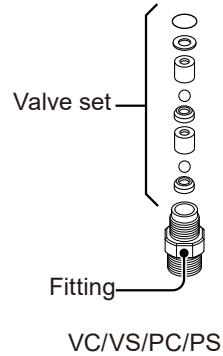

## 5 Reconnect the suction tube

\*See the tube connection section on page 25 for detail.

### ■ Auto vent valve set disassembly/assembly for the EHN\_NAE models

#### Necessary tools

- An adjustable wrench or a spanner
- A pair of tweezers

## 1 Use an adjustable wrench or a 27mm spanner to loosen the fitting nut and remove the air bleed tube

\*Be careful not to get wet with a residual chemical.

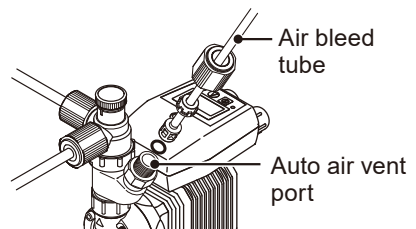

- 2** Use an adjustable wrench or a 24mm spanner to remove the fitting from the fitting adaptor

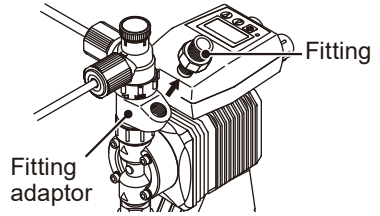

- 3** Pull out the auto air vent valve with a pair of tweezers from the fitting adaptor

- 4** Remove the tape from the new auto air vent assy

\*Do not drop the auto air vent valve from the fitting.

- 5** Hand-tighten the new auto air vent assembly into the fitting adaptor as far as it will go

Retighten it by a further  $\frac{1}{4}$  turn with an adjustable wrench or a 24mm spanner.

\*Arrange the auto air vent valve in the correct parts order and direction so the auto degassing works correctly. See page 103 for the correct order.

\*Be sure to fit O rings in place.

\*Keep the auto air vent valve clean.

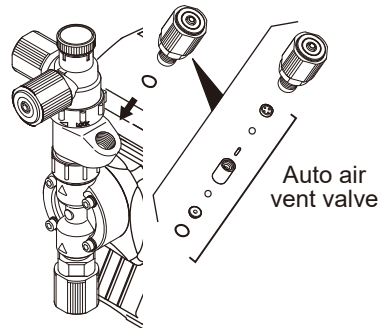

- 6** Reconnect the air bleed tube

\*See the tube connection section on page 25 for detail.

# Diaphragm/Bolt gasket replacement

## Necessary tools

- An adjustable wrench or a spanner
- A hexagon wrench
- A torque wrench
- A pair of tweezers

## NOTE

Pay attention not to lose diaphragm spacers. A few diaphragm spacers may be inserted between the retainer and plunger for the adjustment of a diaphragm location. Note that the number of diaphragm spacers provided varies at different pumps.

### 1 Run the pump and set the stroke length to 0%. Then stop the pump

\*Shorten the stroke length to 0% or just to the length that the diaphragm can be removed.

### 2 Use an adjustable wrench or a following spanner to loosen the fitting nuts and remove the suction tube, discharge tube, and air bleed tube

Model	Width across flat
EHN-BN/-CN 11/21 FC	22 mm
EHN-BN/-CN 31/36 FC	24 mm
EHN-BN09	22 mm
Any other models	27 mm

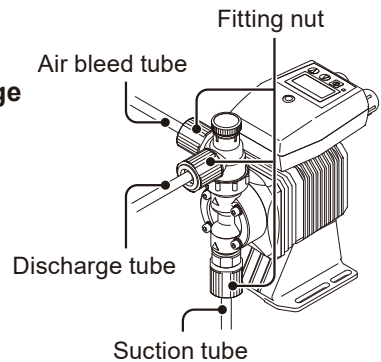

### 3 Remove the pump head with a hexagon wrench

\*Solution in the pump head may be under pressure. Loose the lower bolts first.

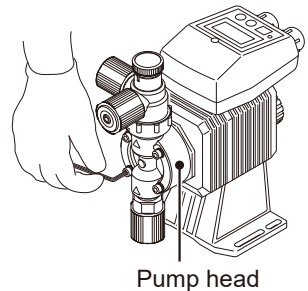

## 4 Pull out the bolt gasket with a pair of tweezers

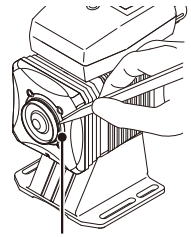

Bolt gasket

## 5 Unscrew the diaphragm from the plunger (pump shaft)

\*The retainer and the diaphragm spacer are inserted behind the diaphragm. Try not to lose them.

\*The diaphragm spacer adjusts the diaphragm to be seated properly. Some models may not include the spacer.

\*After removing the diaphragm, you can take out the front bracket. Try not to drop it.

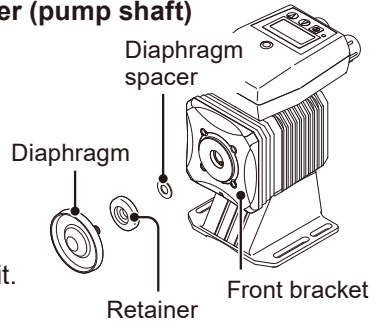

## 6 Install the retainer and then the diaphragm spacer (if any) to the diaphragm shaft

\*Fit the concave side of the retainer to the diaphragm first.

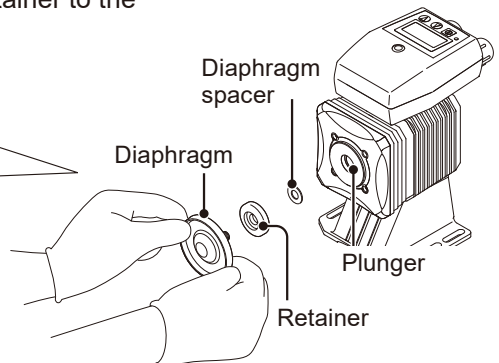
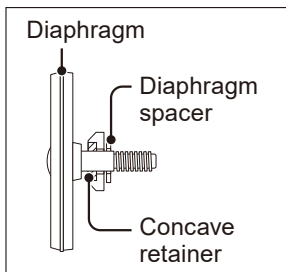

\*If the front bracket is removed, fit it as the drain hole directs downward and then install the diaphragm.

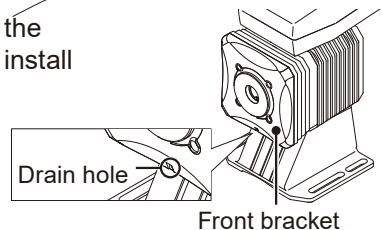

**7** Screw the new diaphragm into the plunger as far as it will go

**8** Run the pump and set the stroke length to 100%. Then stop the pump

**9** Fit a new bolt gasket into the front bracket groove

\*Ensure the open end of the bolt gasket directs downward. The raised bumps of the gasket mate with the front bracket.

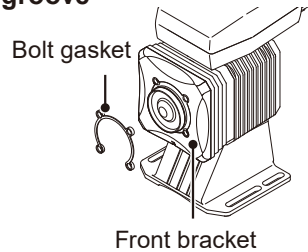

**10** Mount the pump head

Make sure the bolts seat against the bolt gasket or the bolt head is 11mm away from the pump head before tightening them. Tighten the bolts diagonally and evenly by the specified torque at each model.

\*Do not use excessive force when tightening the bolts. A damaged bolt gasket and insufficient sealing may result.

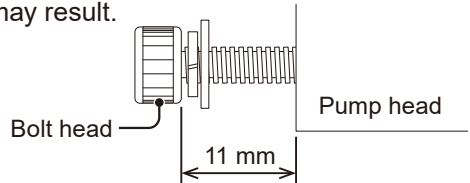

**Tightening torque**

Model code	Torque	Bolts
EHN-BN09/-BN11/-BN16/-BN21	2.16 N•m	M4 Hex. socket head bolt
EHN-BN31	2.55 N•m	M4 Hex. socket head bolt
EHN-CN16/-CN21	2.16 N•m	M4 Hex. socket head bolt
EHN-CN31	2.55 N•m	M4 Hex. socket head bolt
EHN-CN36	2.55 N•m	M5 Hex. socket head bolt

\*A hexagon wrench can be used for a torque wrench. See page 43.

**11** Reconnect the air bleed tube

\*See the tube connection section on page 25 for detail.

# Exploded view

## Pump head, Drive unit & Control unit

Do not disassemble the pump beyond the description in this manual.

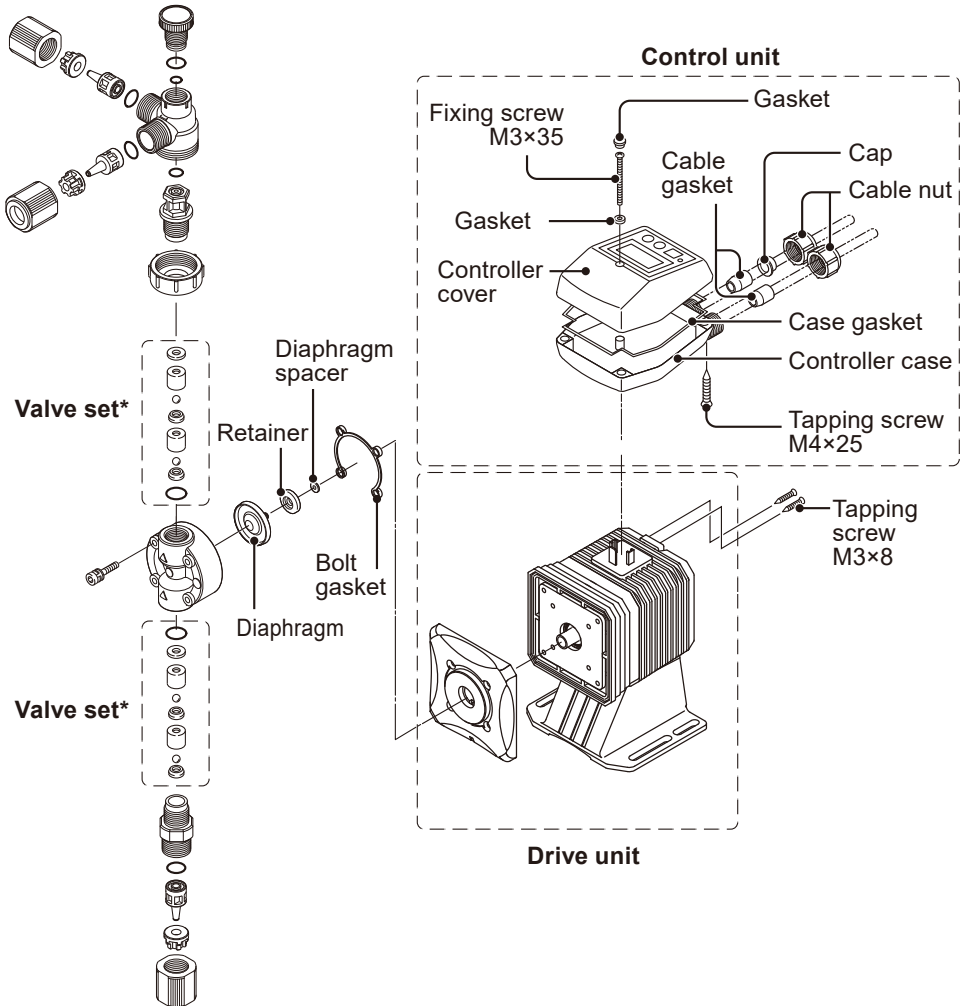

\* Wet end materials and their sizes differ with models. See the "Valve set replacement" section on page 83 for detail.

# Pump head

## ■ EHN-BN\_ /-CN\_ VC/VS/PC/PS M

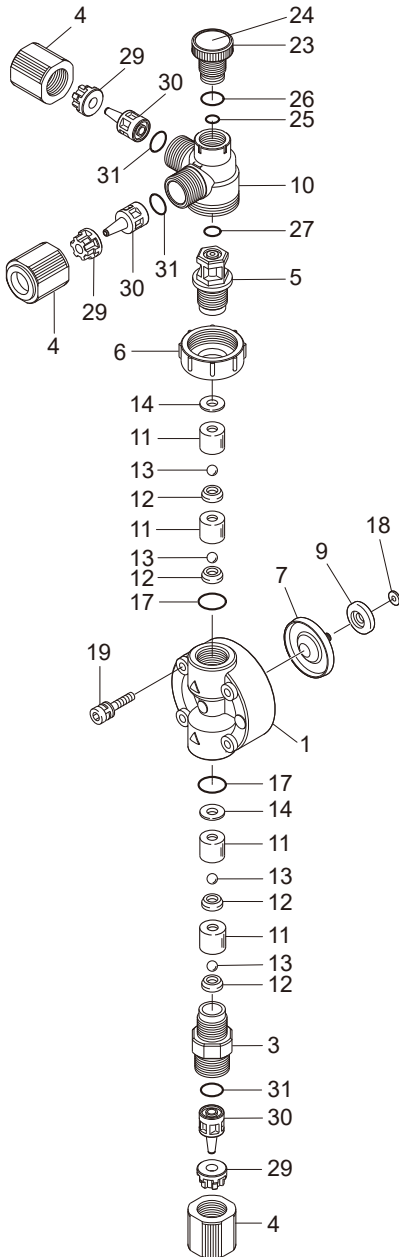

No.	Part names	# of parts
1	Pump head	1
3	Fitting	1
4	Fitting nut	3
5	Air vent body B	1
6	Lock nut	1
7	Diaphragm	1
9	Retainer	1
10	Air vent body A	1
11	Valve guide	4
12	Valve seat	4
13	Valve	4
14	Valve gasket	2
17	O ring	2
18	Diaphragm spacer	*
19	Hex. socket head bolt [PW•SW]	4
23	Adjusting screw	1
24	Name plate	1
25	O ring	1
26	O ring	1
27	O ring	1
29	Hose stopper	3
30	Hose adaptor	3
31	O ring	3

\*The number of diaphragm spacers varies with pump model.

■ EHN-BN31/-CN31/-CN36 VC/VS MK

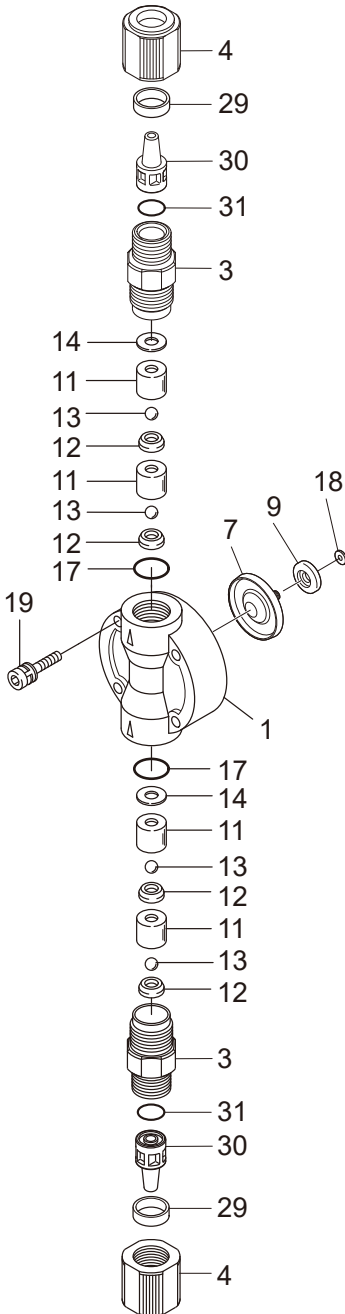

No.	Part names	# of parts
1	Pump head	1
3	Fitting	2
4	Fitting nut	2
7	Diaphragm	1
9	Retainer	1
11	Valve guide	4
12	Valve seat	4
13	Valve	4
14	Valve gasket	2
17	O ring	2
18	Diaphragm spacer	*
19	Hex. socket head bolt [PW•SW]	4
29	Hose stopper	2
30	Hose adaptor	2
31	O ring	2

\*The number of diaphragm spacers varies with pump model.

■ EHN-BN\_/-CN\_PP M

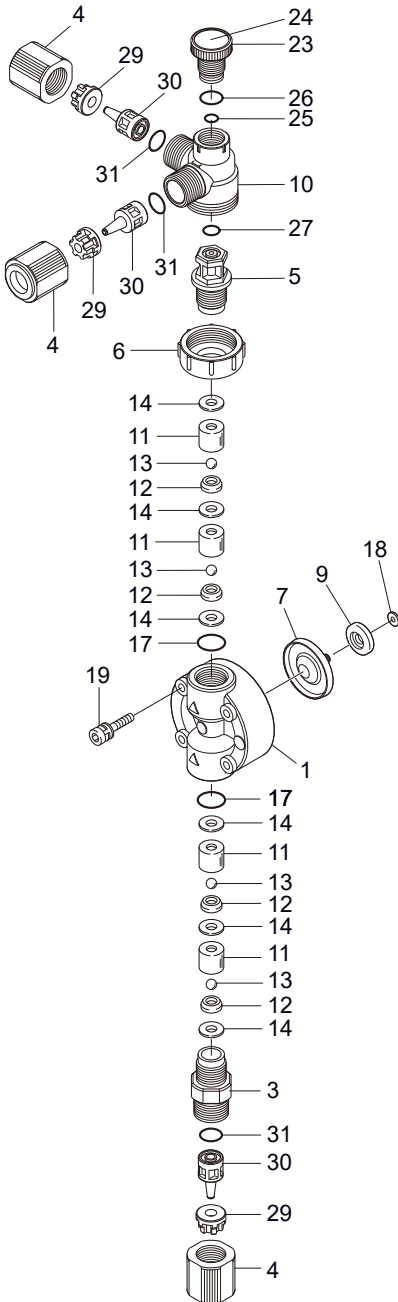

No.	Part names	# of parts
1	Pump head	1
3	Fitting	1
4	Fitting nut	3
5	Air vent body B	1
6	Lock nut	1
7	Diaphragm	1
9	Retainer	1
10	Air vent body A	1
11	Valve guide	4
12	Valve seat	4
13	Valve	4
14	Valve gasket	6
17	O ring	2
18	Diaphragm spacer	*
19	Hex. socket head bolt [PW•SW]	4
23	Adjusting screw	1
24	Name plate	1
25	O ring	1
26	O ring	1
27	O ring	1
29	Hose stopper	3
30	Hose adaptor	3
31	O ring	3

\*The number of diaphragm spacers varies with pump model.

## ■ EHN-BN11/-CN16 PS M-H

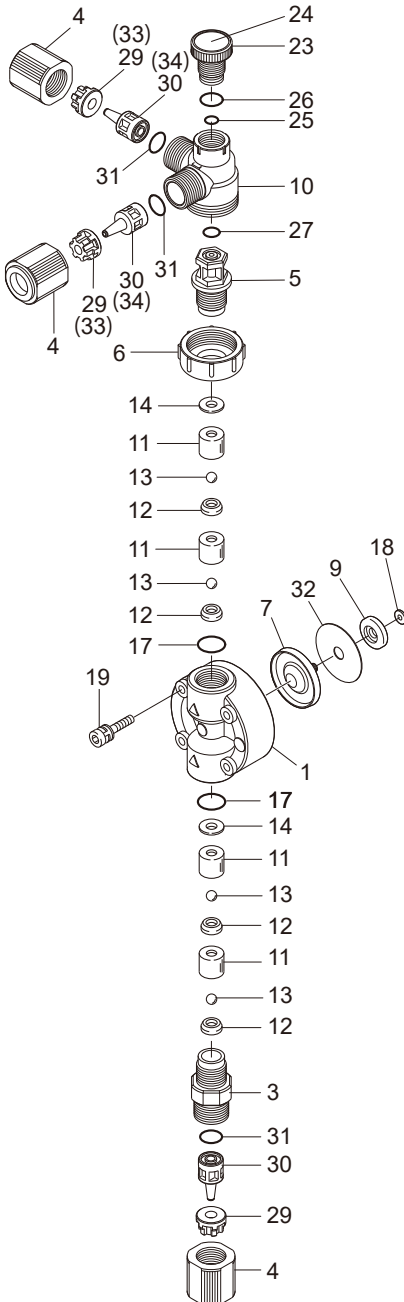

No.	Part names	# of parts
1	Pump head	1
3	Fitting	1
4	Fitting nut	3
5	Air vent body B	1
6	Lock nut	1
7	Diaphragm	1
9	Retainer	1
10	Air vent body A	1
11	Valve guide	4
12	Valve seat	4
13	Valve	4
14	Valve gasket	2
17	O ring	2
18	Diaphragm spacer	*
19	Hex. socket head bolt [PW•SW]	4
23	Adjusting screw	1
24	Name plate	1
25	O ring	1
26	O ring	1
27	O ring	1
29	Hose stopper	3 (1)
30	Hose adaptor	3 (1)
31	O ring	3
32	Rear diaphragm seat	1
(33)	Hose stopper	2
(34)	Hose adaptor	2

\*The number of diaphragm spacers varies with pump model.

\* The number of parts in brackets is for the models with the ½ tube size code (which has  $\varnothing 4 \times \varnothing 9$  inlet and  $\varnothing 4 \times \varnothing 6$  outlet/air vent).

■ EHN-BN\_/\_CN\_FC

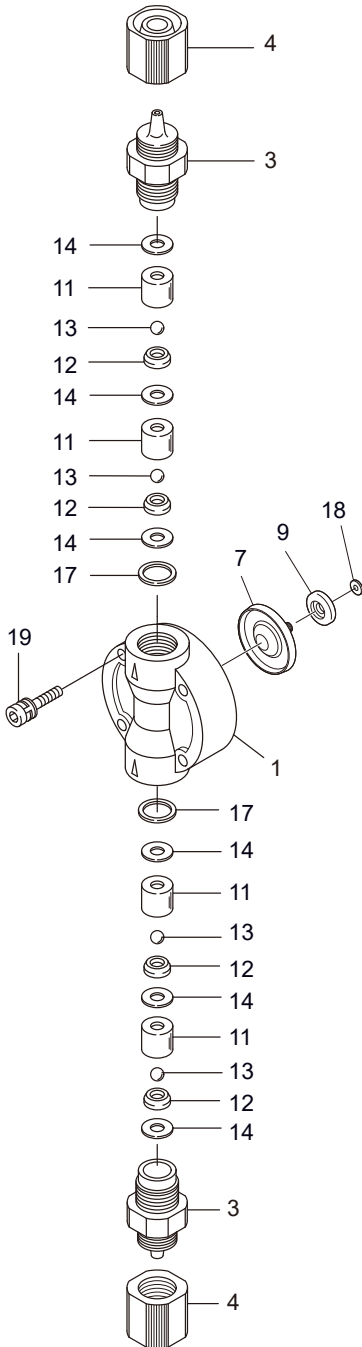

No.	Part names	# of parts
1	Pump head	1
3	Fitting	2
4	Fitting nut	2
7	Diaphragm	1
9	Retainer	1
11	Valve guide	4
12	Valve seat	4
13	Valve	4
14	Valve gasket	6
17	Gasket	2
18	Diaphragm spacer	*
19	Hex. socket head bolt [PW•SW]	4

\*The number of diaphragm spacers varies with pump model.

■ EHN-BN\_/-CN\_SH

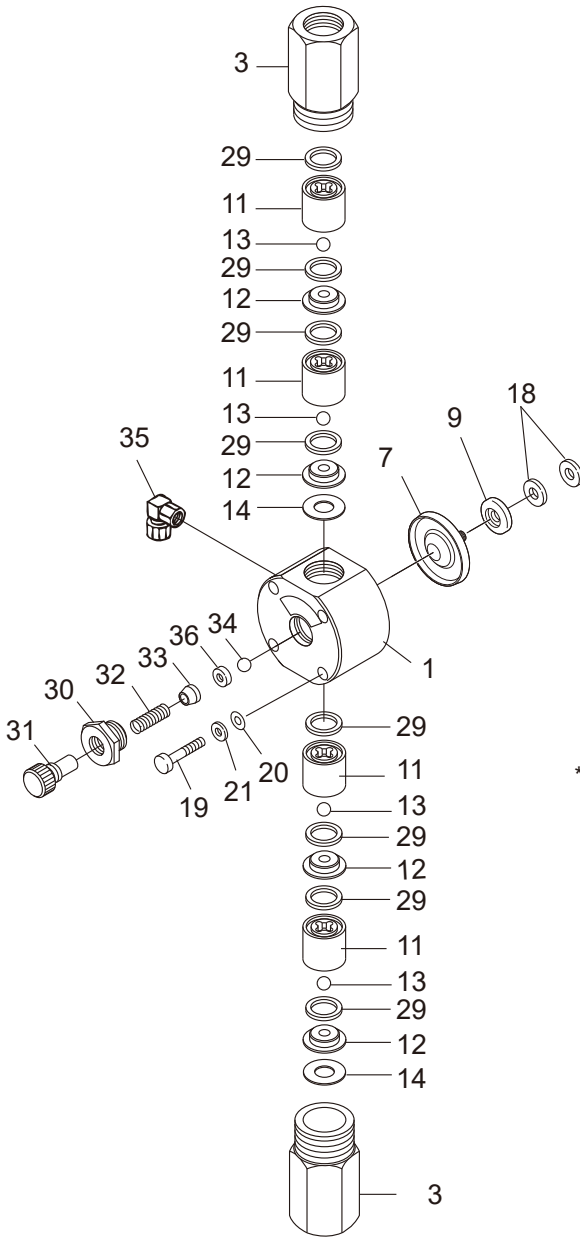

No.	Part names	# of parts
1	Pump head	1
3	Fitting	2
7	Diaphragm	1
9	Retainer	1
11	Valve guide	4
12	Valve seat	4
13	Valve	4
14	Valve gasket B	2
18	Diaphragm spacer	*
19	Hex. socket head bolt [PW•SW]	4
29	Valve gasket A	8
30	Seal nut	1
31	Adjusting screw	1
32	Spring	1
33	Seal ring	1
34	Valve	1
35	Tube connector	1
36	Spacer	1

\*The number of diaphragm spacers varies with pump model.

■ EHN-BN09VC

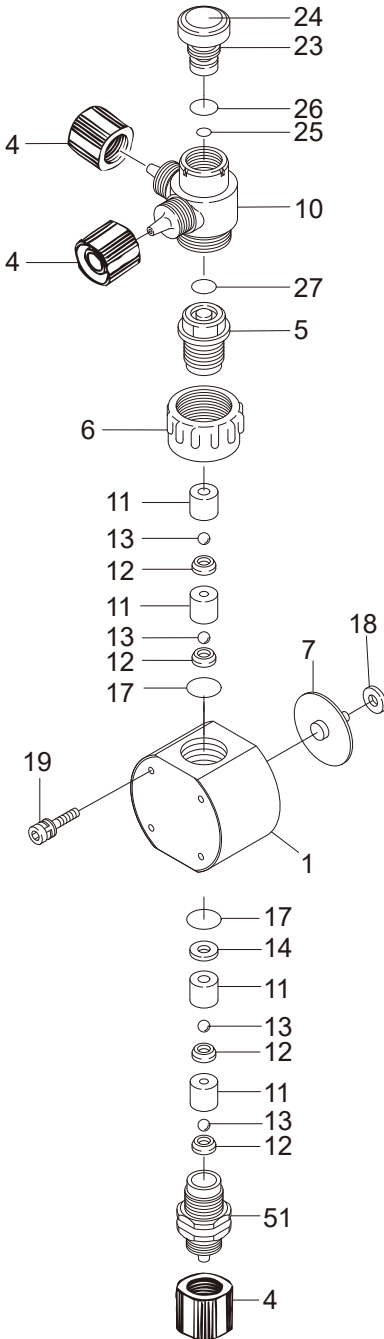

No.	Part names	# of parts
1	Pump head	1
4	Fitting nut	3
5	Air vent body B	1
6	Lock nut	1
7	Diaphragm unit	1
10	Air vent body A	1
11	Valve guide	4
12	Valve seat	4
13	Valve	4
14	Valve gasket	1
17	O ring	2
18	Diaphragm spacer	*
19	Hex. socket head bolt [PW•SW]	4
23	Adjusting screw	1
24	Name plate	1
25	O ring	1
26	O ring	1
27	O ring	1
51	Fitting	1

\*The number of diaphragm spacers varies with pump model.

■ EHN-CN31/-CN36 VS/PS MK-V

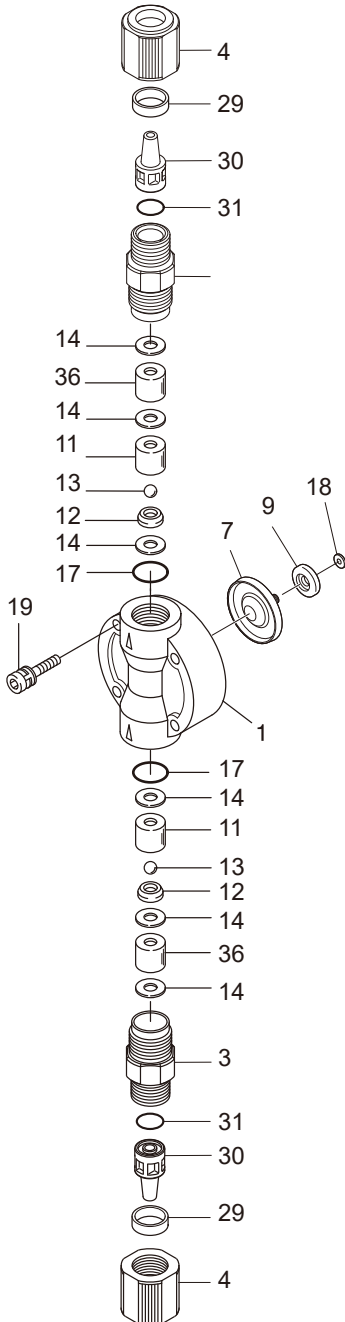

No.	Part names	# of parts
1	Pump head	1
3	Fitting	2
4	Fitting nut	2
7	Diaphragm	1
9	Retainer	1
11	Valve guide	2
12	Valve seat	2
13	Valve	2
14	Valve gasket	6
17	O ring	2
18	Diaphragm spacer	*
19	Hex. socket head bolt [PW•SW]	4
29	Hose stopper	2
30	Hose adaptor	2
31	O ring	2
36	Valve spacer	2

\*The number of diaphragm spacers varies with pump model.

## ■ EHN-BN\_/\_CN\_-NAE

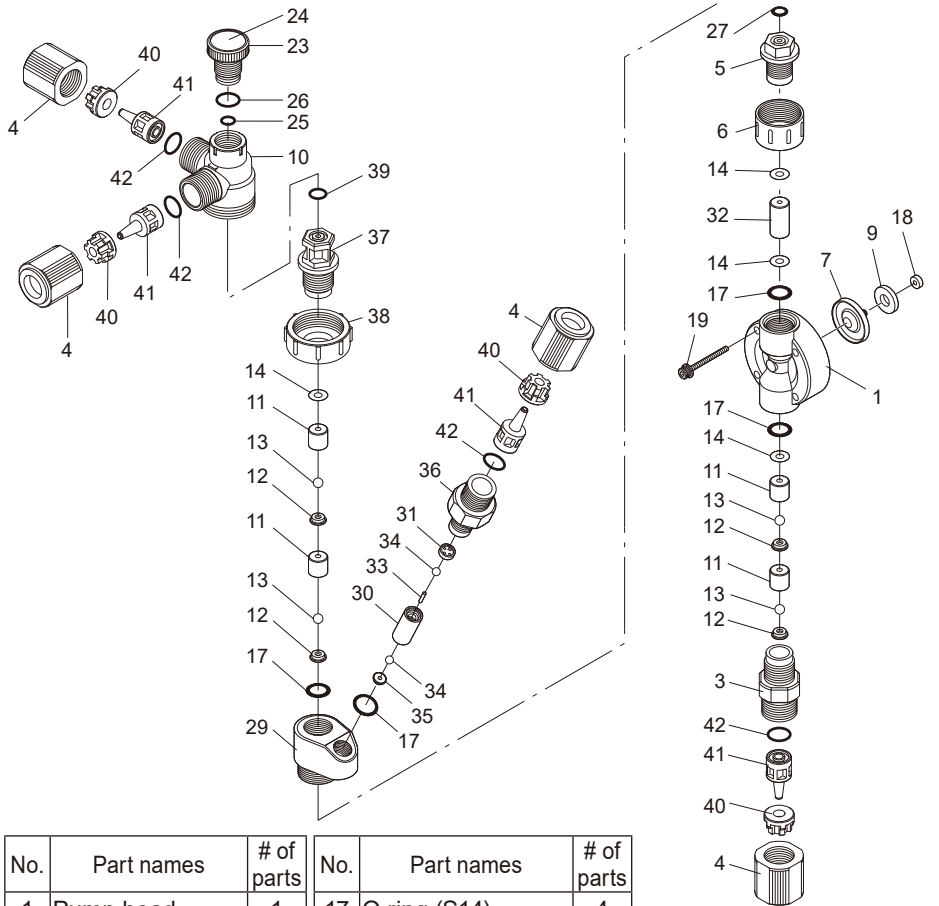

No.	Part names	# of parts	No.	Part names	# of parts
1	Pump head	1	17	O ring (S14)	4
3	Fitting	1	18	Diaphragm spacer	*
4	Fitting nut	4	19	Hex. socket cap bolt [PW-SW]	4
5	Air vent body B	1	23	Adjusting screw	1
6	Lock nut	1	24	Name plate	1
7	Diaphragm	1	25	O ring (P4)	1
9	Retainer	1	26	O ring (P10A)	1
10	Air vent body A	1	27	O ring (P7)	1
11	Valve guide	4	29	Fitting adaptor	1
12	Valve seat	4	30	Air vent valve guide A	1
13	Valve	4	31	Air vent valve guide B	1
14	Valve gasket	4	32	Spacer	1

No.	Part names	# of parts
33	Separate pin	1
34	Valve	2
35	Valve seat	1
36	Fitting	1
37	Air vent body B	1
38	Lock nut	1
39	O ring	1
40	Hose stopper	4
41	Hose adaptor	4
42	O ring	4

\*The number of diaphragm spacers varies with pump model.

## Check valve (VC/VS/PC/PS/PP)

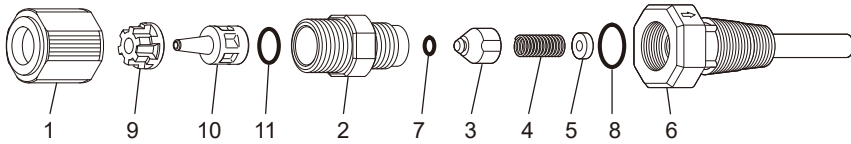

No.	Part names	# of parts
1	Fitting nut	1
2	Check valve body	1
3	Poppet valve	1
4	Spring	1
5	Spacer	1 (0)
6	Valve fitting A	1
7	O ring	1
8	O ring	1
9	Hose stopper	1
10	Hose adaptor	1
11	O ring	1

\*Tighten the check valve body to the valve fitting A by 2.94N·m.

\*No spacer is provided to the CAN-2VCL-M/-2VEL-M/-2VL-M/-2EL-M.

\*The shape of the hose stopper changes with the tube size. See page 26 for detail.

## Specifications/Outer dimensions

### Specifications

Information in this section is subject to change without notice.

#### ■ Pump unit

#### VC/VS/PC/PS/PP

Model code	Max. output capacity mL/min	Max. rated discharge pressure MPa	Stroke length mm (%)	Stroke rate spm	Tube size mm	Average current A	Average power cons. W	Weight kg
EHN-BN09-1	18	0.5	0.5-1.0 (50-100)	1 - 360	ø4×ø9	0.8	20	1.8
EHN-BN09-2					ø4×ø6			
EHN-BN11	38	1.0						
EHN-BN16	65	0.7						
EHN-BN21	100	0.4						
EHN-BN31	230	0.2			ø8×ø13/ ø9×ø12			
EHN-CN16	80	1.0	0.5-1.25 (40-100)		ø4×ø9/ ø4×ø6	1.2	24	2.9
EHN-CN21	130	0.7						
EHN-CN31	270	0.35						
EHN-CN36	450	0.2			ø8×ø13/ ø9×ø12			

#### PS-H (High compression type)

Model code	Max. output capacity mL/min	Max. rated discharge pressure MPa	Stroke length mm (%)	Stroke rate spm	Tube size mm	Average current A	Average power cons. W	Weight kg
EHN-BN11PS-H	30	1.5	0.5-1.0 (50-100)	1-360	ø4×ø9/ ø4×ø6	0.8	20	1.8
EHN-CN16PS-H	60	1.5	0.5-1.25 (40-100)			1.2	24	2.9

#### VS-V/PS-V (High viscosity type)

Model code	Max. output capacity mL/min	Max. rated discharge pressure MPa	Stroke length mm (%)	Stroke rate spm	Tube size mm	Average current A	Average power cons. W	Weight kg
EHN-CN31 VS-V/PS-V	220	0.35	0.5-1.25 (40-100)	1-300	ø8×ø13/ ø9×ø12	1.2	24	2.9
EHN-CN36 VS-V/PS-V	350	0.2						

## FC

Model code	Max. output capacity mL/min	Max. rated discharge pressure MPa	Stroke length mm (%)	Stroke rate spm	Tube size mm	Average current A	Average power cons. W	Weight kg
EHN-BN11	38	1.0	0.5 -1.0 (50 - 100)	1 - 360	ø4×ø6	0.8	20	1.8
EHN-BN21	100	0.4						
EHN-CN21	130	0.7	0.5 - 1.25 (40 - 100)		ø10×ø12	1.2	24	2.9
EHN-CN31	270	0.35						
EHN-CN36	410	0.2						

## SH

Model code	Max. output capacity mL/min	Max. rated discharge pressure MPa	Stroke length mm (%)	Stroke rate spm	Pipe size mm	Average current A	Average power cons. W	Weight kg
EHN-BN11	38	1.0	0.5 - 1.0 (50 - 100)	1 - 360	ø4×ø6	0.8	20	2.4
EHN-BN21	100	0.4						
EHN-CN21	130	0.7	0.5 - 1.25 (40 - 100)		ø10×ø12	1.2	24	4.1
EHN-CN31	270	0.35						
EHN-CN36	410	0.2						

## NAE

Model code	Max. output capacity mL/min	Max. rated discharge pressure MPa	Stroke length mm (%)	Stroke rate spm	Pipe size mm	Average current A	Average power cons. W	Weight kg
EHN-BN11	30	1.0	0.5 - 1.0 (50 - 100)	1 - 360	ø4×ø9/ ø4×ø6	0.8	20	1.8
EHN-BN16	55	0.7						
EHN-CN16	65	1.0	0.5 - 1.25 (40 - 100)			1.2	24	2.9
EHN-CN21	110	0.7						

\*Maximum output capacity is rated with clean water at ambient temperature at maximum discharge pressure (also, stroke length 100%, stroke rate 100% and rated voltage). Output may increase as pressure decreases. For the pump with the EHN-BN\_/\_CN\_/\_VS/PS-V, the maximum output capacity reduces as liquid viscosity increases.

\*Allowable room temperature: 0-40°C

\*Allowable liquid temperature: 0-40°C for the pumps with VC/VS wet ends  
(0-60°C for the PC/PS/PP/FC/SH wet ends)

\*The EHN-BN21/\_CN16 with PP wet ends are not available.

\*Allowable power voltage deviation: ±10% of the rated voltage

\*If you are to use a different tube size (ø4×ø6 or ø9×ø12) with a multi-tube connection, change stopper size accordingly.

\*The EHN-BN\_/\_CN\_/\_PS-H model with the 1/2 tube size code (which has ø4×ø9 inlet and ø4×ø6 outlet/air vent) is also available.

## ■ Control unit

Operation mode	Mode	Manual
	Mode selection	EXT (multiplier or divisor)
Stroke rate	Setting range	1-360spm (1-300 for the VS-V/PS-V models)
	spm setting	UP and DOWN keys
STOP function	M-OFF	The pump stops during contact input.
	M-ON	The pump runs during contact input.
	Input signal	Dry contact or open collector <sup>*1</sup>
EXT mode	Max spm	Manual speed
	Pump behaviour	n strokes per signal (multiplier) <sup>*2</sup> n signals per stroke (divisor) <sup>*3</sup> 1:1 operation with n=1
	Input signal	Dry contact or open collector <sup>*1</sup>
	Divisor/Multiplier range	1-999 (divisor or multiplier selection)
Monitors	LCD	4-digit LCD
	LED	Green LED×1 (blinks at each stroke)
Buffer	Non-volatile memory	
Power voltage <sup>*4</sup>	100-240VAC 50/60Hz	

\*1 The maximum applied voltage from the EHN-R to an external contact is 12V with 5mA. The minimum application load of the relay or switch should be 5mA or below.

\*2 In the operation with the multiplier, external signals that have not been processed are stored for up to 64535 strokes.

\*3 In the operation with the divisor, external signals entered to run the pump over the MAN speed are cancelled.

\*4 Observe the allowable power voltage range of 90-264VAC. Or failure may result.

## ■ Power cable

Conduction section area	0.75 [mm <sup>2</sup> ] duplex cable
Length	1500 [mm]
Cable type/standard	VCTFK
Terminal end	Spade terminal (V1.25-YS4A or equivalent)

## ■ Pump colour

Blue	Munsell colour system 7.5PB 3/8
Red	Munsell colour system 5R 3/10

## ■ Check valve

Model code	Set pressure MPa	Connection size mm	Wet ends	Applicable pump models	Wet end codes	
CAN-1VC-M	0.17	ø4×ø9/ ø4×ø6	PVC	EHN-BN11/-BN16/-BN21 EHN-CN16/-CN21	VC	
CAN-1VE-M					VS	
CAN-2VC-M		ø8×ø13/ ø9×ø12		EHN-CN31	VC	
CAN-2VE-M					VS	
CAN-2VCL-M	0.05	ø8×ø13/ ø9×ø12		EHN-BN31 EHN-CN36	VC	
CAN-2VEL-M					VS	
CAN-1V-M	0.17		ø4×ø9/ ø4×ø6	GFRPP	EHN-BN11/-BN16/-BN21 EHN-CN16/-CN21	PC/PP
CAN-1E-M						PS
CAN-2V-M			ø8×ø13/ ø9×ø12		EHN-CN31	PC/PP
CAN-2E-M						PS
CAN-2VL-M	0.05	ø8×ø13/ ø9×ø12	EHN-BN31 EHN-CN36		PC/PP	
CAN-2EL-M					PS	
CS-1E-2	0.12		ø4×ø6	SUS304	EHN-BN11 -H EHN-CN16 -H	PS
CA-1VCLL-4×6	0.03					ø4×ø9
CA-1VCLL-4						
CS-1S	0.2		Rc ¼	SUS304	EHN-BN11/-BN21 EHN-CN21/-CN31	SH
CS-1SL	0.05	EHN-CN36				
BVC-1TV-4H	0.2	ø4×ø6	PVDF	EHN-BN11/-BN21 EHN-CN21	FC	
BVC-1TV-10H		0.1				ø10×ø12
	EHN-CN36					

\*If you are to use a different tube size (ø4×ø6 or ø9×ø12) with a multi-tube connection, change stopper size accordingly.

## Outer dimensions

### ■ EHN-BN11/-BN16/-BN21 VC/VS/PC/PS/PP M

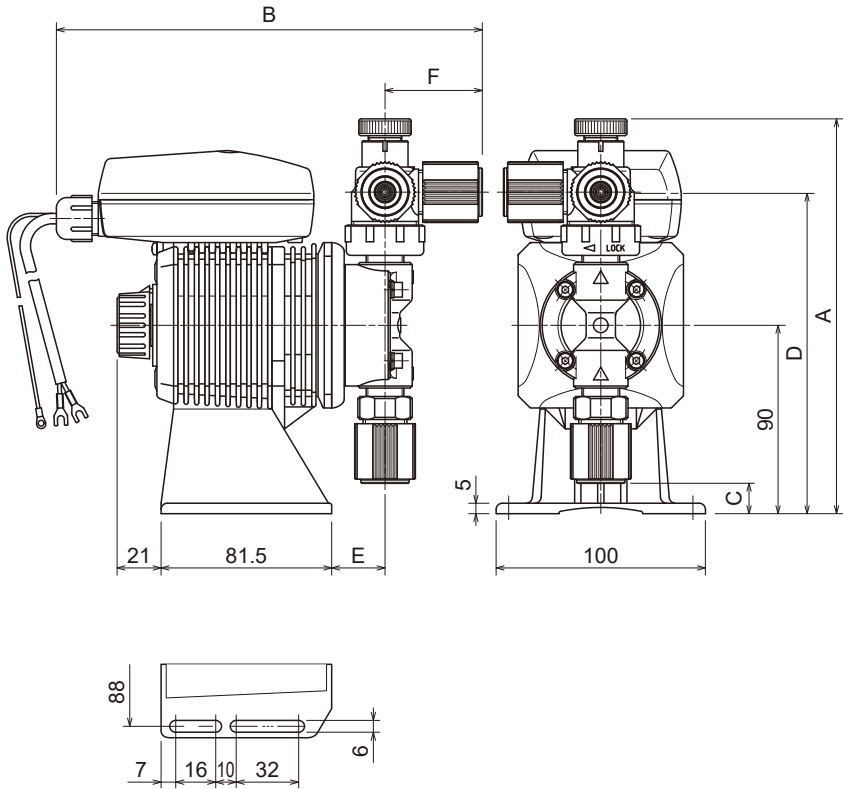

Model		A	B	C	D	E	F	
EHN-BN	11/16/21	VC/VS/PC/PS	189	204	14	154	26	47
	11/16	PP	190			155		

■ EHN-BN31 VC/VS/PC/PS/PP M

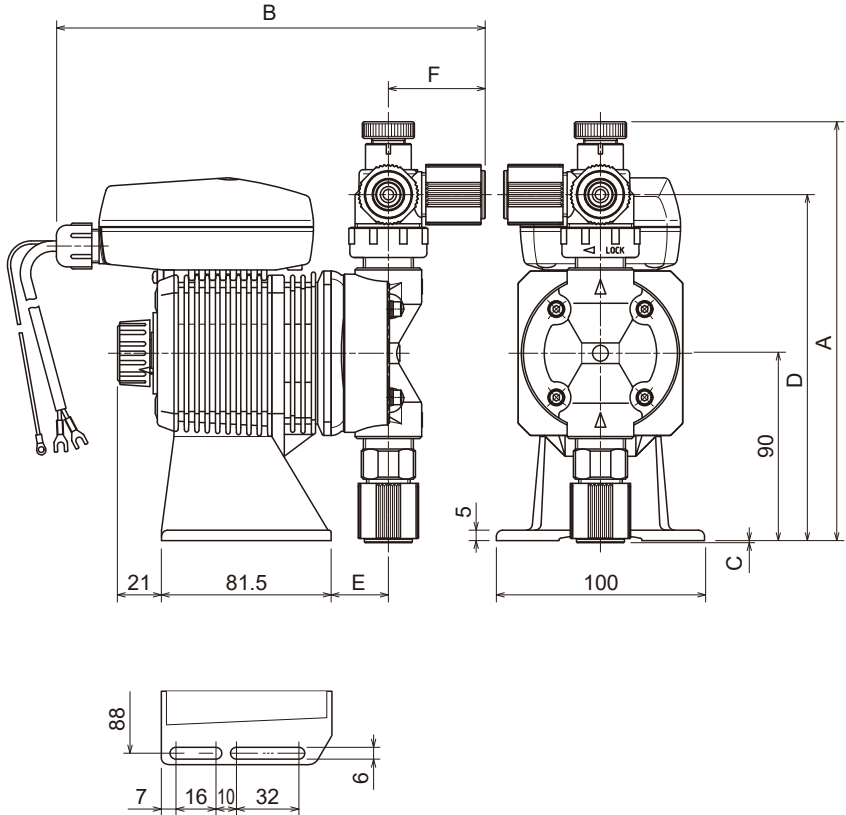

	Model	A	B	C	D	E	F
EHN-BN31	VC/VS/PC/PS	201	206	1	166	28	47
	PP	202			167		

■ EHN-BN31 VC/VS MK

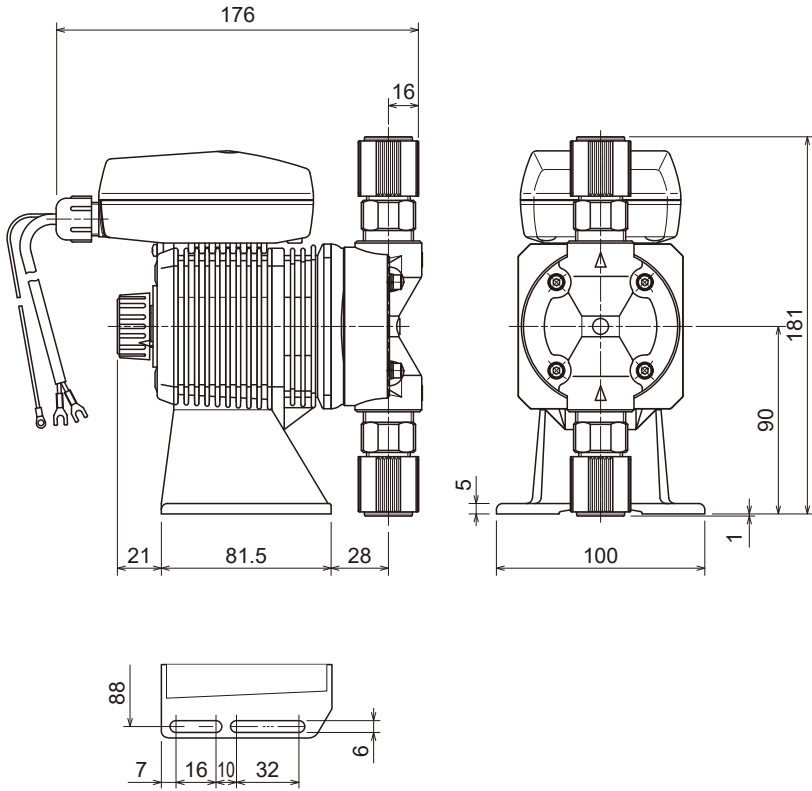

■ EHN-BN11/-BN21 FC

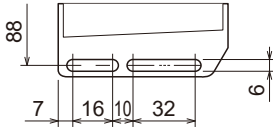
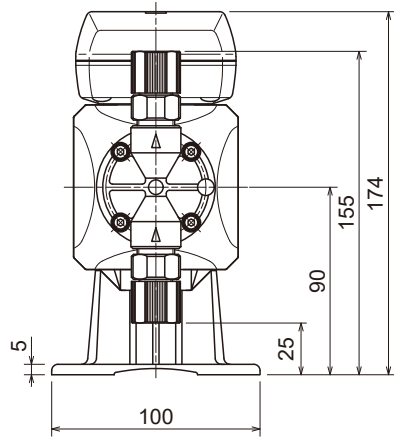
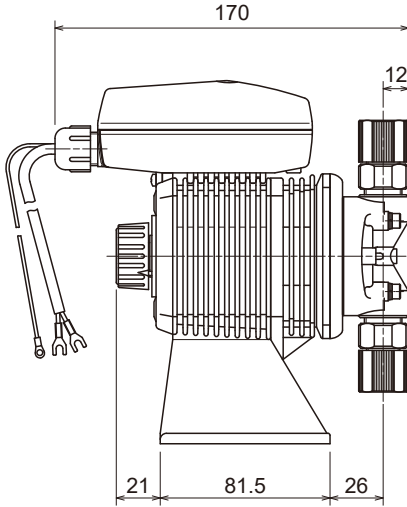

■ EHN-BN11/-BN21 SH

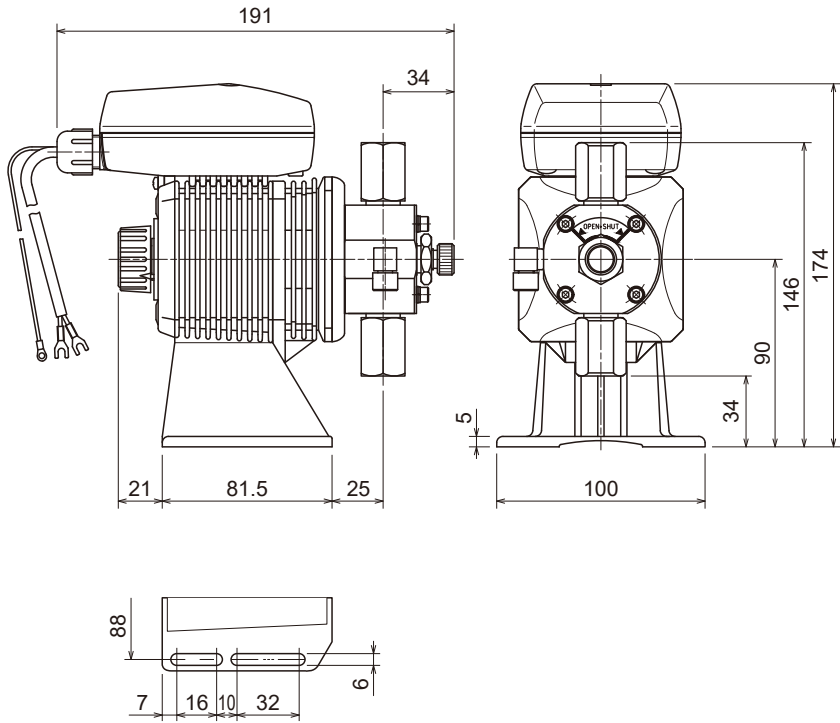

■ EHN-BN09VC

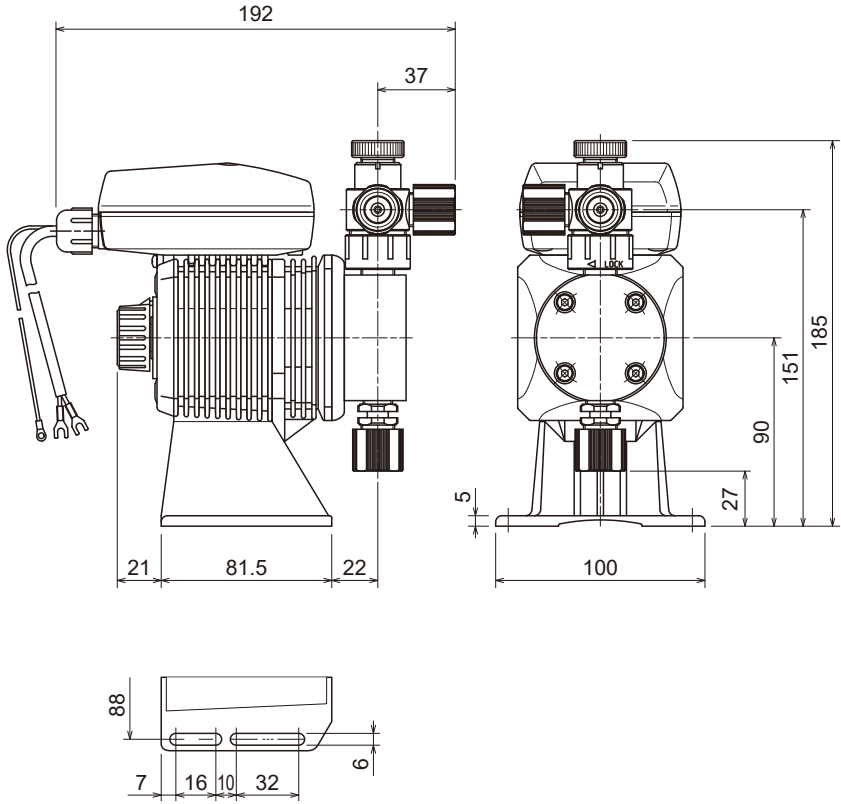

■ EHN-BN11/-BN16 VC/VS M-NAE

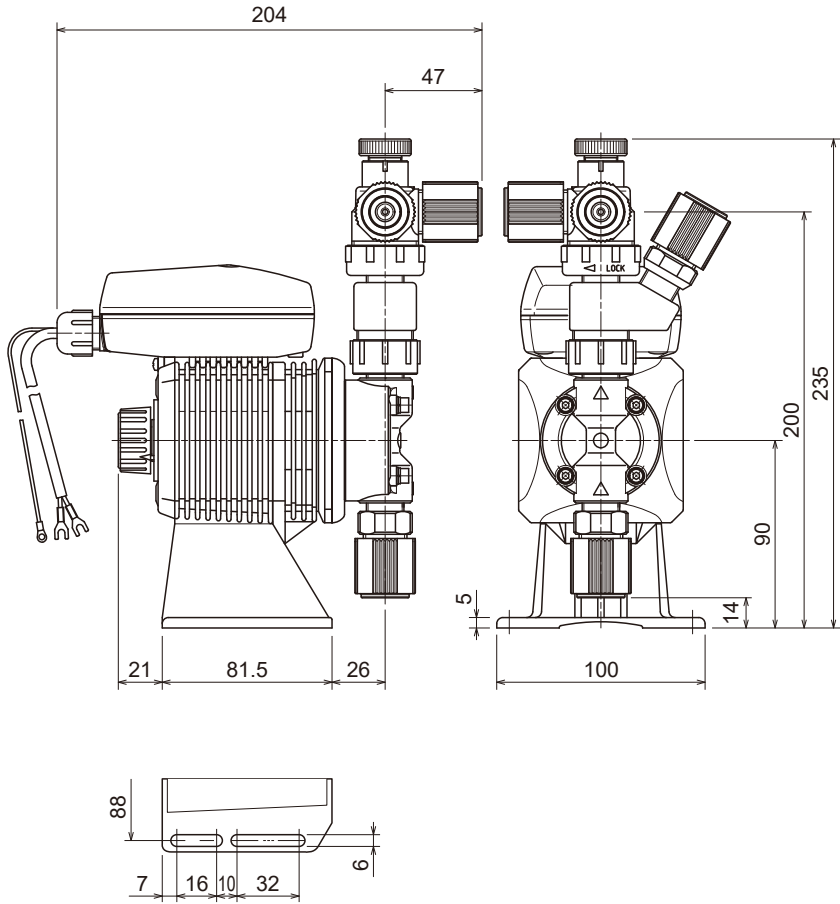

■ EHN-CN16/-CN21/-CN31/-CN36 VC/VS/PC/PS/PP M

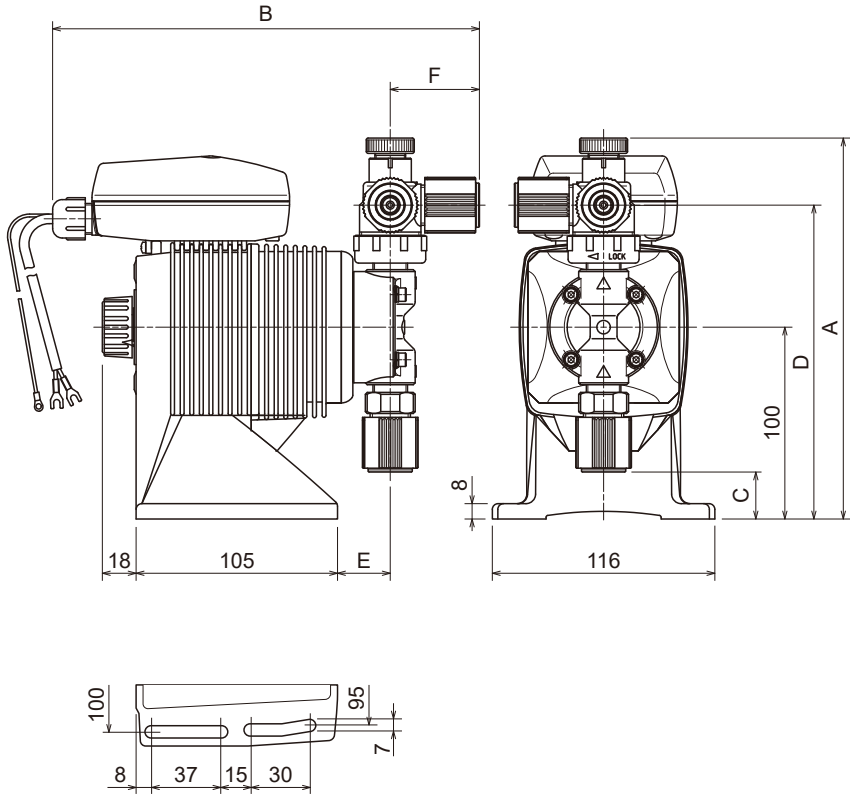

Model		A	B	C	D	E	F
EHN-CN	16/21	VC/VS/PC/PS	199	223	24	164	47
	21	PP	200	222		165	
	31/36	VC/VS/PC/PS	211	224	10	176	
	31	PP	212		8	177	
	36	PP	211		9	176	

■ EHN-CN31/-CN36 VC/VS MK

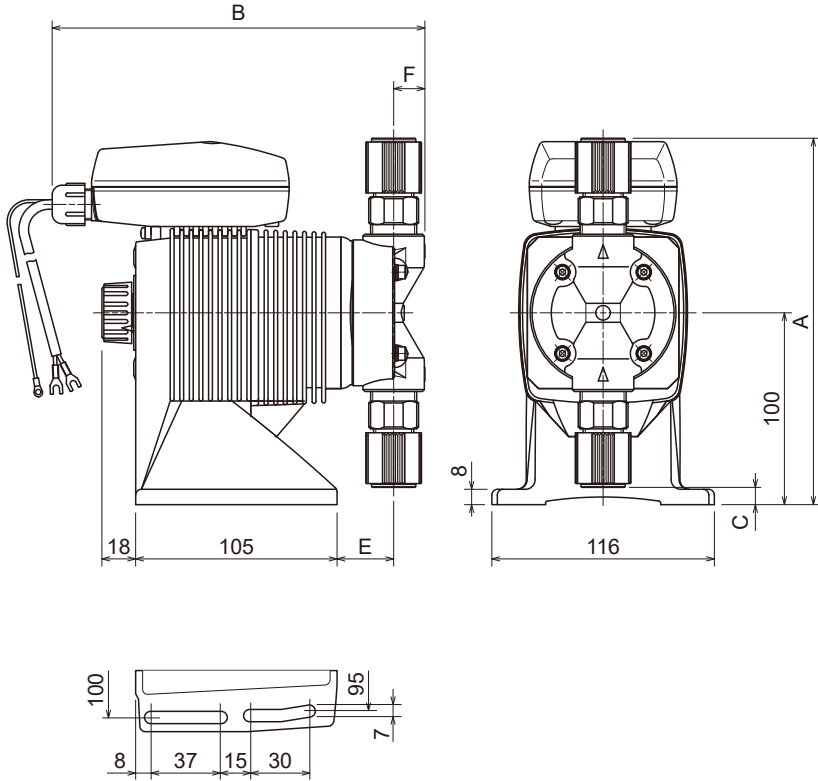

Model		A	B	C	D	E	F
EHN-CN	31	191	194	9	-	29	16
	36	190		10			

■ EHN-CN21/-CN31/-CN36 FC

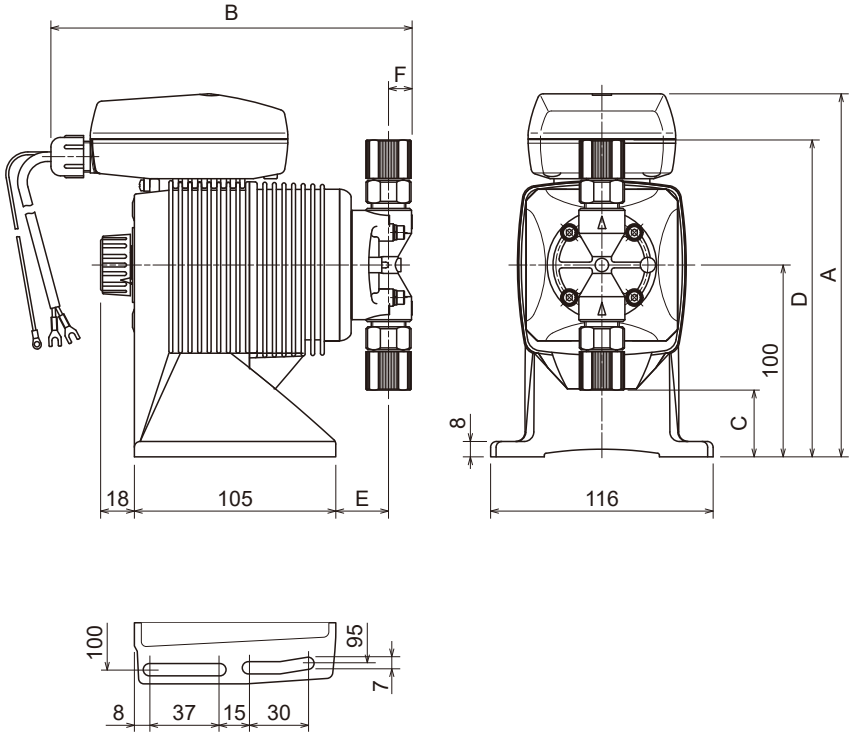

Model		A	B	C	D	E	F
EHN-CN	21	189	189	35	165	27	12
	31		194	18.5			
	36		193	18	182	29	16

■ EHN-CN21/-CN31/-CN36 SH

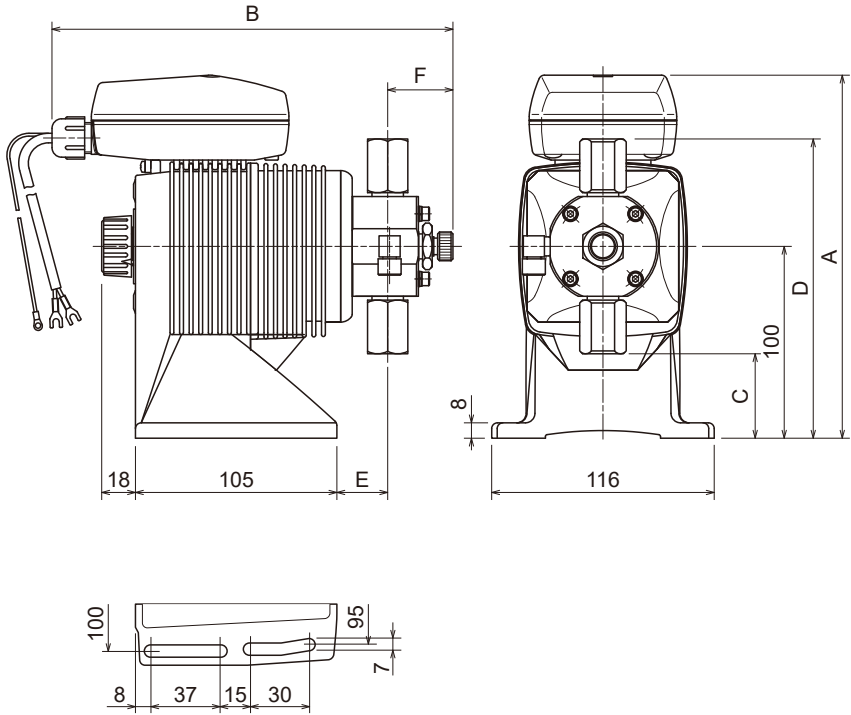

Model		A	B	C	D	E	F
EHN-CN	21	189	209	44	156	26	34
	31		212	34	166	28	35
	36		211	31	169		34

■ EHN-CN16/-CN21 VC/VS M-NAE

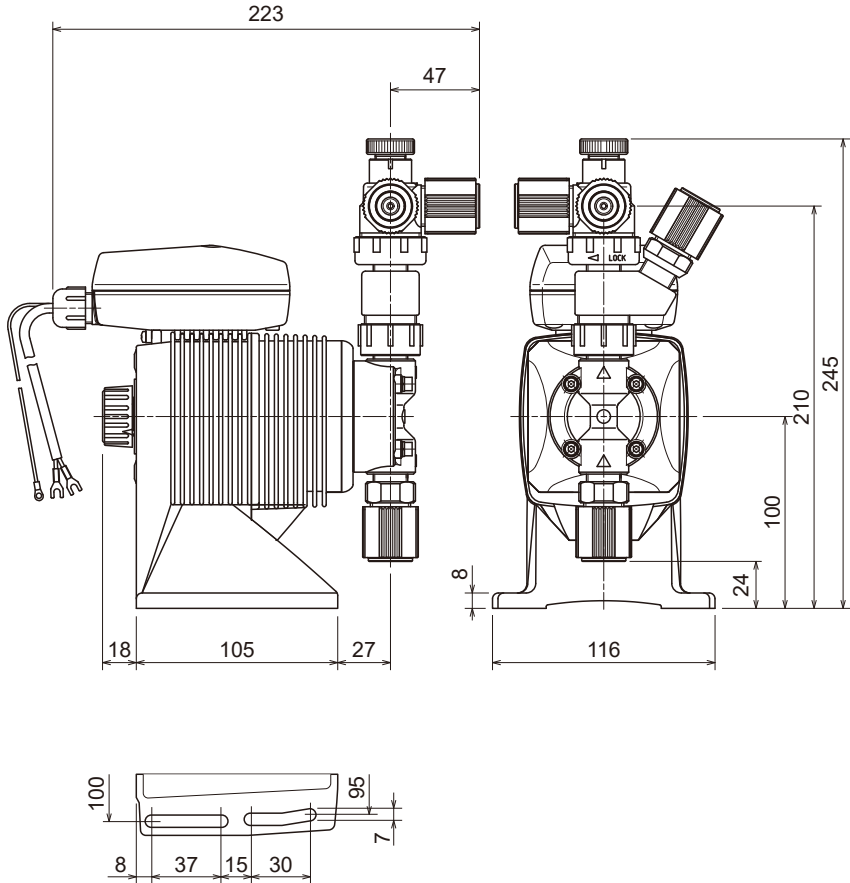







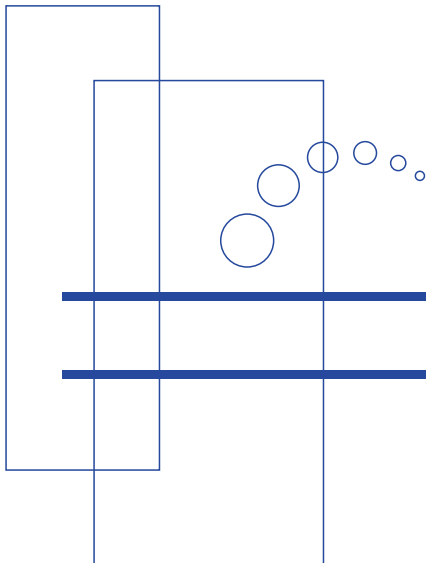

<https://www.iwakupumps.jp>

IWAKI CO.,LTD. 6-6 Kanda-Sudacho 2-chome Chiyoda-ku Tokyo 101-8558 Japan  
TEL: +81 3 3254 2935 FAX: +81 3 3252 8892

**European Headquarter** / IWAKI Europe GmbH  
TEL: +49 2154 9254 0 FAX: +49 2154 9254 48

**Germany** / IWAKI Europe GmbH  
TEL: +49 2154 9254 50 FAX: +49 2154 9254 55

**The Netherlands** / IWAKI Europe GmbH (Netherlands Branch)  
TEL: +31 74 2420011 FAX: +49 2154 9254 48

**Italy** / IWAKI Europe GmbH (Italy Branch)  
TEL: +39 0445 561219 FAX: +39 0445 569088

**Spain** / IWAKI Europe GmbH (Spain Branch)  
TEL/FAX: +34 934 741 638

**Poland** / IWAKI Europe GmbH (East Europe Branch)  
TEL: +48 12 347 0755 FAX: +48 12 347 0900

**Denmark** / IWAKI Nordic A/S  
TEL: +45 48 242345

**Finland** / IWAKI Suomi Oy  
TEL: +358 10 201 0490

**Norway** / IWAKI Norge AS  
TEL: +47 23 38 49 00

**Sweden** / IWAKI Sverige AB  
TEL: +46 8 511 72900

**Belgium** / IWAKI Belgium N.V.  
TEL: +32 13 670200 FAX: +32 13 672030

**France** / IWAKI France S.A.  
TEL: +33 1 69 63 33 70 FAX: +33 1 64 49 92 73

**U.S.A.** / IWAKI America Inc.  
TEL: +1 508 429 1440 FAX: +1 508 429 1386

**Brazil** / IWAKI Do Brasil Comercio De Bombas Hidraulicas LTDA.  
TEL/FAX: +55 19 3244 5900

**China** (Shanghai) / IWAKI Pumps (Shanghai) Co., Ltd.  
TEL: +86 21 6272 7502 FAX: +86 21 6272 6929

**China** (Hong Kong) / IWAKI Pumps Co., Ltd.  
TEL: +852 2607 1168 FAX: +852 2607 1000

**China** (Guangzhou) / GFTZ IWAKI Engineering & Trading Co., Ltd.  
TEL: +86 20 84350603 FAX: +86 20 84359181

**China** (Shenzhen) / IWAKI Pumps (Shenzhen) Co., Ltd.  
TEL: +86 0755 8656 3696

**Singapore** / IWAKI Singapore Pte Ltd.  
TEL: +65 6316 2028 FAX: +65 6316 3221

**Indonesia** / IWAKI Singapore Pte Ltd. (Indonesia Office)  
TEL: +62 21 6906606 FAX: +62 21 6906612

**Malaysia** / IWAKIIm SDN. BHD.  
TEL: +60 3 7803 8807 FAX: +60 3 7803 4800

**Korea** / IWAKI Korea Co., Ltd.  
TEL: +82 2 6238 4800 FAX: +82 2 6238 4801

**Taiwan** / IWAKI Pumps Taiwan Co., Ltd.  
TEL: +886 2 8227 6900 FAX: +886 2 8227 6818

**Thailand** / IWAKI (Thailand) Co., Ltd.  
TEL: +66 2 322 2471 FAX: +66 2 322 2477

**Australia** / IWAKI Pumps Australia Pty Ltd.  
TEL: +61 2 9899 2411 FAX: +61 2 9899 2421