

IWAKI Magnetic Drive Pump

MDW Series

Instruction Manual

 Read this manual before use of product

Thank you for selecting an Iwaki MDW Magnetic Drive Pump. This instruction manual deals with "*Safety instructions*", "*Outline*", "*Installation*", "*Operation*" and "*Maintenance*" sections. Please read through this manual carefully to ensure the optimum performance, safety and service of your pump.

Contents

Safety instructions	1
<i>Outline</i>	
1. Unpacking & Inspection	7
2. Product outline	7
3. Model code	8
4. Overview	9
5. Dimensions	11
6. Precautions for use	14
<i>Installation</i>	
1. Before installation	18
2. Pipework	19
3. Wiring	22
<i>Operation</i>	
1. Before operation	25
2. Operation	26
3. Shutdown	27
<i>Maintenance</i>	
1. Troubleshooting	29
2. Maintenance & Inspection	30
3. Spare & Wear parts	35
4. Assembly & Disassembly	37



This instruction manual should be kept on hand by the end user for quick reference.

Contact us or your nearest dealer if you have any questions.

Safety instructions

For the Safe and Correct Handling of the Pump

- "Safety Instruction" section deals with important details about handling of the product. Before use, read this section carefully for the prevention of personal injury or property damage.
- Observe the instructions accompanied with "WARNING" or "CAUTION" in this manual. These instructions are very important for protecting users from dangerous situations.
- The symbols on this instruction manual have the following meanings:

 WARNING	Nonobservance or misapplication of “Warning” sections could lead to a serious accident which may result in death.
 CAUTION	Nonobservance or misapplication of “Caution” sections could lead to a personal injury or property damage.

Types of Symbols



Indicates that “Warning” or “Caution” must be exercised. Inside this triangle, a concrete and practical image provided as a warning or caution message is depicted.



Indicates a prohibited action or procedure. Inside or near this circle, a concrete and practical image of the activity to be avoided is depicted.



Indicates an important action or procedure which must be performed or carried out without fail. Failure to follow the instructions herein can lead to malfunction or damage to the pump.

Export Restrictions

Technical information contained in this instruction manual might be treated as controlled technology in your countries, due to agreements in international regime for export control. Please be reminded that export license/permission could be required when this manual is provided, due to export control regulations of your country.

Safety instructions

WARNING

- **Access limitation**

The magnet drive pump has a pair of strong magnets (the magnet capsule unit and drive magnet). The strong magnet field could adversely affect the persons who are assisted by electronic devices such as the pacemaker.



- **Do not run pump dry**

Do not run pump dry (operation without priming water or with a suction valve closed). Internal parts are excessively worn by friction heat and fatal pump damage results.



- **Do not close the suction valve during operation**

Friction heat may damage internal parts.



- **Drain liquid before disassembly of the pump or storage**

Solution in the pump unit and the discharge line may be under pressure. Release the pressure from the pump/piping to avoid solution spray.



- **Suspend operation immediately**

If you notice leakage of liquid, suspend operation immediately and inspect/solve problems.



- **Turn off power before service**

Risk of electrical shock. Be sure to turn off power to stop the pump and related devices before service is performed.



- **Grounding**

Risk of electric shock! Always properly ground the pump. Conform to local electric codes.



- **Install a GFCI (earth leakage breaker)**

An electrical failure of the pump may adversely affect other devices on the same line. Purchase and install an earth leakage breaker separately.



- **Use specified power only**

Do not apply power other than that specified on the nameplate. Otherwise, failure or fire may result. Ensure the pump is properly grounded.



Safety instructions

WARNING

- **Wear protective clothing**

Always wear protective clothing such as an eye protection, chemical resistant gloves, a mask and a face shield during disassembly, assembly or maintenance work. The specific solution will dictate the degree of protection. Refer to SDS precautions from the solution supplier.



- **Do not modify the pump**

Alterations to the pump carries a high degree of risk. It is not the manufacturer's responsibility for any failure or injury resulting from alterations to the pump.



- **Daily inspection and maintenance**

Daily inspection and maintenance are required for the prevention of chemical spray or leakage when handling:

- Explosive or flammable liquid,
- Corrosive liquid, or
- Harmful liquid.



- **Use an overhead crane or any other proper transporting machine**

Two or more operators may be needed for ensuring safe transport depending on the pump size and weight.



- **Use the eye bolt or lifting holes**

Use the eye bolt when lifting the pump only. If the pump and the motor are mounted on the baseplate, use lifting holes on the baseplate.



- **Use strong ropes (chains) for lifting up the pump**

Keep away from the pump while it is lifted up for installation. Serious injury may result if lifting ropes (chains) break. Observe the working load limit of the ropes (chains).



- **Do not touch a rotating part**

A pump shaft and a motor shaft are coupled outside (coupling type). Be sure to cover the bare coupling in order to reduce the risk of personal injury which may occur as coming in contact with the coupling in operation.



- **Ventilation**

Fumes or vapours can be hazardous with certain solutions. Ensure proper ventilation at the operation site.



Safety instructions

CAUTION

• **Qualified personnel only**

The pump should be handled or operated by qualified personnel with a full understanding of the pump. Any person not familiar with the product should not take part in the operation or management of the pump.



• **Commissioning**

Friction heat builds up and damages the internal parts. Break in the pump to expel gas from the pump and piping, especially when handling liquids that generate gas bubbles (sodium hypochlorite or hydrazine solution).



• **Check for loose bolts before operation**

Retighten the split plate mounting bolts, the rear casing support mounting bolts and the air vent-/drain-plate mounting bolts by the specified torque.



• **Pay attention to magnet force**

The pair of strong magnets in the pump and its magnetic force may adversely affect magnetic disks/cards or wrist watches. Do not bring them close to the pump.



Prohibited

• **Do not catch the finger**

Magnetic force of the pump is powerful. When taking apart or putting together the pump, take measures not to catch the finger in the bracket. Also, keep the drive magnet and the driven magnet free from iron debris/powder.



• **Do not use the pump in any condition other than its intended purpose**

The use of the pump in any conditions other than those clearly specified may result in failure or injury. Use this product in specified conditions only.



Prohibited

• **Static electricity**

When low electric conductivity liquids such as ultra-pure water and fluor inactive liquid (e.g. Fluorinert™) are handled, static electricity may generate in the pump and may cause static discharge. Take countermeasures to remove static electricity.



• **Do not install/store the pump:**

- Where ambient temperature can exceed 0-40 °C.
- Where ambient humidity can exceed 35-85 %RH.
- In a flammable/explosive/corrosive atmosphere.
- In wind & rain.
- Under mechanical vibrations.



Prohibited

Safety instructions

CAUTION

- **Spill precautions**

Ensure protection and containment of solution in the event of plumbing or pump damage (secondary containment).



- **When unpacking a wooden box**

Be careful not to be injured by nails or wood debris.



- **Disposal of a used pump**

Remove a chemical and flush it out before the pump is disconnected from piping. Dispose of any used or damaged pump and liquid in accordance with local rules and regulations. If necessary, consult a licensed industrial waste disposal company.



- **When transferring hazardous liquid**

Install/operate the pump in according with local rules and regulations.



Caution

- **Do not burn the pump (incombustible)**

Fluoroplastic parts are used in this product and generate harmful gas when thrown into fire.



- **Do not operate the pump in a flammable atmosphere**

Do not place explosive or flammable material near the pump.



Fire ban

Outline

<i>1. Unpacking & Inspection</i>	<i>7</i>
<i>2. Product outline.....</i>	<i>7</i>
<i>3. Model code</i>	<i>8</i>
<i>4. Overview.....</i>	<i>9</i>
<i>5. Dimensions.....</i>	<i>11</i>
<i>6. Precautions for use.....</i>	<i>14</i>

Outline

1. Unpacking & Inspection

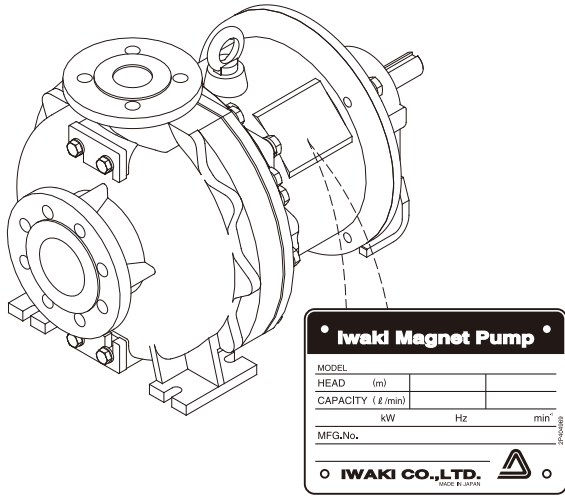

Open the package and check that the product conforms to your order. If any problem or inconsistency is found, immediately contact your distributor.

1. Check the nameplate to see if the information such as model codes, discharge capacity, discharge pressure and stroke rate are as ordered.
2. Check if attachments are complete. Also, check optional products.

<Attachment list>

- a. Guide bolts (Two each)
- b. Hexagon bolts (M12×130: Two each)

<Optional product list>

Spare parts or peripheral devices such as the dry run protector.

3. Check for transit damage.
4. Check for loose bolts.

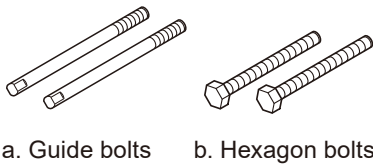

a. Guide bolts b. Hexagon bolts

2. Product outline

The MDW series is a large-scale process magnet pump which has fluoroplastic and fine ceramic wet ends and is capable of sending most chemicals including strong acid and alkaline.

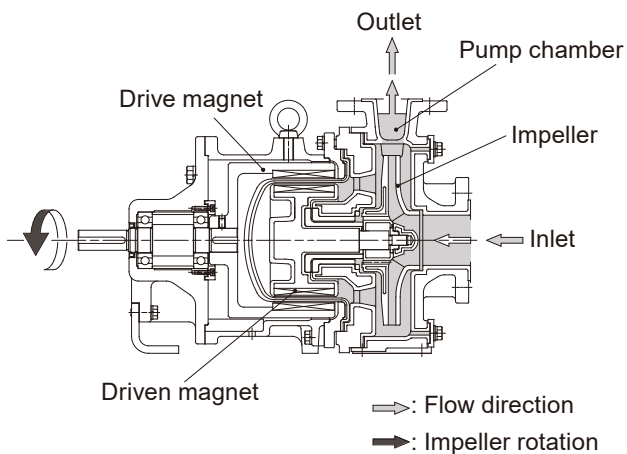

■ Principle of operation

The long coupled motor unit, the flange motor or the foot mounted flange motor rotates the driven magnet in the pump unit.

An impeller rotates in the pump chamber along with the driven magnet to transfer liquid from the inlet to outlet.

Outline

3. Model code

MDW 50 - 260 P K Z C 450 J - E 2
a b c d e f g h i j k

a. Series name

b. Pump bore size & Motor output

Model	Pump bore size (Inlet × Outlet)	Motor output (kW)	
		2P	4P
MDW50	80A × 50A	22/30/37/45/55/75	11/15/18.5/22/37
MDW80	125A × 80A	37/45/55/75	
MDW100	125A × 100A		

c. Impeller nominal diameter

170 - 260

d. Wet end materials

E: ETFE + PFA P: PFA

e. Bearing/Thrust/Sleeve

K: SiC/SiC/SiC

f. O ring material

Z: Kalrez® V: FKM E: EPDM

g. Motor unit

C: Foot mounted motor (coupling type)

F: Flange motor

: Foot mounted flange motor (flange type)

h. Motor output

110: 11 kW 150: 15 kW 185: 18.5 kW 220: 22 kW 300: 30 kW
 370: 37 kW 450: 45 kW 550: 55 kW 750: 75 kW

i. Flange & Motor standard

I: ISO flange/ IEC motor

J: JIS flange/ JIS motor

A: ANSI flange/ JIS motor

j. Drain

Code	Drain port/Air vent port	Delivery state	Standard/Special version
A	No drain port provided	A pump on a base	Standard
S	No air vent port provided		Special version
D	A drain port provided		Standard
X	An air vent port provided		Special version
B	No drain port provided	Pump unit • No base • No coupling* • No coupling cover*	Standard
Y	No air vent port provided		Special version
E	A drain port provided		Standard
Z	An air vent port provided		Special version

*Coupling type only

k. Motor pole

2: Two

4: Four

Outline

4. Overview

The illustration below shows pumps on the base.

■ Foot mounted motor (coupling)

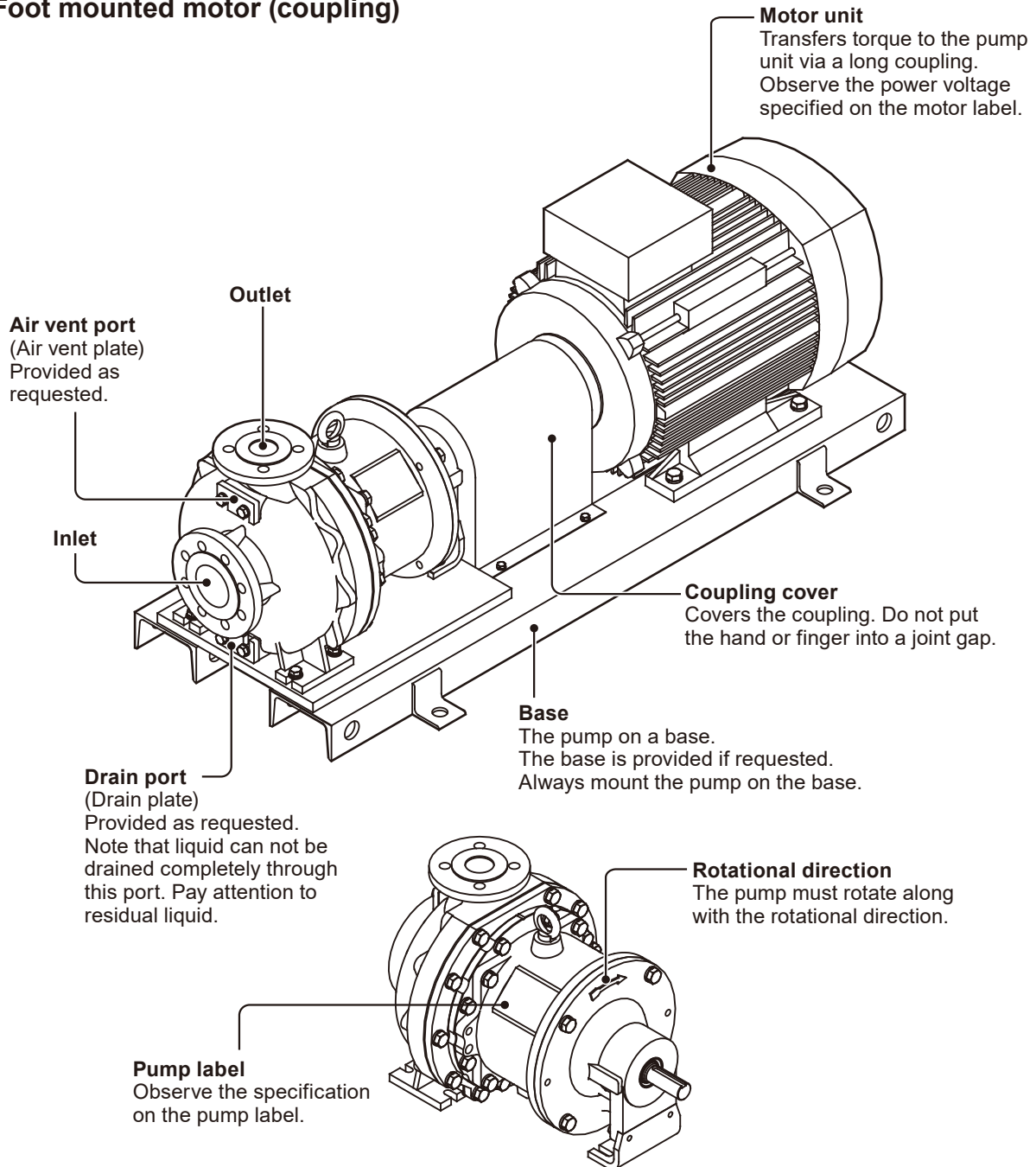

⚠ CAUTION

Do not clean the pump or nameplate with a solvent such as benzene or thinner. This may discolour the pump or erase printing. Use a dry or damp cloth or a neutral detergent.

⚠ CAUTION

Turn off main power before cleaning. Be careful not to wet the motor unit (terminal box and fan cover) and wiring. Otherwise electrical shock or short circuit may result.

Outline

■ Flange motor

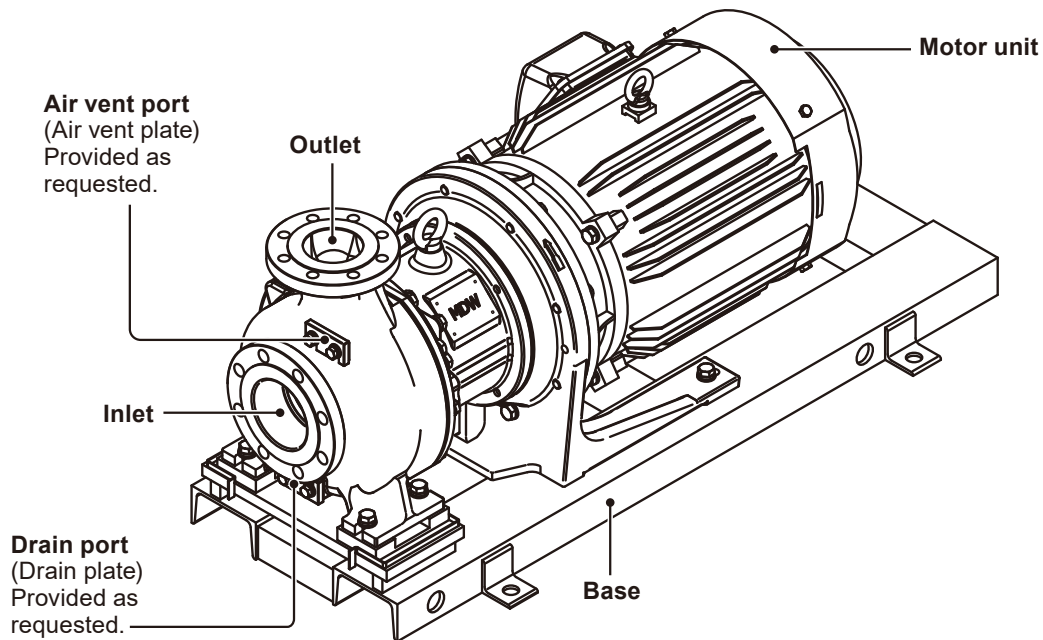

■ Foot mounted flange motor

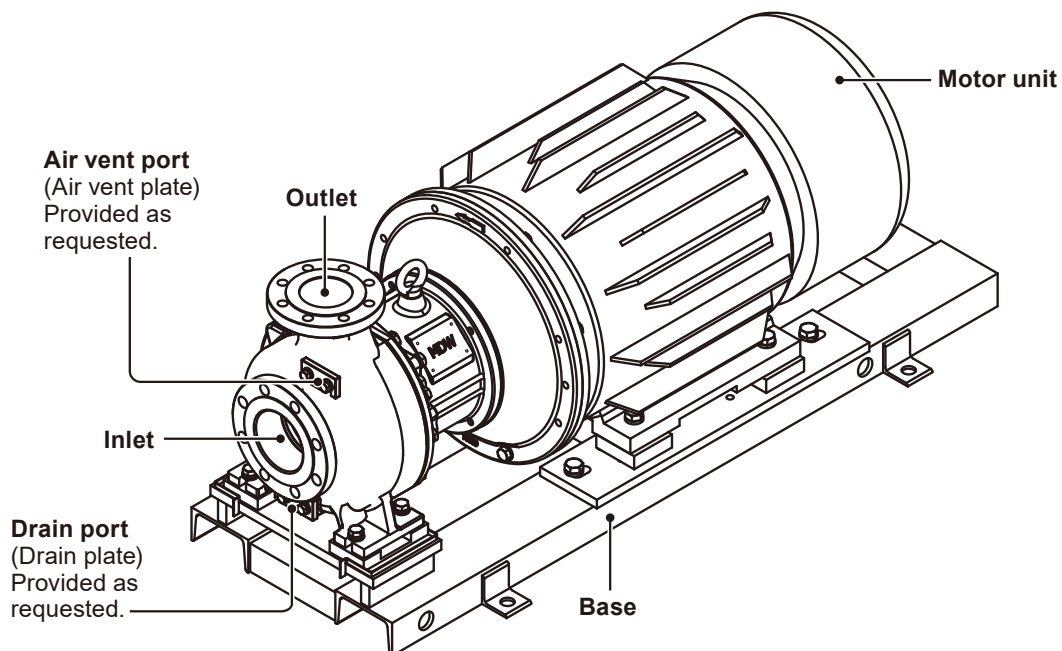

⚠ CAUTION

Do not clean the pump or nameplate with a solvent such as benzene or thinner. This may discolour the pump or erase printing. Use a dry or damp cloth or a neutral detergent.

⚠ CAUTION

Turn off main power before cleaning. Be careful not to wet the motor unit (terminal box and fan cover) and wiring. Otherwise electrical shock or short circuit may result.

Outline

5. Dimensions

See an approved drawing for part names and structure.

■ Foot mounted motor (coupling)

See the approval drawing for detail dimension.

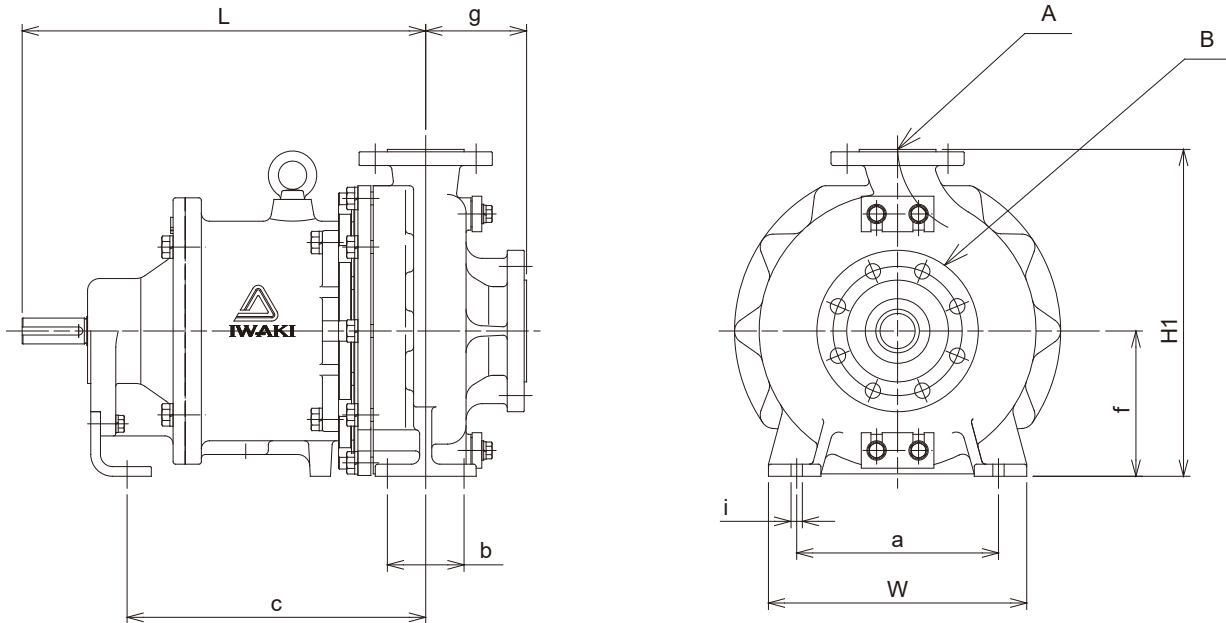

Unit: mm

Model	W	H1	L	a	b	c	f	g	i	A	B	Weight (kg)*
MDW50	320	405	500	250	95	370	180	125	14	50	80	155
MDW80	400	505		315	120		225		18	80	125	170
MDW100	360	480		280			200		100			

*Pump weight without motor

Outline

■ Flange motor

See the approval drawing for detail dimension.

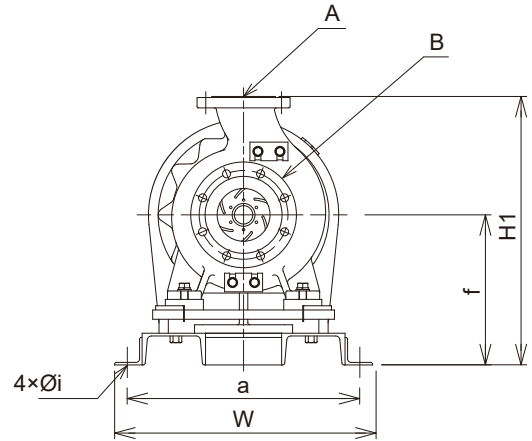
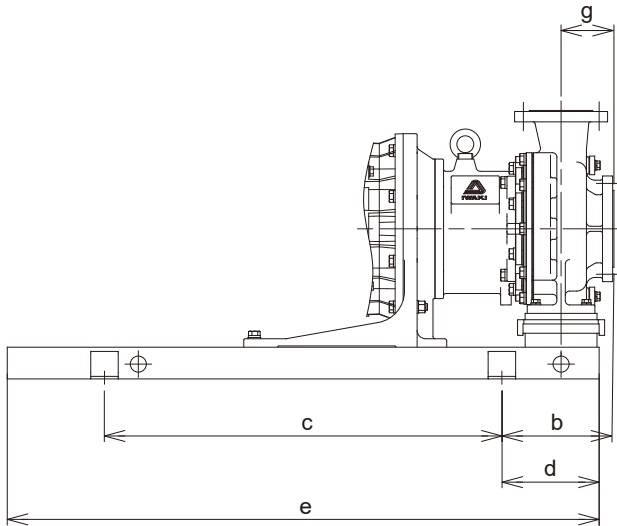

■ Foot mounted flange motor

See the approval drawing for detail dimension.

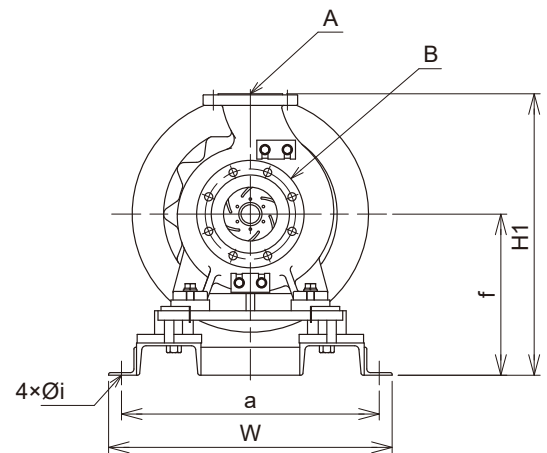
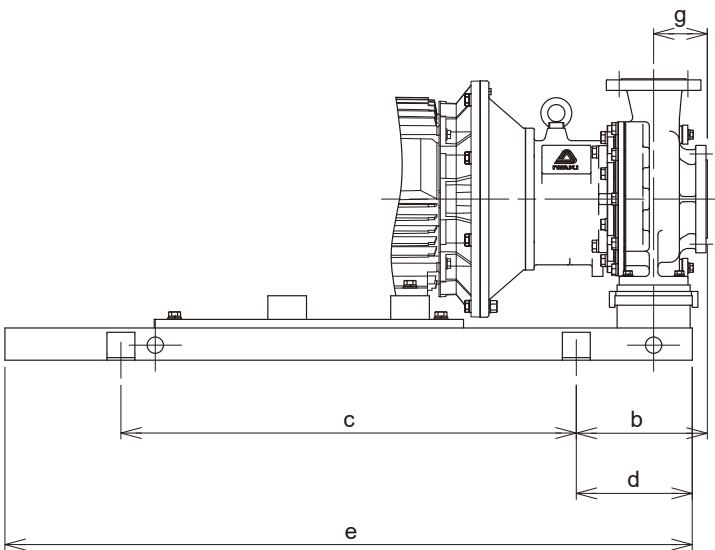

Outline

MDW50

Unit: mm

Motor output (kW)	W	H1	a	b	c	d	e	f	g	i	A	B	Weight (kg)*								
2P	22	560	580	490	255	840	205	1250	125	23	50	80	290								
	30	610		550	280	940	230	1400		355			27	295							
	37			600	600	320	1060	270		1600				375	290						
	45	730	670	350	1200	300	1800	305													
	4P	11	560	580	490	255	840	205		1250			355	23	50	80	290				
		15																610	550	280	940
18.5		600							600		320	1060							270	1600	375
22		730	670		350	1200	300	1800	305												
30		610	600		490	255	840	205	1250	355	23	50		80			290				
37																		670	350	1200	300

MDW80

Unit: mm

Motor output (kW)	W	H1	a	b	c	d	e	f	g	i	A	B	Weight (kg)*								
2P	37	610	635	550	265	940	230	1400	355	27	80	125	280								
	45												655	600	305	1060	270	1600	375	295	
	55	660		670	335	1200	300	1800					310								
	75	730		295																	
4P	11	560	635	490	240	840	205	1250	355	23	80	125	295								
	15													610	550	265	940	230	1400	27	300
	18.5														600	600	320	1060	270	1600	375
	22	730		670	335	1200	300	1800		310											
	30	610		600	490	240	840	205		1250			355	23	80	125	295				
	37																	670	335	1200	300

MDW100

Unit: mm

Motor output (kW)	W	H1	a	b	c	d	e	f	g	i	A	B	Weight (kg)*								
2P	37	610	635	550	265	940	230	1400	355	27	100	125	285								
	45												655	600	305	1060	270	1600	375	300	
	55	660		670	335	1200	300	1800					315								
	75	730		300																	
4P	11	560	635	490	240	840	205	1250	355	23	100	125	300								
	15													610	550	265	940	230	1400	27	305
	18.5														600	600	320	1060	270	1600	375
	22	730		670	335	1200	300	1800		315											
	30	610		600	490	240	840	205		1250			355	23	100	125	300				
	37																	670	335	1200	300

*Pump weight without motor

Outline

6. Precautions for use

Read through this section before operation.

CAUTION

- **Do not run pump dry**

Sliding parts always need liquid in the pump chamber for lubrication and cooling. Do not produce dry running or closed-discharge operation. The pump unit will be damaged.

*If the pump runs dry by mistake, turn off power and leave it for more than one hour to cool it down. Do not refill the pump chamber soon. Quick cooling can give rise to cracks on parts.



- **Be sure to prime the pump before operation**

Always prime the pump when the pump is empty or when the pump is used for the first time or after disassembly/assembly. If the pump is run without priming water, internal parts are excessively worn by friction heat and fatal pump damage results.



- **Do not use the pump in any condition other than its intended purpose**

The use of the pump in any conditions other than those clearly specified may result in failure or injury. Use this product in specified conditions only.



Prohibited

- **Qualified personnel only**

The pump should be handled or operated by qualified personnel with a full understanding of the pump. Any person not familiar with the product should not take part in the operation or management of the pump.



1. Use this pump for sending a liquid only

This pump is not capable of closed-discharge operation. Always keep the minimum flow.

Minimum flow

Model	Motor poles	2P	4P
MDW50		12 m ³ /hr (200 L/min)	12 m ³ /hr (200 L/min)
MDW80/100		60 m ³ /hr (1000 L/min)	12 m ³ /hr (200 L/min)

2. Observe the following conditions. Contact us or your nearest distributor for detail.

- The pump is not capable of slurry and should not be used for it.
- Maximum liquid viscosity: 120 mPa•s Contact us before sending a liquid over 120 mPa•s.
- Liquid temperature range:

MDW50: -10 - 120 °C	}	Observe the freezing and boiling points of the chemical liquid.
MDW80/100: -10 - 105 °C		

Allowable liquid temperature range varies with chemical liquid. Contact us when a liquid temperature is at or below 0 °C.
- Ambient temperature: 0-40 °C
- Ambient humidity: 35-85 %RH

*Before operation, see the specification sheet for pump performance.

Outline

3. Maximum operating pressure (Discharge pressure limit)

See the graph below for the maximum operating pressure. Always keep a pressure in the pump head within the limit, taking account of specific gravity and suction pressure.

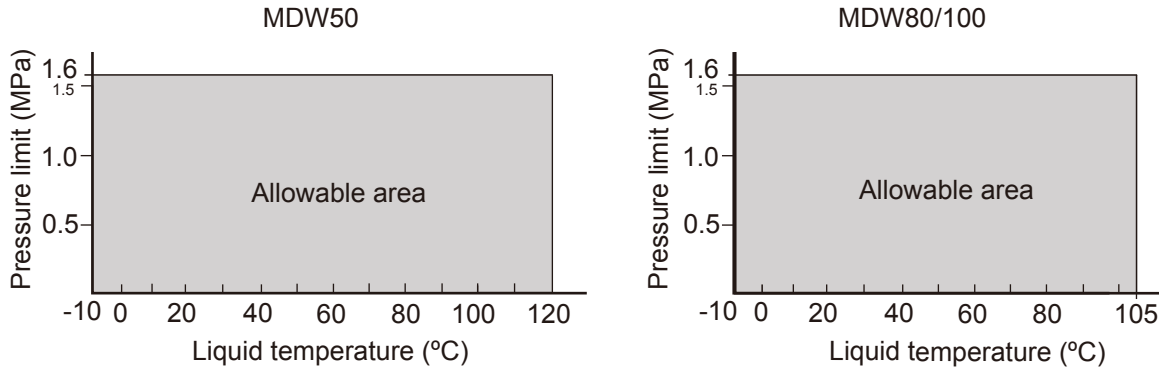

4. Liquid temperature at each model

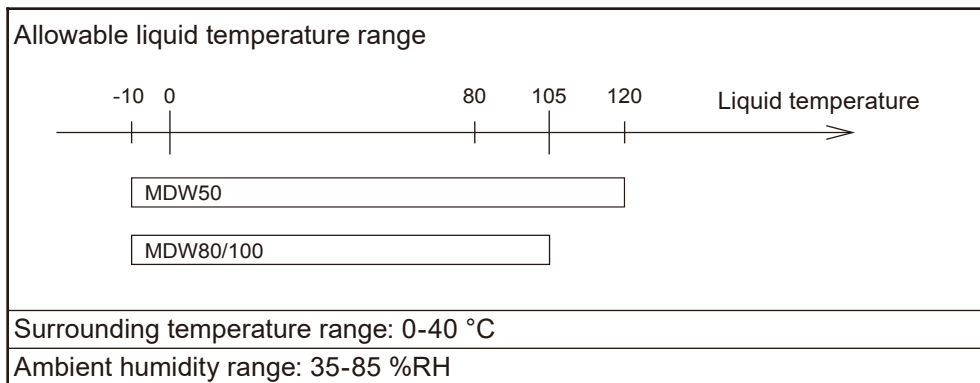

*Note that viscosity, vapour pressure or corrosiveness changes with liquid temperature. The change is shown in performance such as flow rate while the pump itself is not affected.

- a. The pump may not send bubbly liquid or high vapour temperature liquid. The allowable liquid temperature range changes with chemical liquid.
- b. Contact us when liquid temperature is at or below 0 °C or beyond the allowable liquid temperature range. The relation between temperature and viscosity, corrosion resistance, freezing, and condensing need to be taken into consideration.
- c. The allowable liquid temperature range changes with each chemical. See the corrosion resistant table in a separate volume of the Technical information for the allowable liquid temperature range at each chemical.

5. When sending high or low temperature liquid

For high temperature liquid transfer, observe the operating temperature limit of the motor. For low temperature liquid transfer, condensation may build up on the drive magnet and rear casing. In this case, conduct dehumidification.

Outline

6. Slurry

This pump is not designed for sending slurry but then is able to send slurry depending on concentration, particle size and hardness. Contact us for detail.

7. Performance change with specific gravity and viscosity

Shaft power, a flow rate and a delivery head vary with the specific gravity and viscosity of liquid. The pump is designed according to a specified condition. Contact us before changing the specified condition.

8. Use of pump under a negative pressure

Do not use the pump under a negative pressure. Otherwise, the rear casing may deform. If a decompression tank or sealed tank is used in your system, always keep the discharge pressure in the pump head to atmospheric pressure or more at any time during operation or stop. Contact us for detail.

9. Storage

Observe the following requirements for the storage.

1. Cover the inlet and outlet for keeping away foreign matter.
2. The pump should be stored indoors, free from exposure to water and high humidity.
3. Drain liquid out of the pump unit completely for storage after operation. Clean and inspect the pump unit as necessary.

*See manufacturer's instruction manual for the motor unit and coupling.

10. ON-OFF operation

Turning on/off power frequently, the pump is damaged. Keep the number of ON-OFF operations at or below six times per hour.

11. Centring (Coupling type)

Conduct centring after mounting/dismounting the pump or motor unit. See page 34 for centring. See manufacturer's instruction manual to conduct centring by yourself.

Installation

1. <i>Before installation</i>	18
2. <i>Pipework</i>	19
3. <i>Wiring</i>	22

Installation

1. Before installation

Read through instructions in this section to ensure the optimum performance, safety and service of your pump.

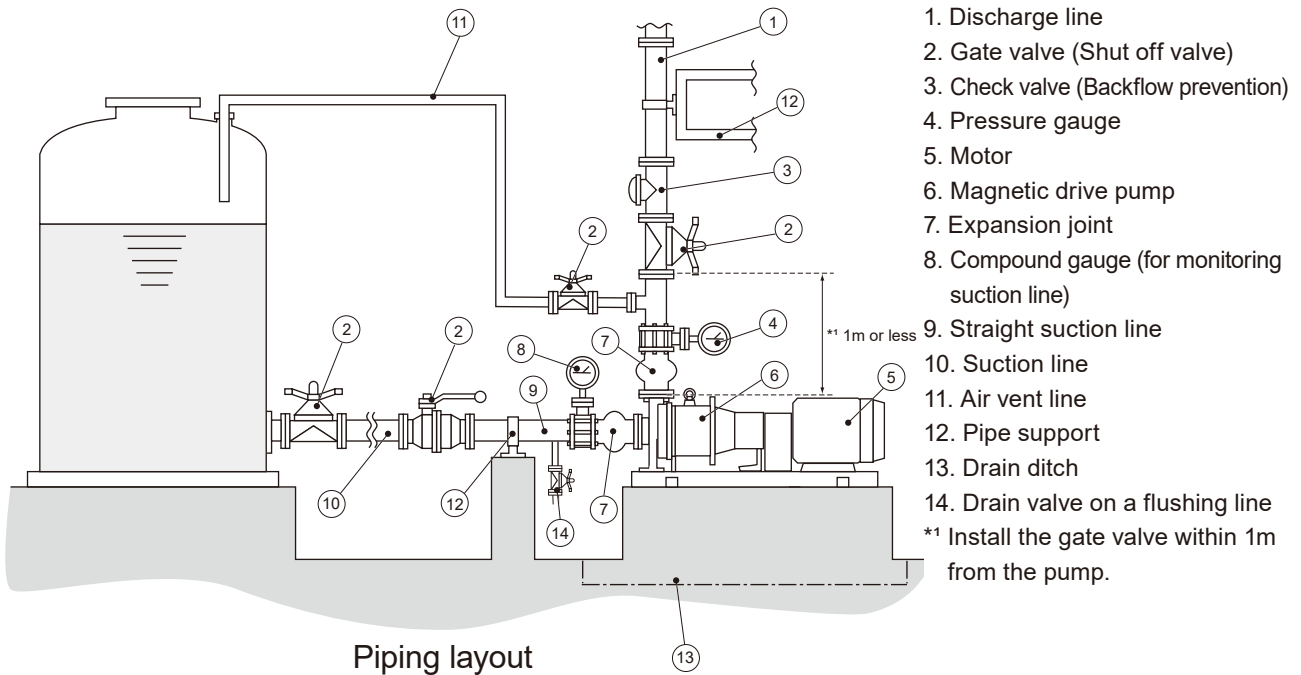

1. Discharge line
 2. Gate valve (Shut off valve)
 3. Check valve (Backflow prevention)
 4. Pressure gauge
 5. Motor
 6. Magnetic drive pump
 7. Expansion joint
 8. Compound gauge (for monitoring suction line)
 9. Straight suction line
 10. Suction line
 11. Air vent line
 12. Pipe support
 13. Drain ditch
 14. Drain valve on a flushing line
- *1 Install the gate valve within 1m from the pump.

■ Installation location

1. Allow sufficient space around the pump for easy access and maintenance.
2. Select a level location, free from vibration, that won't hold liquid. Anchor the pump so it doesn't vibrate. If the pump is not installed level, output may be affected.
3. Use an optimal transportation device when the pump is moved.
4. Ensure protection and containment of solution in the event of plumbing or pump damage (secondary containment).

■ Pump position

1. Install the pump as close to the supply tank.
2. Install the pump under flooded suction.

*Pipe resistance changes with liquid characteristics, specific gravity and liquid temperature as well as piping conditions such as suction line length, affecting the pump performance.

*See "2. Pipework" for detailed information.

Installation

■ Foundation work

1. Use a level to check if a foundation is flat. Securely fix the base by foundation bolts.
2. Insert a shim if there is a gap between the base bottom and foundation surface.
3. The foundation should be larger than a pump base footprint.
4. See the diagram and instructions below as necessary.
5. If the pump unit is not anchored to the foundation and if the motor unit is heavier than the pump unit, the entire pump leans towards to the motor. See page 11 or 13 as well.

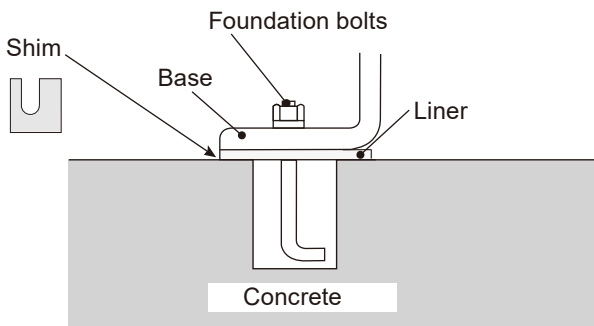

<Foundation work>

- a. Place the pump onto a foundation. Insert liners between the base bottom and foundation surface to keep a mortar injection space.
- b. Screw nuts in foundation bolts until three threads appear after the nuts. And then insert the bolts in threaded holes.
- c. Place a level on the pump base to see flatness. Inject cement mortar into the threaded holes and wait for three days until it has hardened.
- d. Remove the liners after cement mortar has hardened and check flatness again. Then tighten the nuts on the foundation bolts. If there is a gap, insert a shim.

2. Pipework

1. Foreign matter such as sand and scale may enter pipework during pipework. They may cause fatal damage to the pump. Be sure to blow them out before operation. Also, do not apply adhesive too much or leave a screw or nut.
2. If pipework directory weigh on the pump, deformation or damage may result. Be sure to install pipe supports.
3. Clean pipework before installing the pump.
4. Connect the pump to pipework via inlet and outlet flanges according to the table below. (This table is based on use of metal pipe flanges with rubber gaskets.)

Bolt size	Tightening torque (Reference Value)
M16/M20	78.4/100 N·m

5. Tighten bolts diagonally at even torque.

Installation

■ Piping load and momentum

Try not to apply a pipe weight to the pump inlet and outlet flanges. Permissible piping weight and moment to the pump are as below.

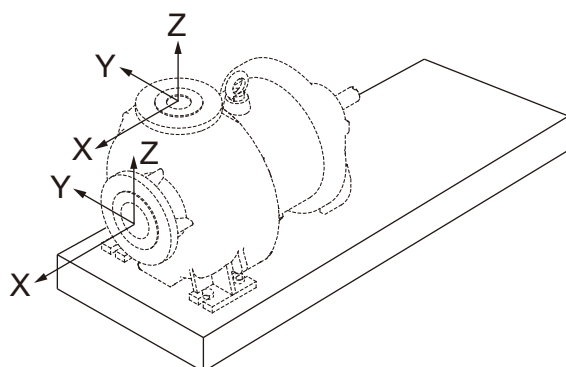

Permissible stress to inlet & outlet flanges

Load direction	Load kN					
	Outlet flange			Inlet flange		
	MDW50 50A	MDW80 80A	MDW100 100A	MDW50 80A	MDW80 125A	MDW100 125A
F _x	1.27	1.93	2.58	1.93	3.04	3.04
F _y	1.16	1.73	2.31	1.73	2.73	2.73
F _z	1.04	1.58	2.08	1.58	2.46	2.46
ΣF	2.00	3.04	4.04	3.04	4.77	4.77

Permissible moment to inlet & outlet flanges

Load direction	Moment kN•m					
	Outlet flange			Inlet flange		
	MDW50 50A	MDW80 80A	MDW100 100A	MDW50 80A	MDW80 125A	MDW100 125A
M _x	1.08	1.23	1.35	1.23	1.62	1.62
M _y	0.77	0.89	0.96	0.89	1.16	1.16
M _z	0.89	1.00	1.12	1.00	1.46	1.46
ΣM	1.58	1.81	2.00	1.81	2.35	2.35

⚠ CAUTION

Install gate valves on both a discharge and a suction line for maintenance. Installing gate valves on the short pipes provided right before the pump inlet & outlet, maintenance will be easier.

Installation

■ Suction line

1. Select an appropriate tank size

Using a high flow pump and small supply tank, a liquid level in the tank changes greatly.

2. End of suction line

Provide a screen in a supply tank for the prevention of foreign matter interfusion (Clean the screen periodically).

3. Install shutoff valves (gate valves)

Install shutoff valves (gate valves) for maintenance and inspection work.

4. Make sure joints on suction line are secure and air doesn't come in

Try to reduce the number of joints. If air enters suction line, liquid may not be pumped or the pump may break at its worst.

5. Do not make an arched line in order to prevent air from being trapped

A suction line right before the pump inlet should be laid on a rising gradient of 1/100 toward the pump.

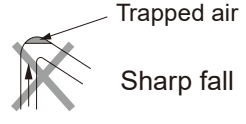
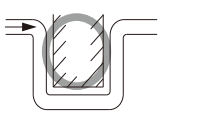
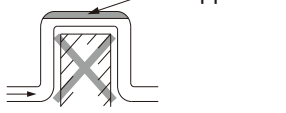
Acceptable	Unacceptable
 <p>Gradual rise</p>	 <p>Trapped air Sharp fall</p>
 <p>Inverted arch piping</p>	 <p>Trapped air Arched piping</p>

■ Discharge line

1. Discharge pipe bore is related to pipe resistance

Pipe resistance rises too high to obtain an intended flow if a discharge pipe bore is too narrow. Degassing efficiency will be affected as well. Install a 500 mm straight pipe right after the pump outlet.

2. Install shutoff valves (gate valves)

Install shutoff valves (gate valves) for flow rate adjustment, operation start/stop, operation maintenance and inspection work.

3. Check valve installation

Install a check valve in the following cases. When selecting a check valve, check its maximum operating pressure to make sure it tolerates a possible pressure rise due to water hammer*1 or backflow.

- a. Discharge line is too long.
- b. Actual delivery head (static discharge head plus discharge pipe resistance) is more than 15 m.
- c. The end of discharge line is 9 m higher than a liquid level in the tank.
- d. Several pumps are running in parallel.

4. Install an air vent line

Lay on an air vent line that branches from between the pump and a check valve for degassing at start-up or maintenance as long as the check valve is provided on a discharge line.

5. Pressure gauge installation

A pressure gauge is required to monitor an operating state.

Glossary*1 Shutting off a discharge line at once, liquid pressure change causes an impact pressure, accompanying impact noise and vibration. This phenomenon is called water hammer. Water hammer damages the pump & pipework and may cause leakage.

Installation

3. Wiring

Electrical work should be performed by a qualified electrician (Contact us as necessary).

Otherwise, personal injury or property damage may result. It is not the manufacturer's responsibility for any failure or injury resulting from noncompliance with this notice.

1. Use the electromagnetic switch which conforms to the motor specifications such as voltage and capacity.
2. The pump and motor do not have protection equipment. Install an overcurrent protection or earth leakage breaker according to motor specification.
3. Electromagnetic switches and push buttons should be installed away from the pump.
4. If the pump is used out of doors, protect switches from rainwater.
5. Outdoor use motors (Indoor use motors can not be installed out of doors). Outdoor use motors can also be used indoors. Protect the motor and electrical power distribution equipment from possible damage, taking account of act of providence.

■ Electrical motor

Check/adjust the motor before operation.

1. Read through motor manufacturer's instruction manual before operation.
2. Check the rotational direction of the motor after wiring.
3. Be sure to earth the motor.

■ Starting

Use a star-delta starter or an inverter to start the pump.

- When taking full voltage starting, wiring work will be done easier, however, electrical facilities suffer a high striking current (five to seven times larger than a rated current) and then the pump suffers high starting torque & an impact load.
- When taking star-delta starting, acceleration torque increases significantly as connection changes from star to delta. Adjust switching time to reduce a shock of the torque increment. Use of an inverter helps smooth starting with a low striking current.

■ Use of an inverter

Use of an inverter can reduce the motor frequency (revolution) and can contribute to energy saving and long life. Observe the following points for controlling the motor with an inverter.

1. Set a basic frequency according to local electrical environment.
2. Observe the maximum frequency.
3. Observe the minimum frequency (about 25 Hz) for individual motor to run continuously. Otherwise, a cooling effect reduces and motor temperature increases, resulting in motor failure or damage.

NOTE: Consult the inverter or motor manufacturer about detail information on the combination of an inverter and motor or how to use.

■ Protection

It is recommended to install the following monitoring devices to protect the pump.

1. Current sensor/Power sensor The sensors monitor the motor load and stop the pump on the detection of load change.
2. Pressure sensor The sensor monitors the starting pressure and stops the pump on the detection of pressure change.
3. Flow sensor The sensor monitors the discharge flow and stops the pump on the detection of flow change.
4. Level sensor The sensor monitors the liquid level and stops the pump when it falls below the specified level.

It is recommended to install two or more monitoring devices. The more monitoring devices are installed, the more possibility of protecting the pump.

The DRN series pump protector (an electric current sensing type abnormal operation preventive device) is also available as an option. Contact us for detail.

Operation

<i>1. Before operation</i>	<i>25</i>
<i>2. Operation</i>	<i>26</i>
<i>3. Shutdown</i>	<i>27</i>

Operation

1. Before operation

CAUTION

- Never run the pump dry or shut off a gate valve on a suction line during operation. This may damage internal parts.
- Stop the pump immediately when it is running under cavitation*1.
- Stop the pump immediately when the magnet coupling is decoupled. Magnetic force reduces if the pump keeps on running for more than one minute in this condition. Remove root cause before resuming operation.
- Keep liquid temperature change within 80 °C at any time during operation or stop.
- (In a flooded suction system,) Start the pump in closed-discharge operation (close a discharge gate valve), and then gradually open a discharge gate valve to adjust a flow in order to avoid water hammer.
- Do not keep the closed-discharge operation for one minute or longer. Otherwise, internal parts may be seized or damaged.
- If power is interrupted while the pump is running, switch off the pump immediately and close a discharge valve. Otherwise, water hammer may occur and damage the pump.
- Take extra care for a discharge pressure not to exceed the pressure limit. Refer to page 15 for the maximum operating pressure.
- Risk of burning. Pump and pipe surface temperature rise high along with liquid temperature. Do not touch the pump or pipe surface directly in or right after operation.



Prohibited



Caution



Caution



Liquid temperature	Possible highest surface temperature (at ambient 40 °C)
105 °C	85 °C
120 °C	100 °C

- The noise level

Noise level	95 dB
-------------	-------

In case the pump noise affects human health or communication to secure a safety, provide a noise reduction cover. Be careful not to reduce the cooling effect by a motor fan.



Glossary*1 Air bubbles caused by a negative pressure in the pump unit, accompanied with vibration and noise. Performance deterioration or part corrosion results.

Operation

2. Operation

1. Fully close a discharge valve and fully open a suction valve.

2. Prime the pump.

- In the flooded suction application, fully open both discharge and suction valves.
- In the suction lift application, prime a suction line as well as the pump.

3. Rotate the coupling by hand (coupling type)

Check power is disconnected and then remove the coupling cover. Turn the coupling by hand to freewheeling in order for the sliding parts in the pump chamber to be lubricated well.

Repeat hand-turning about ten times and mount the coupling cover.

4. Check rotating direction of the motor.

- Close a discharge valve. Power the motor for a quick moment (within 0.5 second) in order to check the rotation direction. A correct direction is shown with an "arrow" mark on the pump (Clockwise seen from motor fan side).
- Check if the motor fan smoothly stops when it is powered off.

NOTE: If the motor does not stop smoothly, check rotating parts.

5. Air elimination

- Before operation, eliminate air in the pump.
- Fully open a valve on an air bleed line or discharge line. Run the pump for 0.5 second and repeat it 5 to 10 times for air elimination. Check a motor fan to see if the motor stops rotating without interruption.

NOTE: Check the rotating parts in the pump head if the rotation is interrupted.

- After air elimination, fully close a discharge valve.

NOTE: In case air bleed line is not equipped, repeat the momentary run several times with a discharge valve open.

CAUTION

Remove gas from the pump before operation. Gas in the pump causes poor liquid flow, or even friction heat may damage internal parts. The gas that stays in between the pump and the nearest valve in a pipe line can decouple the drive magnet and driven magnet as the pump starts running.

6. Starting operation

- Start the pump with a discharge valve fully closed. Stop the closed-discharge operation within one minute.
- Confirm that discharge pressure rises to the shut off pressure.
- Gradually open discharge valve to obtain the specified pressure (capacity).

NOTE: Pay attention to the over-load caused by an excessively opened valve.

Operation

CAUTION

1. Check for loose bolts before operation. Retighten the split plate mounting bolts, the rear casing support mounting bolts and the air vent-/drain-plate mounting bolts by the specified torque. See page 54 and 55 for detail.
2. When the pump keeps running in negative rotation, the pump breaks.
3. Closed-discharge operation should be within one minutes.
4. Make sure that a flow rate is always equal to or more than the minimum. The operation below the minimum flow can reduce the lubricant and cooling effect on the sliding parts. This could lead to failure.

Minimum flow

Model	Motor poles	2P	4P
MDW50		12 m ³ /hr (200 L/min)	12 m ³ /hr (200 L/min)
MDW80/100		60 m ³ /hr (1000 L/min)	12 m ³ /hr (200 L/min)

Daily inspection

Conduct daily inspection to detect abnormality or determine if the pump should be disassembled or not. The operating condition can be checked by discharge pressure, suction pressure, a flow rate, current and voltage.

3. Shutdown

1. *Slowly close a discharge valve.*

Quick closing by a solenoid valve may cause water hammer and damages the pump. Be sure to slowly close any discharge valve.

2. *Switch off and stop the pump.*

Check that the pump stops smoothly. If the pump stops roughly, inspection is needed.

CAUTION

Liquid in the pump may freeze and consequently damage the pump in winter. Drain liquid before storage. When draining harmful liquid, be sure to flush the inside of the pump and piping afterwards.

In the event of a power failure, turn off power and close a discharge valve.

Maintenance

<i>1. Troubleshooting</i>	<i>29</i>
<i>2. Maintenance & Inspection.....</i>	<i>30</i>
<i>3. Spare & Wear parts</i>	<i>35</i>
<i>4. Assembly & Disassembly.....</i>	<i>37</i>

Maintenance

1. Troubleshooting

Be sure to turn off power to stop the pump and related devices before service is performed. If the following measures do not help remove problems, contact your nearest distributor.







Troubles	Symptom		Cause	Point to be checked & Countermeasures
	When a discharge valve is closed.	When a discharge valve is opened.		
Liquid can not be discharged.		The readings of pressure/vacuum gauges drop to zero.	<ul style="list-style-type: none"> • Priming liquid level is too low. • Dry running 	<ul style="list-style-type: none"> • Stop and prime the pump and resume operation. • Dismantle and inspect the pump.
	The pump can not be primed.		<ul style="list-style-type: none"> • A foot valve doesn't close due to foreign matter clogging. 	<ul style="list-style-type: none"> • Clean the foot valve.
	After starting, pressure drops sharply as a discharge valve is opened.	The readings of pressure/vacuum gauges fluctuate and drop to zero.	<ul style="list-style-type: none"> • Air ingress through a suction line or a connection. 	<ul style="list-style-type: none"> • Check if suction line connections are completely sealed. • Check if liquid level in supply tank is not too low.
			<ul style="list-style-type: none"> • A disconnection of the magnet coupling*¹ 	<ul style="list-style-type: none"> • Check amperage to see if the motor is not overloaded. • Check if foreign matter do not lock the impeller or magnet capsule. • Check if voltage is normal.
A pressure gauge keeps showing a low pressure.		<ul style="list-style-type: none"> • Low pump speed • The pump rotates in reverse. 	<ul style="list-style-type: none"> • Check wiring or motor. • Interchange motor wiring. 	
Discharge capacity is too low.	Pressure & vacuum are normal.	Vacuum is high.	<ul style="list-style-type: none"> • The strainer is clogged with foreign matter. 	<ul style="list-style-type: none"> • Remove foreign matter.
		Vacuum is very high.	<ul style="list-style-type: none"> • Air pocket in suction line 	<ul style="list-style-type: none"> • Check and correct suction line.
			<ul style="list-style-type: none"> • Foreign matter are clogged at impeller inlet. 	<ul style="list-style-type: none"> • Remove foreign matter.
		The readings of pressure gauge & vacuum gauge fluctuate.	<ul style="list-style-type: none"> • Air ingress from a suction line or a connection. 	<ul style="list-style-type: none"> • Check suction line connections and retighten as necessary.
			<ul style="list-style-type: none"> • Discharge line clogs with foreign matter. 	<ul style="list-style-type: none"> • Remove foreign matter or scale from piping.
		Vacuum is high but pressure is normal.	<ul style="list-style-type: none"> • Resistance such as air pocket in suction line. 	<ul style="list-style-type: none"> • Check if there is no arched pipework.
	Vacuum is normal but pressure is high.	<ul style="list-style-type: none"> • Actual delivery head is too high or pipe resistance is too large. 	<ul style="list-style-type: none"> • Check actual delivery head and pipe resistance. 	
Pressure is low and vacuum is very low.	Both pressure and vacuum are low.	<ul style="list-style-type: none"> • The motor rotates in reverse. 	<ul style="list-style-type: none"> • Interchange motor wiring. 	

Glossary*¹ A state that the combination unit of the impeller and magnet capsule does not rotate in sync with the drive magnet.

Maintenance

Troubles	Symptom		Cause	Point to be checked & Countermeasures
	When a discharge valve is closed.	When a discharge valve is opened.		
The motor is overheated.			<ul style="list-style-type: none"> • Voltage has dropped greatly. • Overload • Surrounding temperature is too high. 	<ul style="list-style-type: none"> • Check voltage or frequency. • Check specific gravity and viscosity of liquid. • Keep good ventilation.
The flow rate has dropped suddenly.		Vacuum is high.	<ul style="list-style-type: none"> • A suction line clogs with foreign matter. 	<ul style="list-style-type: none"> • Remove foreign matter.
The pump vibrates.			<ul style="list-style-type: none"> • The base is not anchored firmly. • Anchor bolts are loose. • Cavitation occurs. • Pump bearing is worn or failed. • Magnet capsule or impeller is broken. • Dynamic balance of drive magnet is upset. • Motor bearing is worn. 	<ul style="list-style-type: none"> • Fix the base. • Retighten the bolts. • Remove the cause of cavitation. • Replace as necessary. • Replace as necessary. • Investigate problems and replace as necessary. • Replace bearing or a motor unit.

2. Maintenance & Inspection

 WARNING	
<ul style="list-style-type: none"> ● Access limitation The magnet drive pump has a pair of strong magnets (the magnet capsule unit and drive magnet). The strong magnet field could adversely affect the persons who are assisted by electronic devices such as the pacemaker. ● Turn off power before service Risk of electrical shock. Be sure to turn off power to stop the pump and related devices before service is performed. ● Wear protective clothing Always wear protective clothing such as an eye protection, chemical resistant gloves, a mask and a face shield during disassembly, assembly or maintenance work. The specific solution will dictate the degree of protection. Refer to SDS precautions from the solution supplier. 	 Prohibition  Turning off power  Wear protectors
 CAUTION	
<ul style="list-style-type: none"> ● Do not catch the finger The magnetic force of the pump is powerful. Take care not to catch the finger in the bracket. ● Do not touch the pump or pipe with bare hands Risk of burning. The surface temperature of the pump or pipe rises high along with liquid temperature in or right after operation. 	 Caution  Caution

Maintenance

- ▶ Mark each wire so that the wires can be connected correctly to the motor.
- ▶ Do not disassemble the pump beyond the extent shown on this manual.
- ▶ Make sure to close gate valves on the suction and discharge lines before disassembling/assembling the pump. Clean the inside of the pump as well.
- ▶ Magnetic force of the pump is strong. Be careful not to catch the finger in parts. Do not allow iron pieces or powders to be attracted by the magnets.
- ▶ Do not have the magnetic product such as a magnetic disc or a wrist watch close to the magnet capsule or the drive magnet.

CAUTION

Observe the specified tightening torque at each fixing bolt. See the Bearing housing assembly" & "Pump unit assembly" section. Always tighten the bolts diagonally and evenly.

■ Daily inspection

1. *Check whether the pump runs without abnormal noise or vibration.*
2. *Check a liquid level in a supply tank and a suction pressure.*
3. *Check that discharge pressure and a motor current value are as per specifications on the nameplate during operation.*

*A discharge pressure is in proportion to the specific gravity of liquid. The cock of a pressure gauge or a vacuum gauge should be opened only when measurement is carried out. Close it right after measurement. If the cock remains open during pump operation, its meter mechanism may be adversely affected by the abnormal pressure rise caused by water hammer action.

4. *If a spare pump is stored, run it from time to time to keep it ready for operation at any time when needed. Always check for leakage before pump operation. Do not run the pump when liquid leaks.*
5. *Check discharge pressure, discharge capacity, and motor power supply voltage to see if they do not fluctuate during pump operation. See the troubleshooting section on page 29 as necessary.*
6. *Check every connection on the pump and pipework for a leak in operation.*

Maintenance

■ Periodic inspection

To ensure efficient and smooth operation, perform periodic inspection. Be careful not to damage internal sliding parts and plastic parts when disassembling the pump.

Magnetic force of the pump is strong. Be careful not to catch the finger in parts in disassembly/assembly work. Do not have the magnetic product such as a magnetic disc or a wrist watch close to the magnet capsule unit or the drive magnet.

- Inspect the pump every year, logging inspection records.
- For 24-hour continuous operation, inspect the pump every two months.
- Stop operation to disassemble the pump unit and check the internal parts. Try to replace wear parts before they are badly worn. Extra attention is needed to the wear parts used in the magnet capsule and the split plate assemblies. A poor flow or fatal damage may result if they are badly worn.

Part names	Inspection items	Measures
Drive magnet unit	<ul style="list-style-type: none"> ● Wear tracks ● If the drive magnet is correctly mounted by hex. socket set screws and they are not loose. ● Decentering of the magnet and motor shaft (Max.1/10 mm). 	<ul style="list-style-type: none"> ○ Contact us as necessary. ○ Remount the drive magnet to the motor shaft and retighten the screws. ○ Retighten the hex. socket set screws or check the motor. Contact us as necessary.
Rear casing cover	<ul style="list-style-type: none"> ● Wear tracks 	<ul style="list-style-type: none"> ○ Contact us as necessary.
Rear casing	<ul style="list-style-type: none"> ● Wear tracks on an inner surface. ● Cracks ● Contamination in the rear casing. 	<ul style="list-style-type: none"> ○ Contact us as necessary. ○ Replace as necessary. ○ Clean wet ends.
Magnet capsule assembly <Sleeve>	<ul style="list-style-type: none"> ● Wear tracks on the rear end or side face ● Cracks on the rear end or side face ● Check the wear depth on the sleeve. ● Loose fit of the impeller unit ● Cracks on metal shafts 	<ul style="list-style-type: none"> ○ Contact us as necessary. ○ Contact us as necessary. ○ Replace as necessary. ○ Replace or contact us. ○ Contact us as necessary.
Impeller	<ul style="list-style-type: none"> ● Cracks ● Evidence of cavitation ● Impeller clogging ● Deformation of the impeller unit ● Balance hole clogging 	<ul style="list-style-type: none"> ○ Replace as necessary. ○ Remove the root cause of cavitation. Replace as necessary. ○ Clean wet ends. ○ Replace as necessary. ○ Clean the balance holes.
Front casing	<ul style="list-style-type: none"> ● Contamination on wet ends. ● Cracks ● Improper connection with the split plate ● Drain port clogging ● Swollen gaskets and cracks ● Wear tracks 	<ul style="list-style-type: none"> ○ Clean them. ○ Replace as necessary. ○ Contact us as necessary. ○ Clean wet ends. ○ Replace as necessary. ○ Contact us as necessary.
Split plate assembly <Bearing>	<ul style="list-style-type: none"> ● Contamination on wet ends. ● Check the wear depth and grooves on the bearing. ● Wear depth of the thrust and cracks. ● Wear tracks 	<ul style="list-style-type: none"> ○ Clean wet ends. ○ Replace as necessary. ○ Replace as necessary. ○ Contact us as necessary.

Maintenance

■ Wear limit of the bearing and sleeve

Check the wear depth of the sleeve on the magnet capsule assembly and the bearing on the split plate assembly.

The bearing is a wear part. Note that a bearing life varies with operating conditions such as chemical characteristics and pressure. Replace the parts according to the following wear limit.

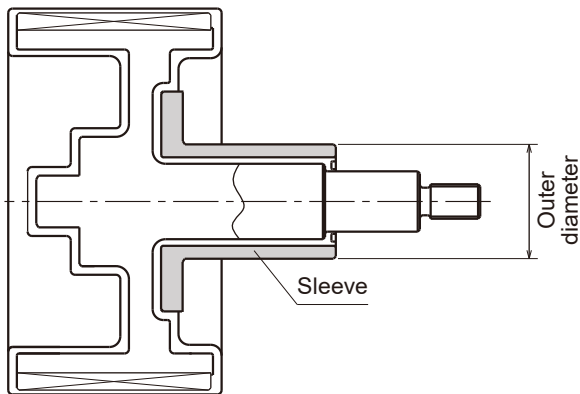

Magnet capsule assembly

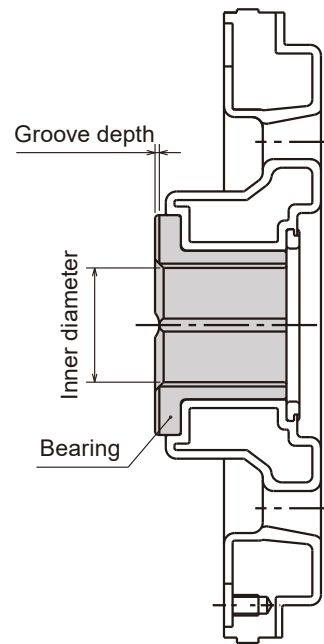

Split plate assembly

Part names		Before use	Wear limit
Magnet capsule assembly	Sleeve outer diameter	ø58 mm	0.25 mm
Split plate assembly	Baring inner diameter	ø58 mm	0.25 mm
	Bearing groove depth	3 mm	1 mm

1. The above table shows wear limits of the bearing and sleeve.
2. If the clearance between the bearing and the sleeve exceeds 0.25 mm, replace them regardless of the wear limit.
3. Sliding parts such as the bearing and sleeve may suffer initial wear in an initial operation phase. Note that this is not abnormal. The initial wear stops hours later.

Maintenance

■ A ball bearing life (coupling type)

The bearing housing on the pump accommodates sealed ball bearings.

Grease filling is not necessary. The life limit and heat resistance of grease change with operating conditions. Conduct periodic inspection.

Check and log the mechanical noise, vibration and surface temperature of the bearing housing every day to detect trouble on the ball bearings at an early stage.

<Time for replacement>

Replace the ball bearings at the end of life. See the wear parts section on page 36 to get a rough idea on the time for replacement.

Periodically check for water ingress, seizing, corrosion and cracks. Replace the ball bearings before the time for replacement as necessary. The ball bearings are a precision component. Handle it with care.

■ Centring (coupling type)

Centre the coupling after the pump unit and the motor unit are separated for maintenance and then integrated again.

Observe an allowable angle error, horizontal error and flange face-to-face dimension error.

For correcting a horizontal error, align each part of the coupling on a straight edge at both top and side lines.

See manufacturer's instruction manual or specification sheet to conduct centring by yourself.

Use a clearance gauge and check a gap. Use a shim as necessary.

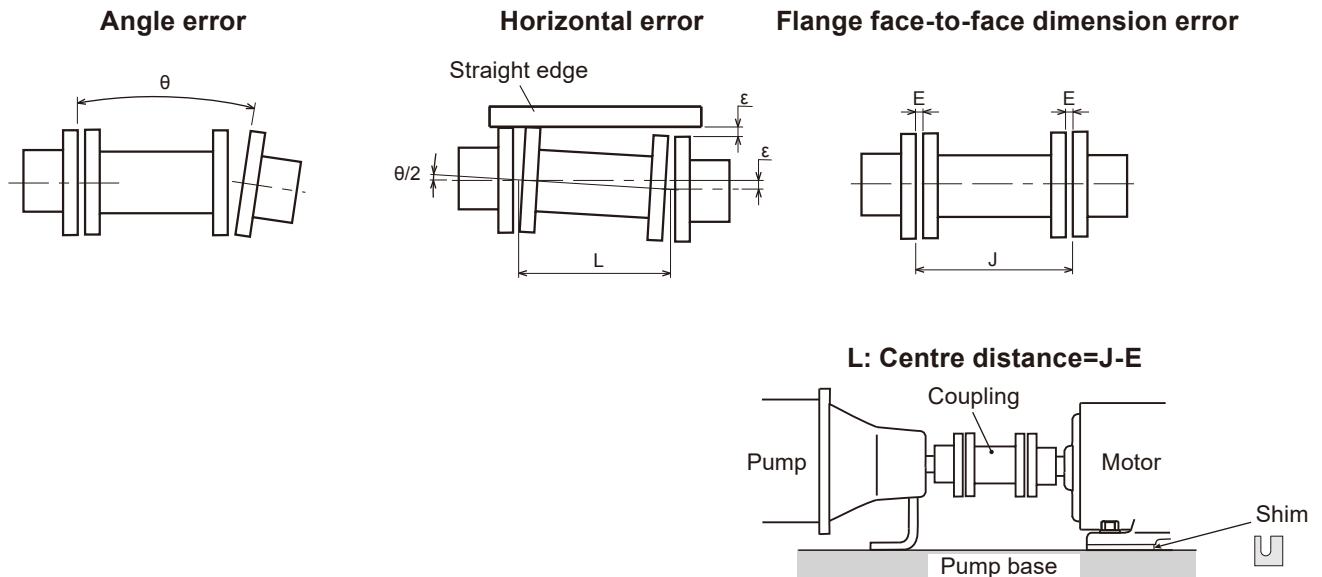

Maintenance

3. Spare & Wear parts

Appropriate spare parts are necessary for a long period of continuous operation. We recommend that wear parts be always in stock. Place an order for spares with the following information.

1. Part names and part number (See an approval drawing if you have.)
2. Pump model identification code and Mfg number (See specification label.)

■ Spare parts

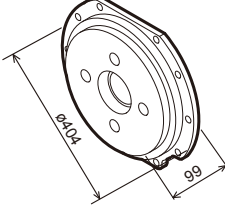
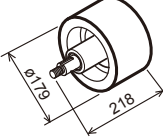
No.	Part names	Contents	Q'ty	Remarks
230	Impeller		1	
337 + 314 + 540	Split plate assembly		1	Split plate + Bearing + Thrust
370 + 859	Magnet capsule assembly		1	Magnet capsule unit + Sleeve

Maintenance

■ Wear parts

Place an order for spares with the pump model, a part name and a part number. The time for replacement shown below is based on an operating condition with ambient temperature clean water and changes with operating conditions such as a liquid characteristic and temperature. Take the time for replacement as a guide. Stock wear parts such as bearing and sleeve for emergent replacement or repair.

Part No.	Part names	Time for replacement	
310	Bearing	10,000 Hr (NOTE1)	
370	Sleeve	10,000 Hr (NOTE1)	
321	Ball bearing	15,000 Hr at 50 °C or below (NOTE2)	
400.1	Gasket	At every periodic inspection (NOTE3)	
400.2	Gasket	At every periodic inspection (NOTE3)	
400.5	Drain gasket	At every periodic inspection (NOTE3)	
400.6	Air vent gasket	At every periodic inspection (NOTE3)	
412.1	O ring	Kalrez®	At every periodic inspection (NOTE3)
		FKM	At every periodic inspection (NOTE3)
		EPDM	At every periodic inspection (NOTE3)
412.2	O ring	Kalrez®	At every periodic inspection (NOTE3)
		FKM	At every periodic inspection (NOTE3)
		EPDM	At every periodic inspection (NOTE3)
420	Oil seal	Replace it along with the ball bearing.	
-	Fluorinated grease	Apply when assembling the pump unit (NOTE4).	

NOTE 1: Replace the bearing and sleeve with new ones when they have been worn badly before the time for replacement. See page 33 for detail.











NOTE 2: The ball bearing life may be reduced under a harsh operating condition. Try to replace wear parts before they are badly worn.

NOTE 3: Replace gaskets and O rings every time the pump unit is disassembled for maintenance. Note that sealing performance is reduced if gaskets and O rings are reused.

NOTE 4: Contact us for the fluorinated grease.

Maintenance

4. Assembly & Disassembly

 WARNING	
<ul style="list-style-type: none"> Access limitation The magnet drive pump has a pair of strong magnets (the magnet capsule unit and drive magnet). The strong magnet field could adversely affect the persons who are assisted by electronic devices such as the pacemaker. Turn off power before service Risk of electrical shock. Be sure to turn off power to stop the pump and related devices before service is performed. Wear protective clothing Always wear protective clothing such as an eye protection, chemical resistant gloves, a mask and a face shield during disassembly, assembly or maintenance work. The specific solution will dictate the degree of protection. Refer to SDS precautions from the solution supplier. Ventilation Fumes or vapours can be hazardous with certain solutions. Also, a harmful fluorine gas is given off when a fluoroplastic part of this product is heated to a high temperature and eventually decomposed. Ensure proper ventilation at the operation site. 	 Prohibition  Turning off power  Wear protectors 
 CAUTION	
<ul style="list-style-type: none"> Do not catch the finger The magnetic force of the pump is powerful. Take care not to catch the finger in the bracket. Do not allow foreign matter such as iron pieces to adhere to the magnet capsule unit. Use the eye bolt or lifting holes Use the eye bolt when lifting the pump unit only or use lifting holes on the base if the pump unit is mounted on it. In the latter case, do not use the eye bolt. Use an overhead crane or any other proper transporting machine. Two or more operators may be needed for ensuring safe transport depending on the pump size and weight. Attention to magnetic force A pair of strong magnets is mounted in the pump and its magnetic force may affect magnetic disks/cards or wrist watches. Do not bring them close to the pump. Do not touch the pump or pipe with bare hands Risk of burning. The surface temperature of the pump or pipe rises high along with liquid temperature in or right after operation. 	 Caution  Caution   Prohibition

Necessary tool list

No.	Names	MDW50/80/100	Remarks
1	Spanner	Nom. dia: 13, 19 and 24mm	For M8, M12 and M16
2	Hexagon wrench	Width across flat: 5, 6, 8 and 14 mm	For M6, M8, M10 and M16
3	Bearing removal/press-fit tool	ø70×100L One each	Plastic bar: The end of bar should be flat. We can make the bar if requested.
4	Oil seal press-fit tool	ø54×50L One each	
5	Plastic welder or dryer	One each	
6	Hand press	One each	
7	Plastic hammer	One each	
8	Puller	One each	150 and 300 mm class
9	Torque wrench	Two each (Large and small ones)	50 and 100 N·m class
10	Bar	Two each	300 mm class
11	Guide bolts (Attachments)	Two each	
12	Hex bolts (Attachments)	Two each	M12×130

Maintenance

■ Flange motor

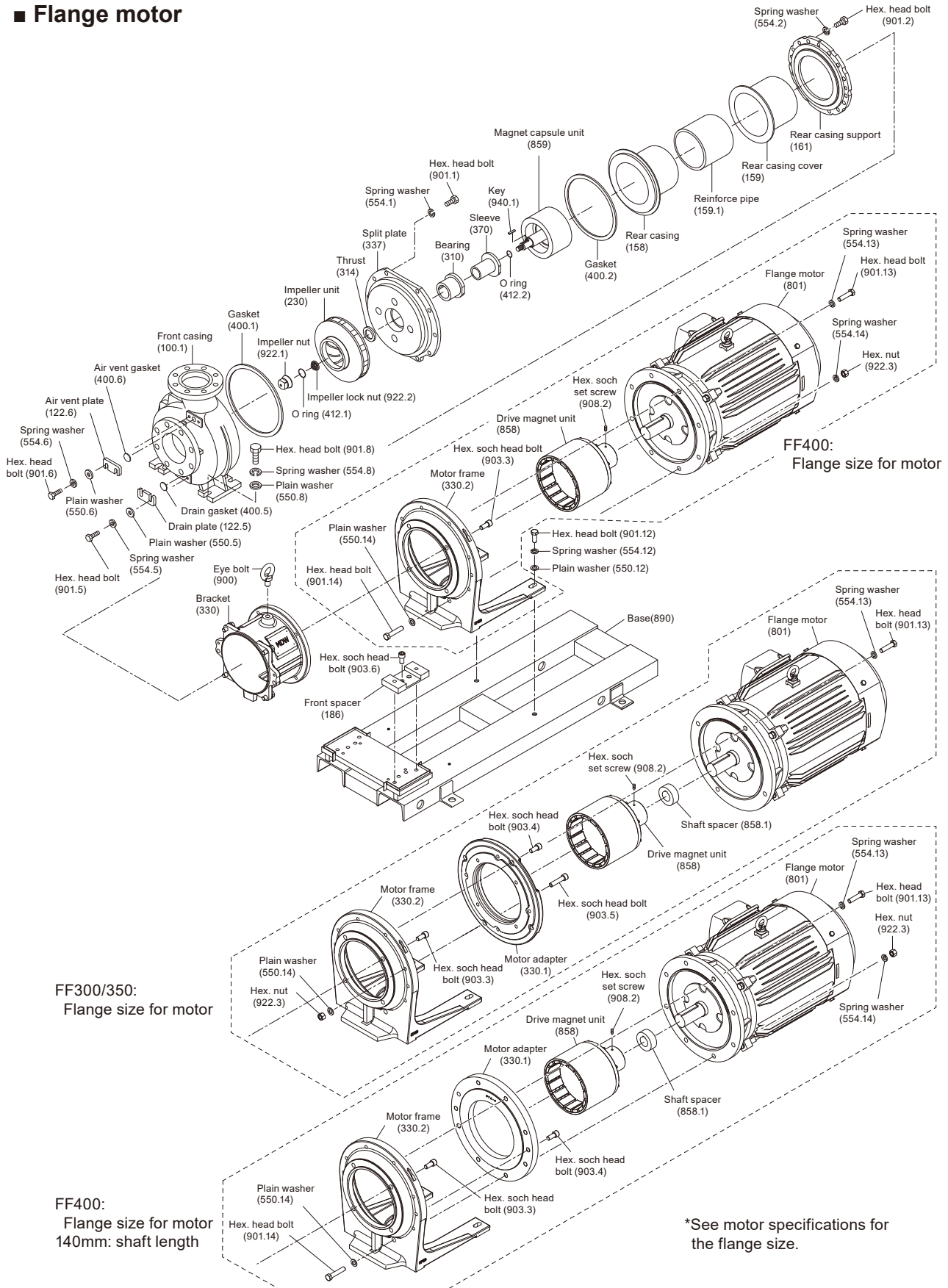

Maintenance

■ Foot mounted flange motor

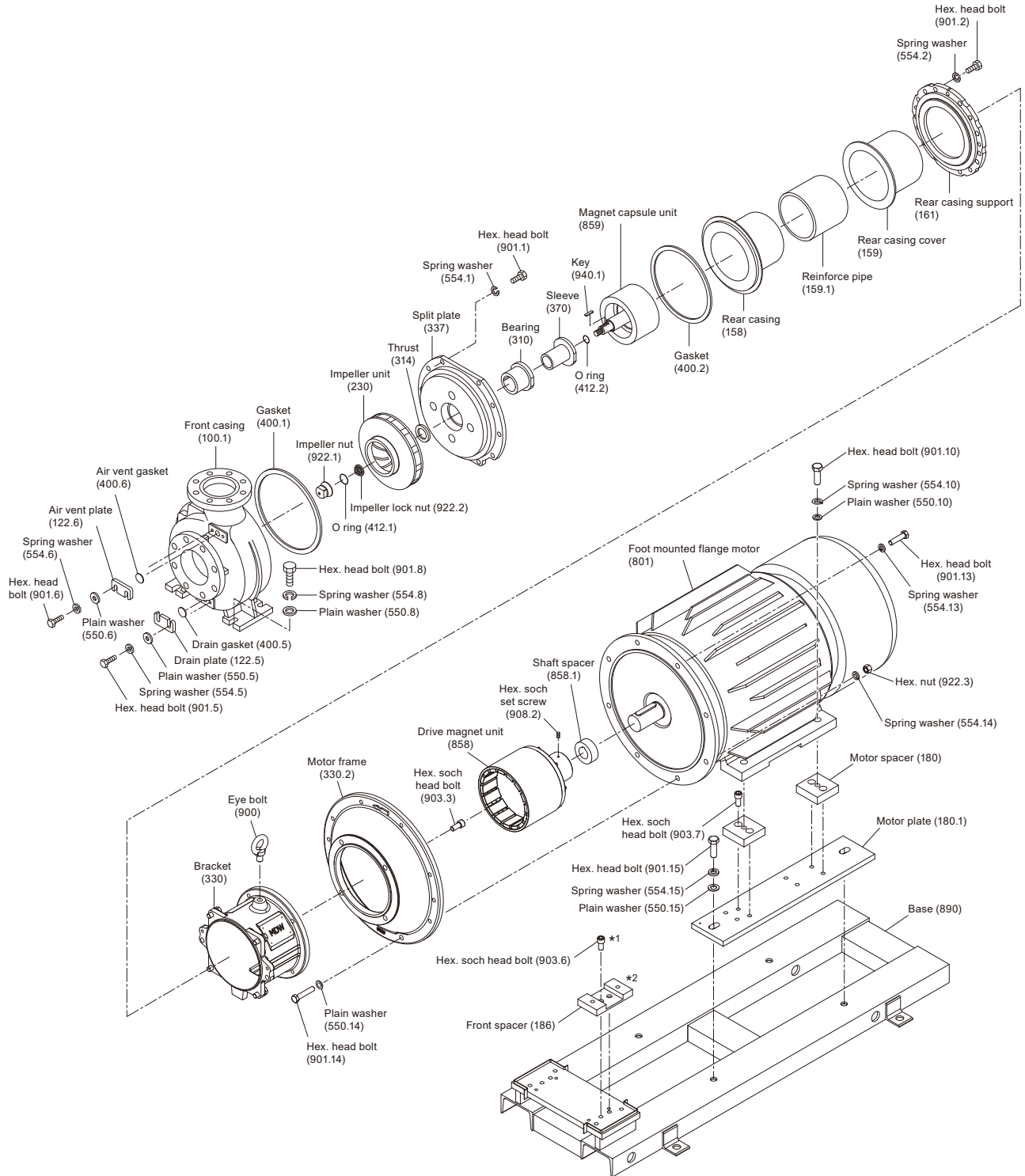

*1 For the MDW100 model

*2 For the MDW50/100 models

Maintenance

■ Pump unit disassembly

1. Remove the hex. head bolts (901.5) on the drain plate to release chemical liquid out of the pump unit.

⚠ CAUTION

Solution in the pump unit and the discharge line may be under pressure. Release the pressure from them before disconnecting plumbing or disassembly of the pump to avoid solution spray.

Loosen the hex. head bolts (901.6) to adjust a drainage rate as necessary.

For the pump models without drain and air vent ports, neutralize or flush chemical liquid out of the pump unit before disassembly work.

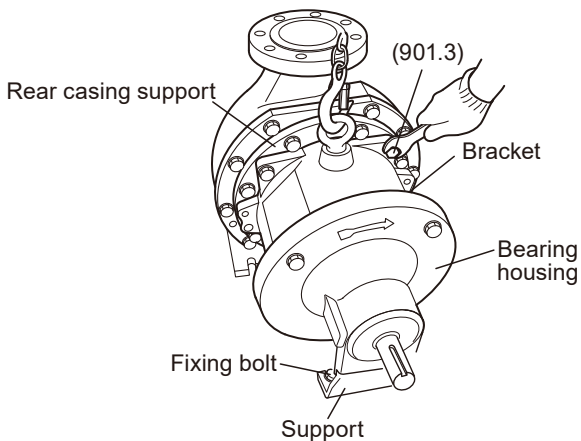
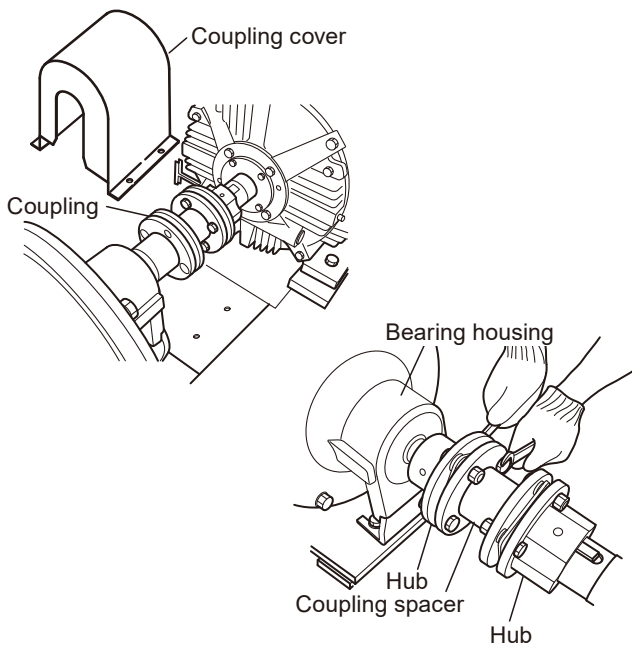
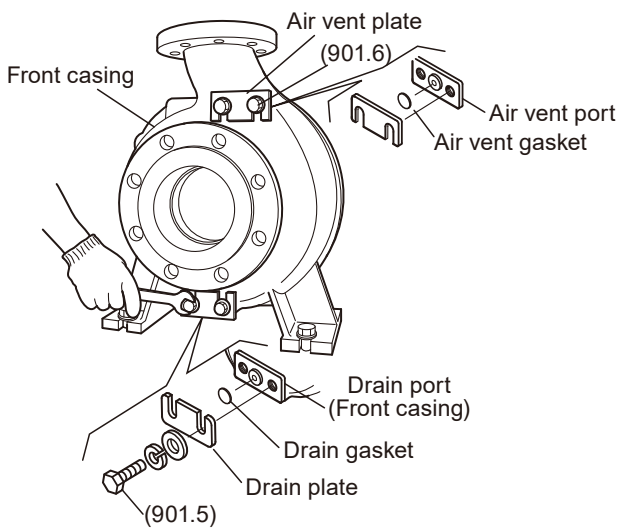

2. Remove the coupling cover and the coupling spacer. Remove hubs as necessary. See manufacturer's instruction manual for handling of the coupling (coupling type).

3. Remove the bolts which are fixing the rear support to the base (coupling type).

*Lift and move the motor unit backward to make a space for the bearing housing removal. Or disconnect the pump unit from pipework and move it forward.

4. Remove the hex. head bolts (901.3) which are fixing the bracket.

5. Remove the mounting bolts (901.12 or 901.15) of the base (890).

Maintenance

- Use an overhead crane or any other proper transporting machine to catch/hold the bracket and the motor horizontally and pull it back.

*Make sure the drive magnet (858) does not hit the rear casing cover (159).

⚠️ WARNING

Use rope to always keep the motor level.

- Screw the guide bolts into the rear casing support via both bottom holes on the bracket edges.

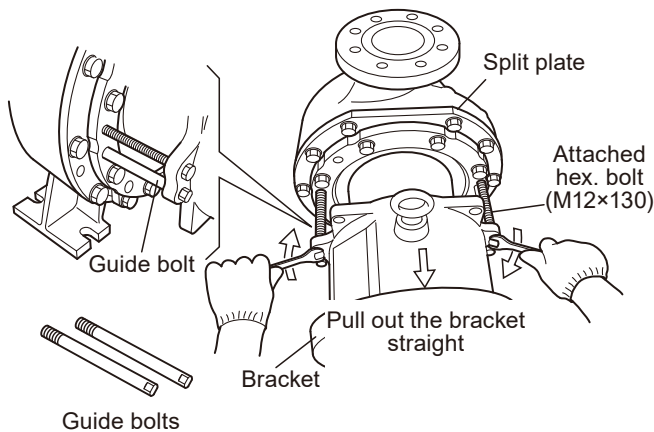

- Take the attached two hexagon bolts (M12x130) and screw them into both upper holes on the bracket edges in order to pull the bracket out of the pump unit. Always screw the bolts in turn diagonally and evenly.

Remarks

Guide bolts help you pull the bracket out straight and also prevents the drive magnet unit from clashing with the rear casing cover.

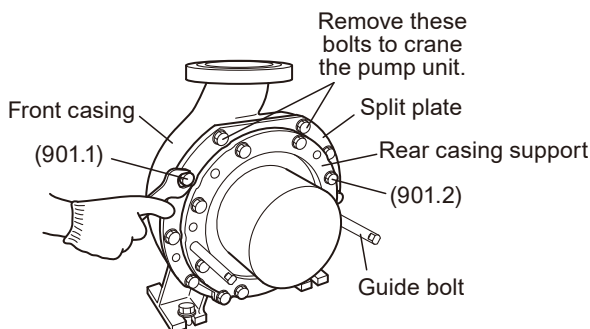

- Unscrew guide bolts from the rear casing support. And then screw the bolts into the front casing through the split plate.

*Remove two split plate fixing bolts (upper ones) and hook the pump unit by the crane in order to support the split plate and accompanying parts. Be careful not to scratch the sealing surfaces on the front casing and the split plate.

⚠️ CAUTION

Be careful not to get wet with residual chemical liquid in the pump unit.

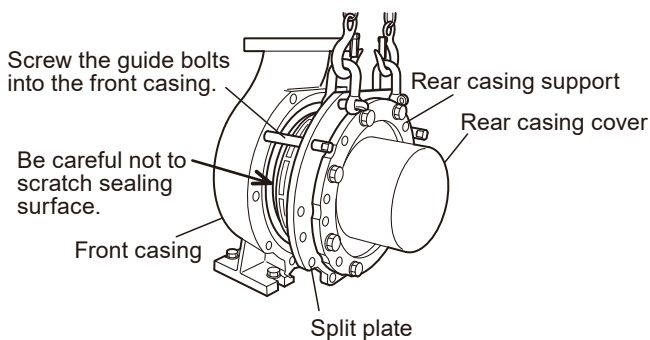

Maintenance

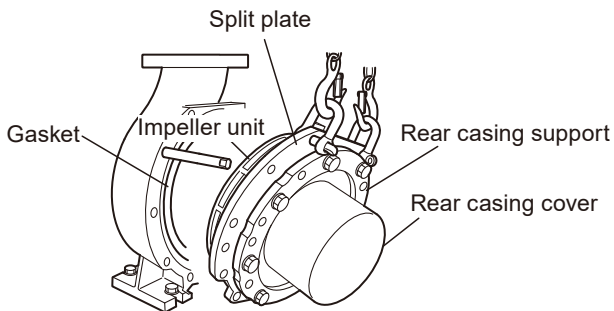

10. Crane the split plate with accompanying parts to separate them from the front casing.

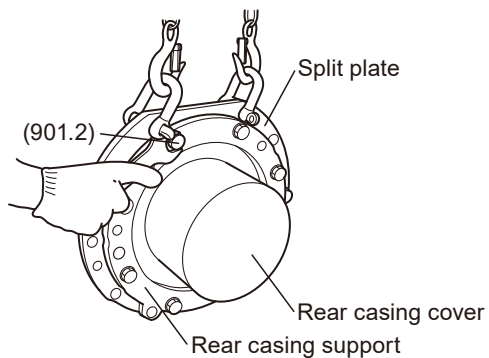

11. Remove the hex. head bolts (901.2) and remove the rear casing support.

CAUTION

Be careful not to get wet with residual chemical liquid in the pump unit.

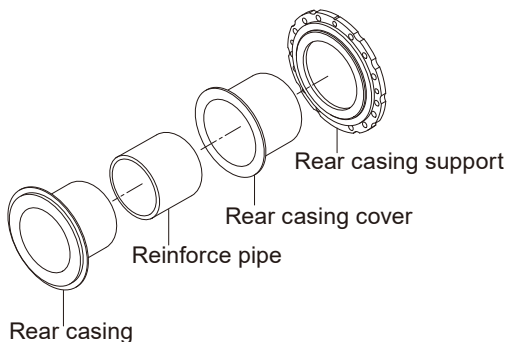

12. Remove the rear casing cover and the rear casing. Be careful not to scratch a sealing surface on the rear casing.

*Do not remove the reinforce pipe from the rear casing.

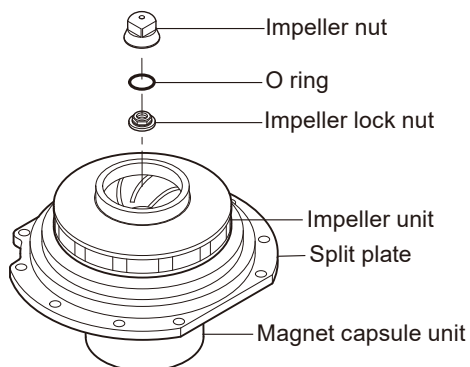

13. Remove the impeller nut and the impeller lock nut.

Maintenance

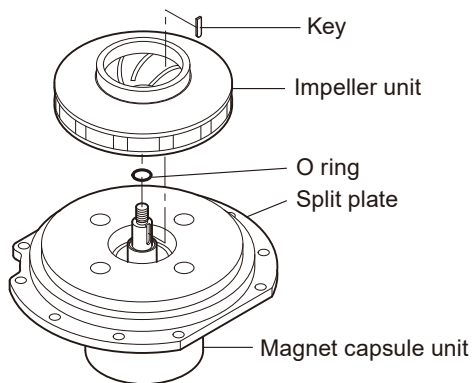

14. Pull the impeller unit out of the split plate. Jiggle the impeller unit as necessary.

*Be careful not to damage the impeller unit when using a puller.

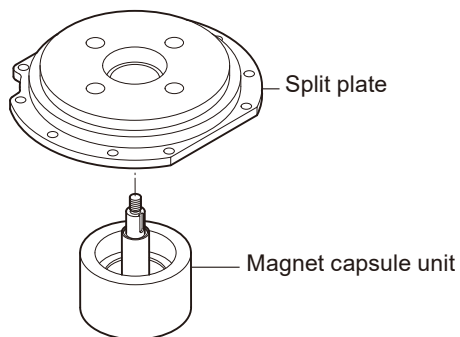

15. Pull the split plate up straight from the magnet capsule unit. Do not tilt the split plate.

Otherwise, the bearing and sleeve may seize.

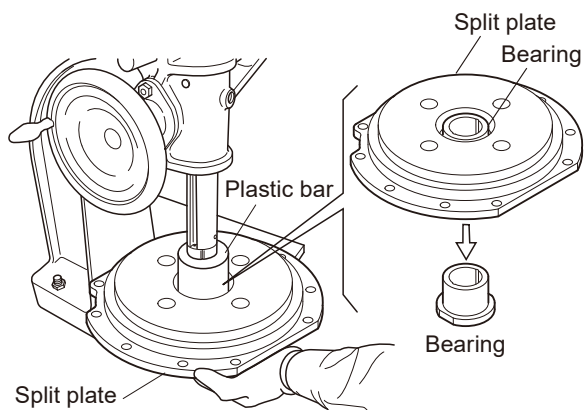

16. When demounting the bearing:

Carefully push the bearing out by the hand press via a plastic bar as necessary.

*Be careful not to drop the bearing onto the floor. Otherwise, the bearing may break.

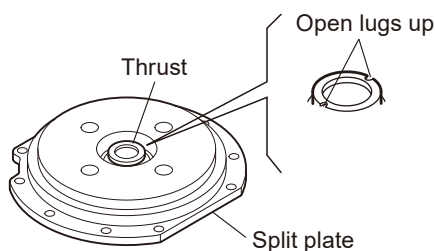

17. When demounting the thrust:

Remove the thrust when it is worn or cracked. Heat the lugs on the thrust by a plastic welder or an industrial dryer and open them up. And then lightly push the thrust out from the other side by a plastic bar or a slotted screwdriver.

Maintenance

■ Drive magnet disassembly (flange type)

• Precautions for disassembly

Make sure the motor is electrically-disconnected in advance. If the motor were to run in this process, personal injury would result.

1. Remove the motor (and bracket) from the pump head.

2. Remove the hex. head bolt (901.13 and 901.14) and the bracket from the motor.

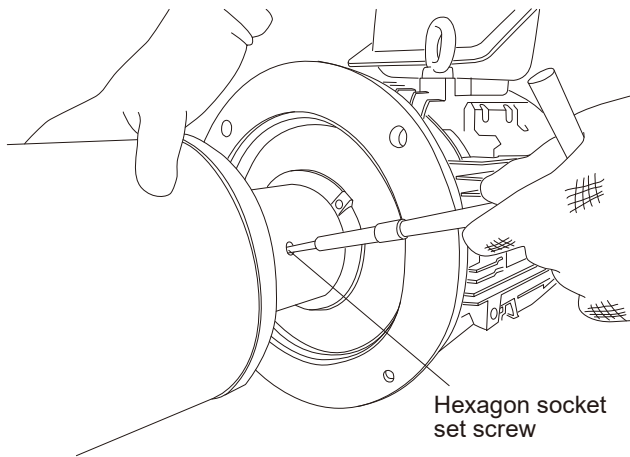

3. Loosen the hex. socket set screws (908.2) and demount the drive magnet (858) from the motor shaft. If necessary, leverage a claw bar as shown below. Do not use excessive force that may damage the motor shaft.

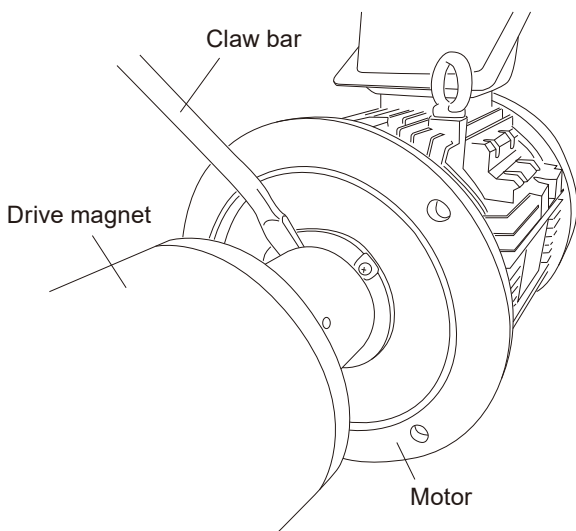

Maintenance

■ Bearing housing disassembly (coupling type)

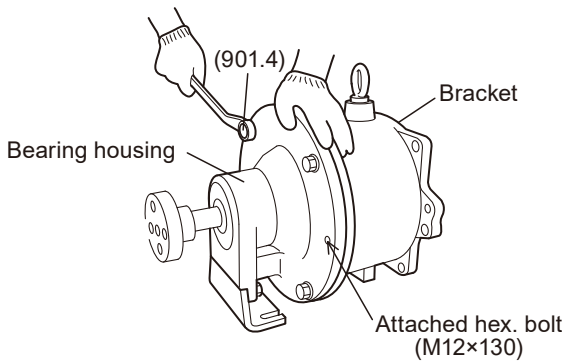

1. Remove the hex. head bolts (901.4) on the bearing housing and detach the bracket. Note that strong magnetic force is attracting the bracket. Be careful not to hit the bracket against the drive magnet unit.

*When it is hard to detach the bracket:
Take the attached two hexagon bolts (M12x130) and screw them into both holes on the bearing housing edges in turn in order to push the bracket out of the bearing housing.

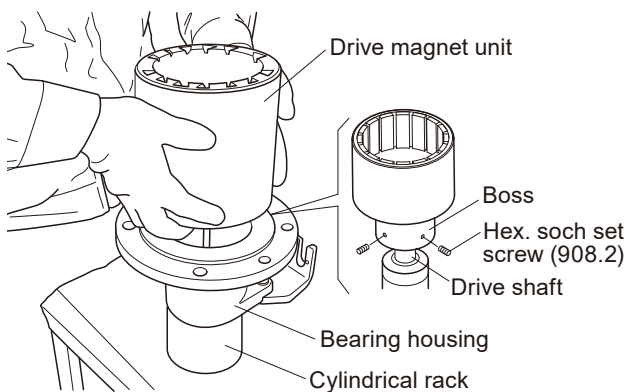

2. Loosen the hex. soch set screws (908.2) and remove the drive magnet unit from the drive shaft. Then remove a key from the shaft.

*When it is hard to detach the drive magnet unit:
Use a lever or puller. Be careful not to damage the inner surface of the drive magnet unit when using a puller. Protect the inner surface with a thick cloth or plastic pipe.
Heating the boss with an industrial dryer will help easy removal.

*The drive magnet unit may drop off when using a lever. Assistance by another person is required.

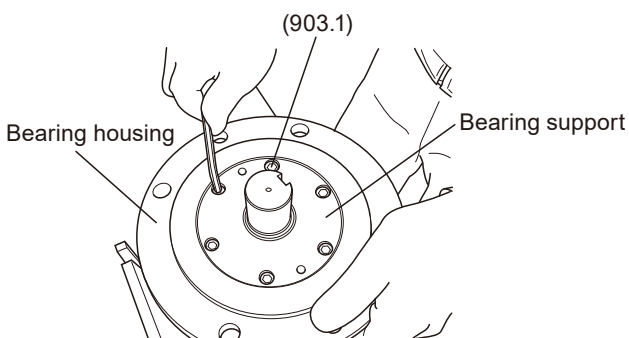

3. Remove the hex. soch head bolts (903.1) and detach the bearing cover.

*The bearing housing slides down as the bolts are loosened as long as the bearing housing is placed with the bearing cover upward, like the left picture shows.

Maintenance

4. Remove the hub and key from the drive shaft.

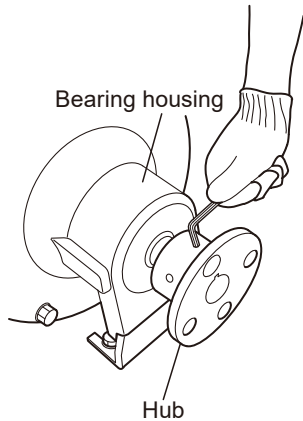

5. Pull out the drive shaft along with the ball bearing from the bearing housing.

*In case the drive shaft can not be removed, tap the shaft end with a plastic hammer to push it out straight.

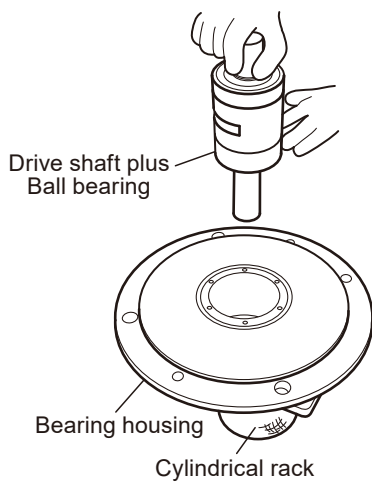

6. Remove the ball bearing and the bearing spacer from the drive shaft.

⚠ CAUTION

Do not scratch the sliding surface on the drive shaft where comes in contact with the oil seal.

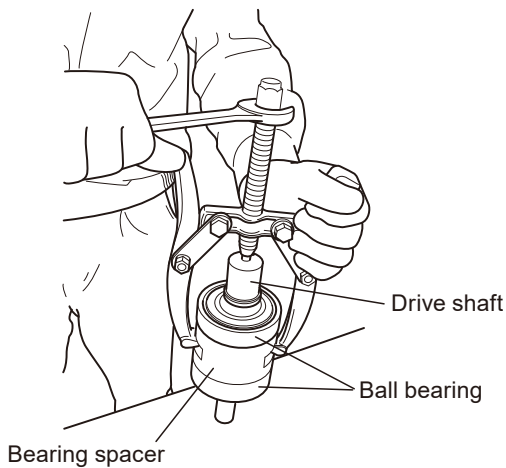

7. Use a slotted screwdriver and take out the oil seal from the bearing housing for replacement as necessary.

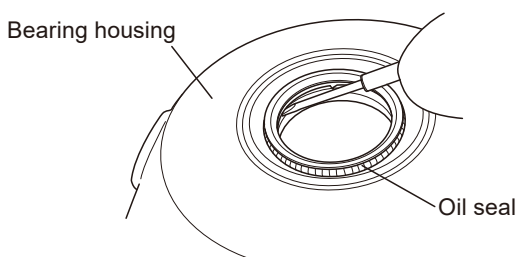

Maintenance

■ Drive magnet assembly (flange type)

• Precautions for assembly

Make sure the motor is electrically-disconnected in advance. If the motor were to run in this process, personal injury would result.

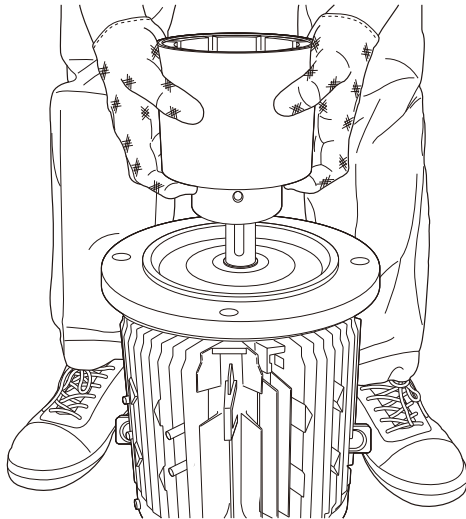

1. Clean the motor shaft surface and the shaft hole of the drive magnet. Use a sand paper or sand blaster to remove burrs if necessary.

*Be careful not to drop the drive magnet, or it may break.

2. Adjust the depth of the hex. soch set screws (908.2) in the drive magnet so they won't hinder the insertion of the drive magnet to the motor shaft.

3. Mount the key to the motor shaft in place beforehand.

4. Slide the drive magnet down to the motor shaft until it bottoms out. Remove burrs or debris or any other obstacles if any. Adjust the key position if necessary.

*If a shaft spacer is provided, slide it to the motor shaft before the drive magnet installation.

5. Tighten the hex. soch set screws (908.2) by the rated torque shown below to fix the drive magnet to the motor shaft. Apply the LOCTITE onto the screw threads.

Tightening torque: 20 N·m

Recommended adhesive: LOCTITE # 243

6. Check the drive magnet is fixed tight and won't loose in operation.

7. Remount the bracket to the motor.

*Always fit the "single" bracket part to the motor first, and then the pump head (driven magnet) to the bracket, on the step by step basis!

Do not fit the combination of the bracket and the pump head (driven magnet) to the motor. There is a very strong magnetic force between the drive magnet and the driven magnet, and there is always the risk of personal injury which could happen when they strongly pull each other.

Maintenance

■ Bearing housing assembly (coupling type)

• Precautions for assembly

Assembly can be made in reverse procedures to disassembly. Pay attention to the following points.

See manufacturer's instruction manual for detail information on the ball bearing and oil seal.

Always apply even torque to each bolts diagonally, in turn.

• Cleaning of the bearing housing

Keep the inside of the bearing housing clean and free from scratches and apply grease for easy ball bearing mounting. Also, clean and apply grease to the oil seal mounting groove and the sliding surface of the drive shaft where comes in contact with the oil seal.

1. Use a hand press to press-fit a ball bearing into the drive shaft.

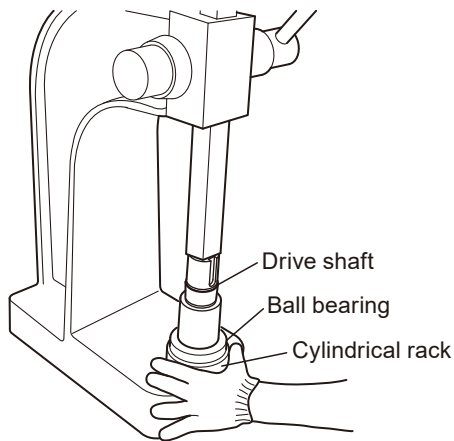

2. Place the bearing spacer on the ball bearing along with its circumference. And then press-fit the other ball bearing into the shaft.

*Be sure to fit the ball bearing into the bearing spacer.

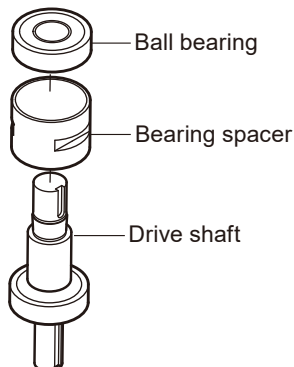

Maintenance

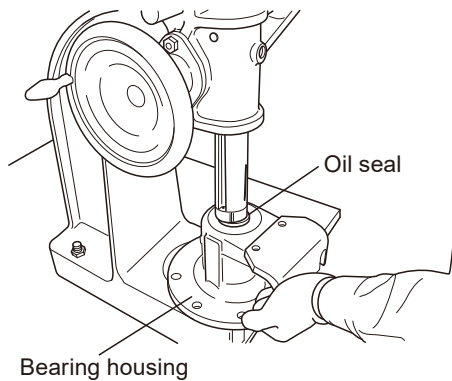

3. Use a hand press to press-fit the oil seal into the groove on the bearing housing via a plastic bar.

*Be sure to apply grease to the groove on the bearing housing and the sliding surface of the drive shaft.

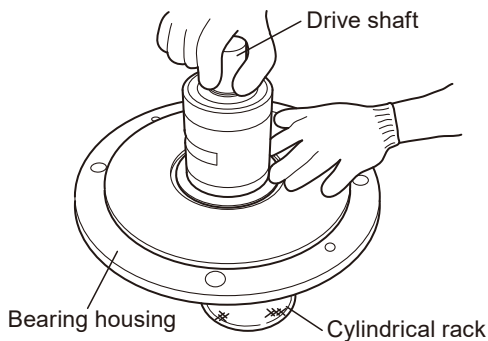

4. Mount the drive shaft assembly into the bearing housing.

*Place the bearing housing on a cylindrical rack. The rack depth should be long enough to accommodate the shaft length.

*Be careful not to slide the bearing spacer out of alignment. Clean the inside of bearing housing and apply grease.

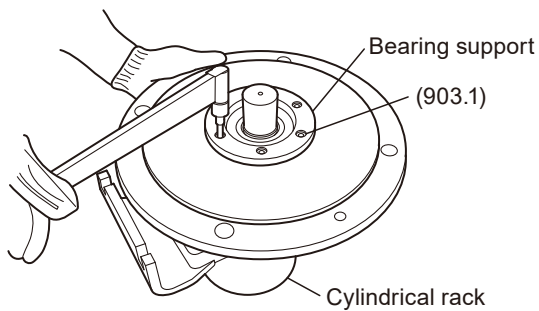

5. Mount the bearing cover with the hex. soch head bolts (903.1).

Tightening torque: 8.0N·m

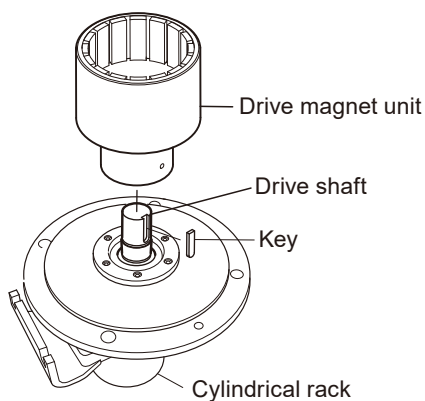

6. Fit the key onto the drive shaft and then mount the drive magnet unit.

Maintenance

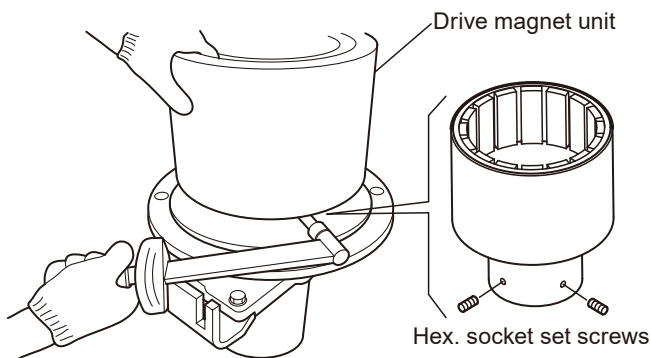

7. Unscrew the hex. socket set screws (908.2) once and apply the LOCTITE to threads. And then screw them to fix the drive magnet unit by the tightening torque below.

Tightening torque: 20 N·m

Recommended adhesive: LOCTITE # 242

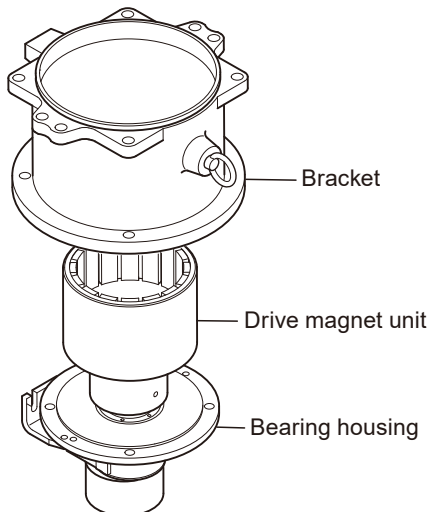

8. Place the bracket to the bearing housing.

*Note that strong magnetic force is attracting the bracket. Be careful not to hit the bracket against the drive magnet unit.

⚠ CAUTION

Be careful not to catch the finger or hand in between the bracket and bearing housing.

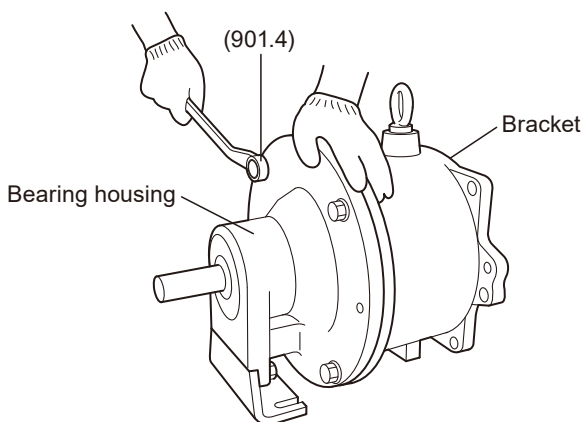

9. Place the bracket and bearing housing on the level and fix them with hex. head bolts (901.4).

Maintenance

■ Pump unit assembly

• Precautions for assembly

Do not clean the pump or nameplate with a solvent such as benzine or thinner. This may discolour the pump or erase printing. Use a dry or damp cloth or a neutral detergent.

• Cleaning of the magnet capsule unit

Do not allow iron pieces or powders to be attracted by the magnets. Get rid of those matters from the magnet capsule unit before assembly.

• Cleaning of ceramic sliding parts: Bearing, Sleeve and Thrust.

Keep the bearing, sleeve and thrust, specially sliding surfaces, clean and free from scratches.

Assembly can be made in reverse procedures to disassembly. Pay attention to the following points.

• Gasket/O ring replacement

Do not reuse a gasket or an O ring which has been removed once. Always replace them with new ones.

Otherwise, sealing performance reduces. Be sure to fit a gasket or an O ring in place. Clean sealing areas before fitting them.

• When fastening bolts:

Always apply even torque to each bolts diagonally, in turn.

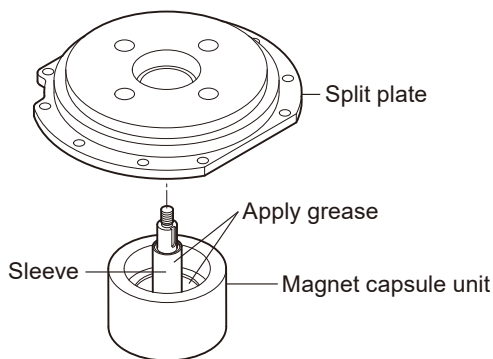

1. Place the O ring into the groove on the shaft of the magnet capsule unit.

2. Put grease at your fingertip and apply it slimly over the sliding surfaces of the sleeve. Wipe off extra grease with a clean cloth. Otherwise, failures such as seizing, speed reduction and over current may result.

3. Mount straight the split plate assembly to the magnet capsule unit. Do not tilt the split plate. Otherwise, the bearing and sleeve may seize.

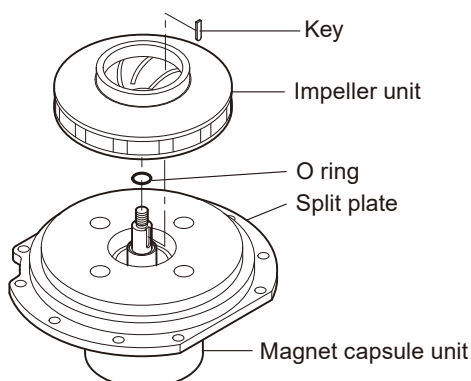

4. Insert the impeller unit to the shaft, mating the key groove.

5. Fit the key into the key groove.

Maintenance

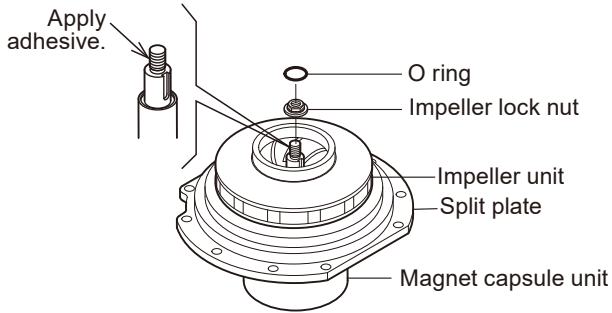

6. Fit the O ring into the groove on the impeller unit in place.

7. Tighten the impeller lock nut while holding the magnet capsule unit. Apply a small amount of adhesive onto the threads of the shaft so as not to allow the nut to loosen.

Tightening torque: 38 N·m

Recommended adhesive: LOCTITE # 222

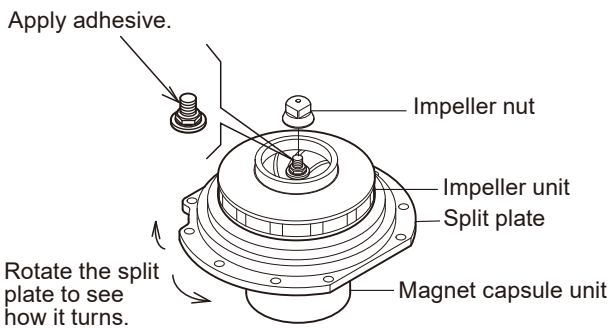

8. Tighten the impeller nut while holding the impeller unit. Apply a small amount of adhesive onto the threads of the shaft so as not to allow the nut to loosen.

Tightening torque: 25 N·m

Recommended adhesive: LOCTITE # 222

*Rotate the split plate right and left to see if it turns smoothly. If the split plate does not rotate, reassemble them.

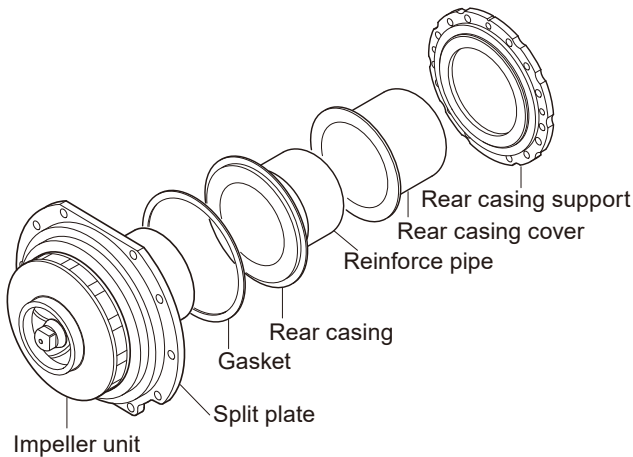

9. Remove foreign matter from the magnet capsule unit. Then place the gasket in the split plate. And then fit the rear casing and the rear casing cover.

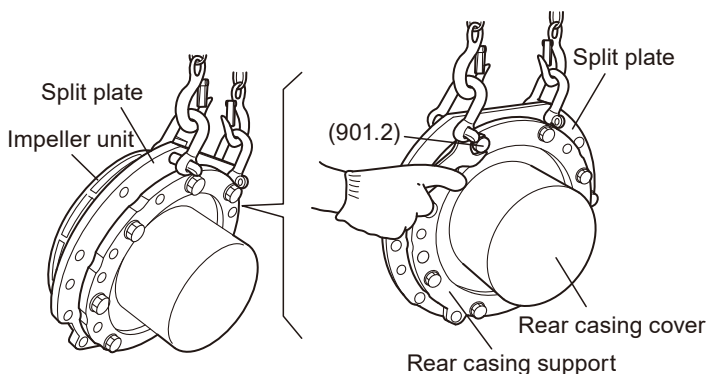

10. Hold up the split plate with the crane for the impeller unit not to be pressed onto a floor. Then temporary mount the rear casing with the hex. head bolts (901.2).

*Keep the impeller unit free from the load of the split plate or magnet capsule unit.

11. The hex. head bolts (901.2) are going to be tightened at tightening torque when mounting the split plate assembly to the front casing later.

Maintenance

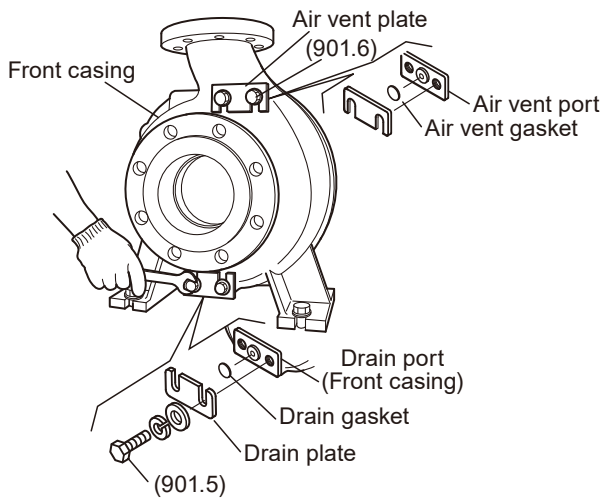

12. Place an air vent gasket and an air vent plate on the air vent port which is positioned on top of the front casing. And fix them with the hex. head bolts (901.6) Place a drain gasket and drain plate on the drain port which is positioned at the bottom of the front casing. And fix them with the hex. head bolts (901.5).

Tightening torque: 20 N·m

*No gasket is provided under the air vent plate or drain plate if an air vent port and a drain port are not open.

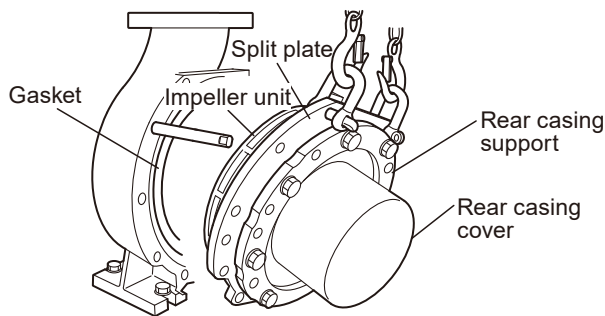

13. Place the gasket in the front casing. If the gasket can't stay in the groove on the front casing, slimly apply fluorine grease so that the gasket can't come off.

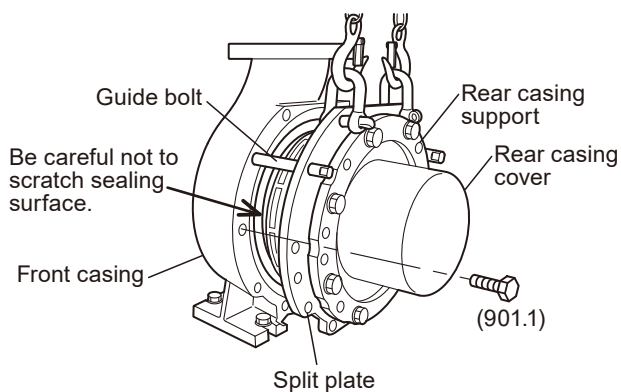

14. Crane and mount the split plate assembly into the front casing and then fix it with hex. head bolts (901.1). Install guide bolts to both sides of the front casing for easy mounting. Do not hit the impeller unit onto the front casing when not using guide bolts.

Maintenance

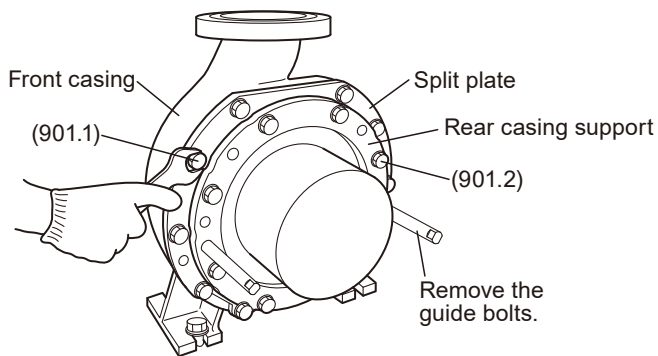

15. Tighten the rear casing support fixing bolts (901.2) and split plate assembly fixing bolts (901.1) at the tightening torque below.

Tightening torque: 100 N·m

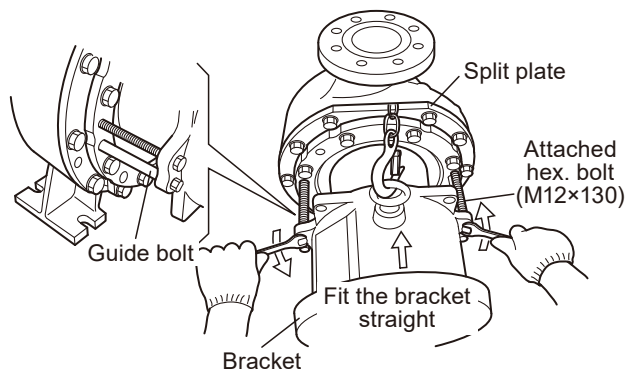

16. Remove the guide bolts and install them on the rear casing support. Take the attached two hexagon bolts (M12×130) and screw them into both upper holes on the bracket edges all the way. Using guide bolts, the bracket can be mounted straight without hitting against the rear casing cover.

17. Crane and mount the bracket into the pump unit.

*Always use guide bolts when mounting the bracket into the pump unit. Be sure to keep the pump unit horizontal.

⚠ CAUTION

Be careful not to catch the finger or hand in between the bracket and the pump unit.

18. Insert the bracket straight into the rear casing support by loosening the attached two hexagon bolts (M12×130) gradually and evenly.

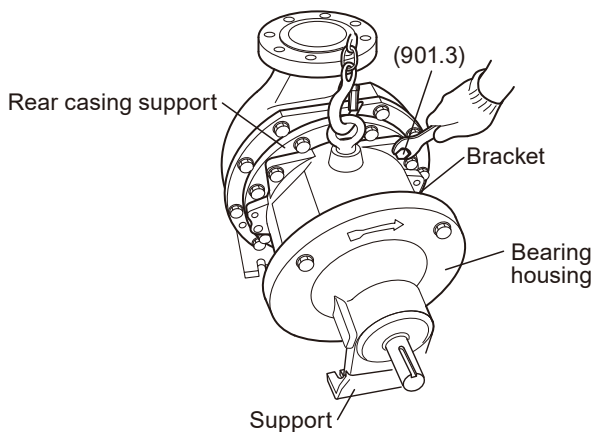

19. Fasten the bracket with the rear casing support using hex. head bolts (901.3).

IWAKI PUMPS



<https://www.iwakipumps.jp>
IWAKI CO.,LTD. 6-6 Kanda-Sudacho 2-chome Chiyoda-ku Tokyo 101-8558 Japan
TEL: +81 3 3254 2935 FAX: +81 3 3252 8892

European Headquarter / IWAKI Europe GmbH
TEL: +49 2154 9254 0 FAX: +49 2154 9254 48

Germany / IWAKI Europe GmbH
TEL: +49 2154 9254 50 FAX: +49 2154 9254 55

The Netherlands / IWAKI Europe GmbH (Netherlands Branch)
TEL: +31 74 2420011 FAX: +49 2154 9254 48

Italy / IWAKI Europe GmbH (Italy Branch)
TEL: +39 0445 561219 FAX: +39 0445 569088

Spain / IWAKI Europe GmbH (Spain Branch)
TEL/FAX: +34 934 741 638

Poland / IWAKI Europe GmbH (East Europe Branch)
TEL: +48 12 347 0755 FAX: +48 12 347 0900

Denmark / IWAKI Nordic A/S
TEL: +45 48 242345

Finland / IWAKI Suomi Oy
TEL: +358 10 201 0490

Norway / IWAKI Norge AS
TEL: +47 23 38 49 00

Sweden / IWAKI Sverige AB
TEL: +46 8 511 72900

Belgium / IWAKI Belgium N.V.
TEL: +32 13 670200 FAX: +32 13 672030

France / IWAKI France S.A.
TEL: +33 1 69 63 33 70 FAX: +33 1 64 49 92 73

U.S.A. / IWAKI America Inc.
TEL: +1 508 429 1440 FAX: +1 508 429 1386

Brazil / IWAKI Do Brasil Comercio De Bombas Hidraulicas LTDA.
TEL/FAX: +55 19 3244 5900

China (Shanghai) / IWAKI Pumps (Shanghai) Co., Ltd.
TEL: +86 21 6272 7502 FAX: +86 21 6272 6929

China (Hong Kong) / IWAKI Pumps Co., Ltd.
TEL: +852 2607 1168 FAX: +852 2607 1000

China (Guangzhou) / GFTZ IWAKI Engineering & Trading Co., Ltd.
TEL: +86 20 84350603 FAX: +86 20 84359181

China (Shenzhen) / IWAKI Pumps (Shenzhen) Co., Ltd.
TEL: +86 0755 8656 3696

Singapore / IWAKI Singapore Pte Ltd.
TEL: +65 6316 2028 FAX: +65 6316 3221

Indonesia / IWAKI Singapore Pte Ltd. (Indonesia Office)
TEL: +62 21 6906606 FAX: +62 21 6906612

Malaysia / IWAKIm SDN. BHD.
TEL: +60 3 7803 8807 FAX: +60 3 7803 4800

Korea / IWAKI Korea Co., Ltd.
TEL: +82 2 6238 4800 FAX: +82 2 6238 4801

Taiwan / IWAKI Pumps Taiwan Co., Ltd.
TEL: +886 2 8227 6900 FAX: +886 2 8227 6818

Thailand / IWAKI (Thailand) Co., Ltd.
TEL: +66 2 322 2471 FAX: +66 2 322 2477

Australia / IWAKI Pumps Australia Pty Ltd.
TEL: +61 2 9899 2411 FAX: +61 2 9899 2421