

IWAKI AX Metering Pump

Electric Servo Unit

Instruction Manual

 Read this manual before use of product

Thank you for selecting the IWAKI METERING PUMP AX Type with Electric Servo Unit. This pump is a process-use pump equipped with an automatic stroke length control unit designated as the "Electric Servo Unit". This instruction manual deals with safety instructions and the correct handling procedures for the servo unit as well as the maintenance & inspection procedures and troubleshooting measures to be taken in the event of failure. Please read through the instructions and be sure to understand the contents fully before using the pump as this will assist you in maximizing the utilization of the performance of pump as well as the safe, effective and long operation of the pump system.

Contents

Important instructions	1
Safety instructions	2
(Safety Instructions to Prevent Personal Injuries)	
1. Unpacking and Inspection	4
2. Outline of Servo Unit	4
3. Specifications	6
4. Wiring	7
5. Operation	9
6. Adjustment	11
7. Causes of Trouble and Troubleshooting	16
8. Structure of Pump and Names of Parts	17



This instruction manual should be kept on hand by the end user for quick reference.

Contact us or your nearest dealer if you have any questions.

Important instructions

For the Safe and Correct Handling of the Pump

- “Safety Instruction” section deals with important details about handling of the product. Before use, read this section carefully for the prevention of personal injury or property damage.
- Observe the instructions accompanied with “WARNING” or “CAUTION” in this manual. These instructions are very important for protecting users from dangerous situations.
- The symbols on this instruction manual have the following meanings:

 WARNING	Nonobservance or misapplication of “Warning” sections could lead to a serious accident which may result in death.
 CAUTION	Nonobservance or misapplication of “Caution” sections could lead to personal injury or property damage.

Types of Symbols



Indicates that “Warning” or “Caution” must be exercised. Inside this triangle, a concrete and practical image provided as a warning or caution message is depicted.



Indicates a prohibited action or procedure. Inside or near this circle, a concrete and practical image of the activity to be avoided is depicted.



Indicates an important action or procedure which must be performed or carried out without fail. Failure to follow the instructions herein can lead to malfunction or damage to the pump.

Export Restrictions

Technical information contained in this instruction manual might be treated as controlled technology in your countries, due to agreements in international regime for export control. Please be reminded that export license/permission could be required when this manual is provided, due to export control regulations of your country.

Safety instructions

WARNING

- **Turn off power before service**

Risk of electrical shock. Be sure to turn off power to stop the pump, servo unit and related devices before service is performed.



Turn off power

- **Do not use a damaged servo unit**

Use of a damaged servo unit could lead to an electric leakage or an electrical shock.



Prohibited

- **Qualified personnel only**

This product should be handled or operated by qualified personnel with a full understanding. Any person not familiar with the product should not take part in the operation or maintenance of the pump and servo unit.



Caution

- **Do not modify the servo unit**

Alterations to the product carry a high degree of risk. It is not the manufacturer's responsibility for any failure or injury resulting from alterations to the servo unit.



Do not rework
or alter

- **Do not use the servo unit in any condition other than its intended purpose**

The use of the servo unit in any conditions other than those clearly specified may result in failure or injury. Use this product in specified conditions only.



Prohibited

- **Do not stand on the servo unit**

Injury or damage may result when the servo unit turns over.



Prohibited

- **Do not touch the control knob or the slide shaft in operation**

Serious injury may result.



Prohibited

Safety instructions

CAUTION

- **Grounding**

Risk of electrical shock! Always properly ground the pump and servo unit. Conform to local electric codes.



- **Use specified power only**

Do not apply power other than that specified on the nameplate. Otherwise, failure, fire or electrical shock may result. Ensure the pump and servo unit are properly grounded.



- **Install a GFCI (earth leakage breaker)**

An electrical failure of the pump or servo unit may adversely affect other devices on the same line. Purchase and install a GFCI (earth leakage breaker) separately.



- **Do not install/store the product:**

- In a flammable/explosive atmosphere.
- Where ambient temperature can exceed 0-40 °C.
- In a dusty/humid environment.
- In wind & rain.
- Under mechanical vibrations.



- **Disposal of a used product**

Dispose of any used or damaged product in accordance with local rules and regulations. If necessary, consult a licensed industrial waste disposal company.



- **Keep labels clean**

If the nameplate or labels have become unglued or illegible, contact us to replace them with new ones.



1. Unpacking and Inspection

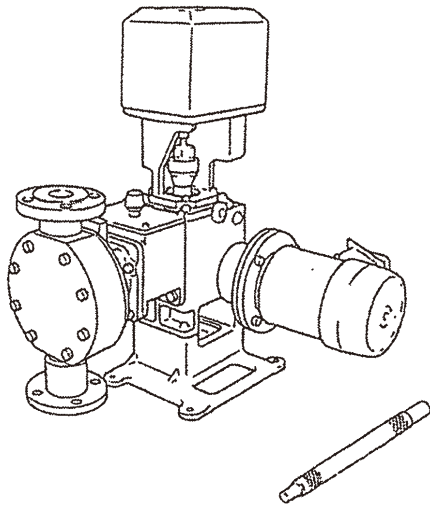

Stroke adjusting tool
(for AXB type only)

For the purpose of confirming that the product delivered corresponds with your order after unpacking, check whether-

- [1] The model code on nameplate is as you ordered.
- [2] A stroke adjusting tool is attached to the product (For AXB type only).
- [3] There is no breakage, deformation and the looseness of bolts/nuts in transit.

2. Outline of Servo Unit

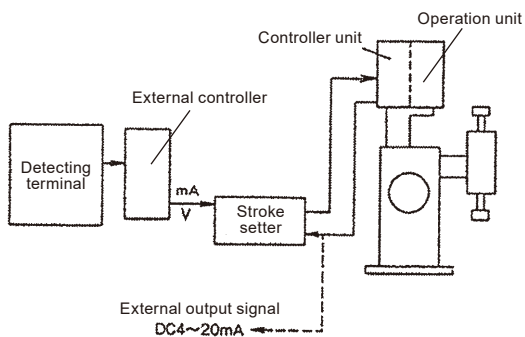
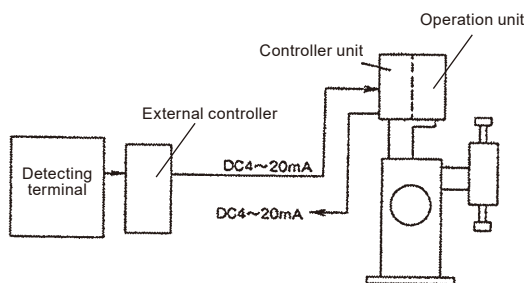

K90 type DC4-8mA
 K120 and K150 types DC4 - 9.33mA
 K180 type DC4 - 10.40mA

The electric Servo Unit for AX Series Metering Pump is a new type of auto stroke length control unit with a built-in positioner. The servo unit consists of an operation unit to perform the stroke length adjustment with a control motor and potentiometer and a controller unit to control the operation unit in accordance with the signals output by such an external device as the PID controller.

With a built-in controller (positioner) installed inside the servo unit, the stroke length over a range of 0 to 100% is directly controlled with a DC4-20mA signal.

The more versatile functions can be added to a system by the use of the servo unit in combination with an optional device, the Stroke Setter ST type.

The Stroke Setter is equipped with such control functions for proportional setting, signal limiting and reverse action as well as a display function for stroke length and I/O signals. For details on the Stroke Setter, refer to the instruction manual of the AX series Stroke Setter.

Note: In case of a direct-acting diaphragm type, the stroke length cannot be controlled directly with a DC4-20mA signal since different signals are used (K90type ...DC4-8mA, K120/K150 types ... DC4-9.33mA, K180 type ...DC4-10.40mA). For direct-acting diaphragm type, use the pump in combination with a Stroke Setter ST type (specially adjusted for the direct-acting type before shipment).

■ Operating principle

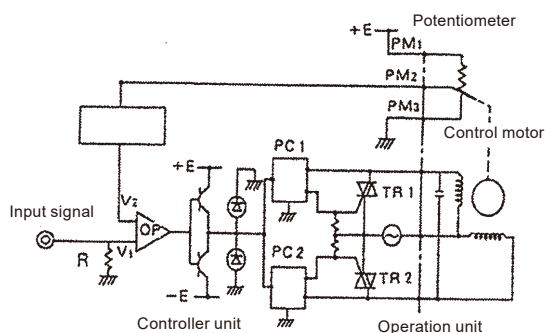

When the input signal enters the servo unit, the signal is converted by resistor R to voltage V_1 to be added as input to the comparative amplifier. This voltage V_1 is then compared with the common voltage V_2 of the potentiometer which is the other input to the OP. The value of this V_2 changes in proportion to the pump stroke length by common voltage (within a voltage range specified by +E in advance) of the potentiometer which detects pump stroke length. The comparative amplifier (OP) compares the V_1 and V_2 voltage and produces as output a plus voltage or a minus voltage. When a plus voltage is output, the PC1 is conducted. On the other hand, if a minus voltage is output, the PC2 is conducted. Thus, each of the TRIAC TR1 or TR2 is turned on by the PC1 or the PC2 for normal or reversed rotation of the control motor.

If $V_1=V_2$ is established, the output of OP becomes zero to stop the motor operation. With such a feedback loop configured, pump operation with a stroke length in proportion to the input signal is realized.

■ Input signal disconnection backup function

The servo unit is designed to operate in proportion to the signal which is inputted externally. If the input signal supply is disconnected due to a failure or a wire disconnection in the external device, the relay within the circuit is activated and the servo unit stops the stroke length at the moment it is stored. The servo unit automatically recovers as soon as the input signal level returns to normal (4-20mA). This input signal disconnection backup function is not available during a reverse action with the use of Iwaki's Stroke Setter (With the input signal disconnected, the pump stroke length grows toward 100%).

3. Specifications

■ Specifications

100VAC 50/60Hz

Specification item		Applicable pump types	
		AXJ • AXK • AXA	AXB
Operation unit	Control motor output	15W	25W
	Control motor rated current	0.33/0.41A	0.55/0.67A
	Capacitor capacity	6 μ F	10 μ F
	Potentiometer resistance	1k Ω	
	Operating time (50/60Hz) * ¹	33/28 sec.(15/13 sec. in the case of a direct-acting diaphragm type)	
Controller unit	Power source * ⁴	100VAC, 50/60 Hz, \pm 10% of voltage fluctuation	
	Input signal	DC4-20mA (K90 type : DC4-8mA, K120/K150 types: DC4-9.33mA, K180 type: DC4-10.40mA)	
	Input resistance	75 Ω	
	Stroke signal output	DC4-20mA (K90 type : DC4-8mA, K120/K150 types: DC4-9.33mA, K180 type: DC4-10.40mA) (Permissible load resistance: 600 Ω or below)	
	Power consumption	40VA	
Common Specifications	Permissible ambient temperature	-5 to 40 deg.C	
	Operating ambient temperature * ²	-15 to 50 deg.C	
	Setting accuracy * ³	\pm 1%FS (Direct-acting diaphragm type : \pm 4%FS) (Within permissible ambient temperature range)	
	Structure	Fully-closed outdoor use type	

*¹ Operating time means the time required to change the stroke length from 0% to the 100% level. It varies slightly with the degree of the pump load.

*² Setting accuracy may be lowered in the operating ambient temperature (-15 to 50 deg.C).

*³ Setting accuracy varies the adjusted sensitivity for the prevention of hunting.

*⁴ A different power supply other than 100VAC is available, for example 200V.

4. Wiring

■ Wiring diaphragm

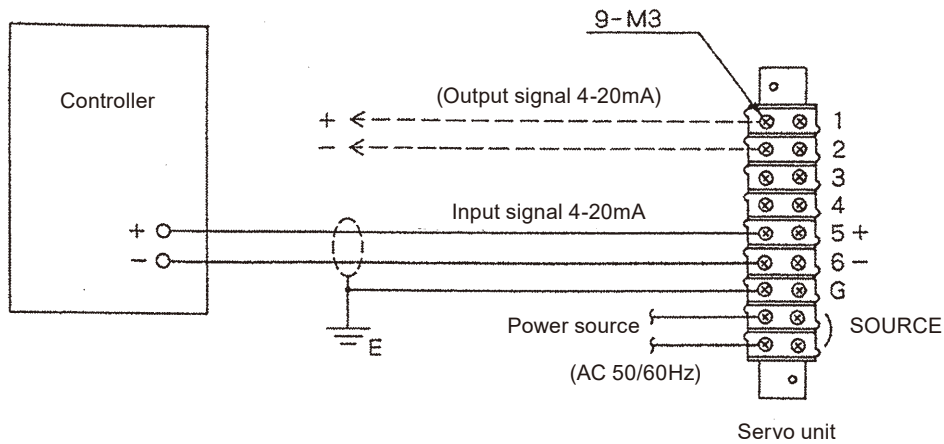

Note: In case of a direct-acting diaphragm type, different input and output signals are used (K90 type: DC4-8mA, K120/K150 types: DC4-9.33mA, K180 type: DC4-10.40mA).
Use the pump in combination with a Stroke Setter ST type.

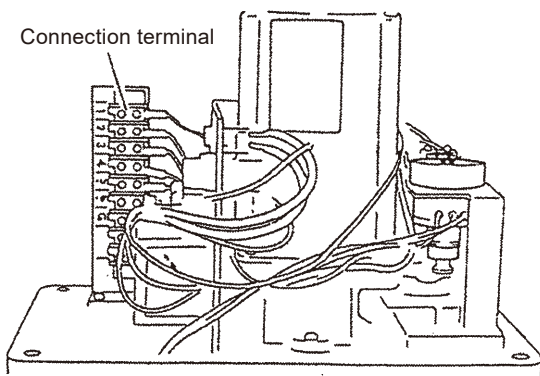
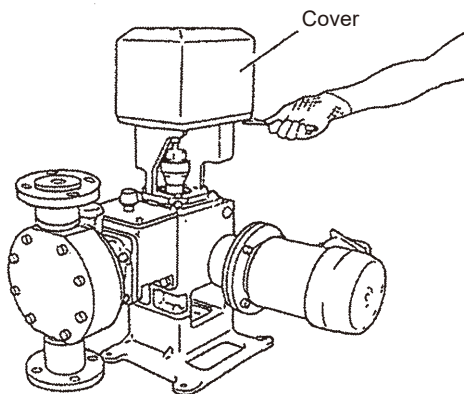

The connection terminals of the servo unit are located inside the servo unit. Open the cover with a wrench and connect the terminals. Match the terminal symbols correctly and connect the cables to the terminal block by the use of a bell mouth.

[1] Arrange the sequence so that the power supply of the controller will turn off at the same time as the pump motor stopping, in order to prevent any overloaded operation of the control motor. In the operation with the Stroke Setter ST type, arrange the Stroke Setter for turning off.

* Even when the pump stroke length is set at 0%, a slight amount of liquid may be discharged out of the pump due to the pump structure. When it is necessary in your particular application to allow no discharge at all at 0% pump stroke length, arrange the sequence so that the pump shall stop at 0% pump stroke length. For information regarding this setting, consult Iwaki.

[2] Make sure to prepare separate bell mouths for the wires of input/output signals (1, 2, 3, 4, 5 and 6) and the wire for power supply (SOURCE). When using conduit tubes, separate those wires used for different purpose.

[3] Use a control cable with an outer diameter of 11mm or less and a cross-section area of 0.5 mm² for the wires (1, 2, 3, 4, 5 and 6) for input/output signals. These cables should be shielded and a grounding should be arranged at one end of the cables.

Note: Terminals No.3 and 4 are used for the combined usage of the optional device, the Stroke Setter.

[4] When using conduit tubes, take appropriate measures not to subject the electric servo unit to the load of the conduit tubes. The connection with the electric servo unit should be flexible.

[5] Current signals of DC4-20mA in proportion to the pump stroke length are output. Connect the cables for output signals as necessary.

<p>Note: Note that the output signals with a direct-acting diaphragm type are different. (Signal converter is required.)</p>
--

[6] After connection, confirm that the power switch inside the servo unit is at ON and attach the cover in place. (The switch is set at the ON position upon shipment from Iwaki's plant.)

*The power switch inside the servo unit is for maintenance purpose only. If it is necessary to turn ON/OFF the servo unit, install an external switch.

5. Operation

The pump and the servo unit are shipped after an adjustment on the specifications that is indicated at order stage. Confirm the following functions before starting the practical usage of the system.

When operating the pump or checking the pump functions, fully open the valves installed on the pump discharge side and suction side piping. Inspect each function while operating the pump.

■ Auto operation

Run the pump as described below, in accordance with the instruction manual of the pump.

[1] Confirmation of functions (Refer to the "Note" regarding a direct-acting diaphragm type.)

- (1) Turn on the power supply of the external controller.
- (2) Set the controller so that an input signal of DC 4mA is sent from the external controller to the controller unit. (If a current generator is available, remove the external controller and supply the input signal by the use of the current generator.)
- (3) Turn on the power supply of the control unit.
- (4) Check the stroke length scale to see that the pump stroke length is set at $0\% \pm 1\%$ under this condition. If the pump stroke length deviates from the range of $0\% \pm 1\%$ at this moment, carry out a zero point adjustment. (Refer to the section dealing with zero point adjustment.)
- (5) Next, set the external controller so that an input signal of DC20mA is sent from the external controller to the controller unit.
- (6) Check the stroke length scale to see that the pump stroke length is set at $100\% \pm 1\%$ under this condition. If the pump stroke length deviates from the range of $100\% \pm 1\%$ at this moment, carry out a span adjustment. (Refer to the section dealing with span adjustment.)
- (7) Repeat the above steps (2) to (6) for the adjustment and the confirmation of the scale reading.
- (8) Carry out a setting accuracy inspection as described below after the zero point and span checks. Increase the signal from DC 4mA to 20mA in an increment of 4 mA, then decrease it down to DC 4mA again. While changing the current, read the pump stroke length relative to the signal current level to confirm the setting accuracy.
- (9) Confirm that no hunting phenomenon occurs at the intermediate stroke length selected. If hunting occurs, adjust the sensitivity. (Refer to the section dealing with sensitivity adjustment.)

Note: Regarding a direct-acting diaphragm type, confirm the action with the combined use of a stroke setter. In this case, the signal from the external controller shall be inputted to the stroke setter. The setting accuracy in the above steps(4) and (6) shall be $\pm 4\%$ FS.
If the servo unit is to be adjusted independently, refer to section 6 "Adjustment."

[2] Operation

Start a practical operation of the pump system in accordance with the following steps, after confirming the normal functions of the servo unit.

- (1) Attach the cover of the servo unit in position.
- (2) Send an input signal from the external controller to the controller unit.
- (3) Start the pump in accordance with the instruction manual.
- (4) Supply power to the controller unit to start operation.

■ Operation without servo unit

In the event of failure in the signal system or the like, the pump can be operated by the manual stroke length adjustment. Operate and adjust the pump as described below in such a case.

[1] Turn off the power of the controller unit of the servo unit.

Turn off the power of the controller unit when adjusting the stroke length manually. Turning the dial for adjusting the stroke length while power is being supplied may activate the control motor which may cause a serious accident.

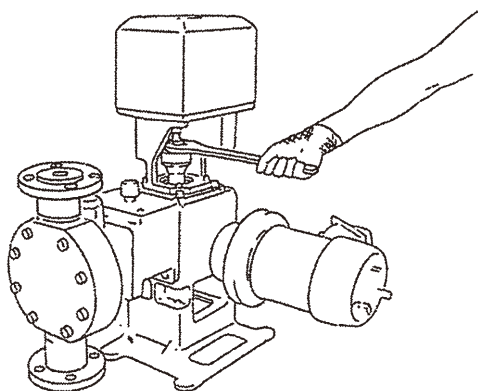

AXJ, AXK and AXA types

[2] Use a wrench (with a clearance of 36 mm) or a stroke-length adjusting tool (a special tool is provided with the AXB type) to rotate the slide shaft on the control knob on the pump. Then, adjust the stroke length as specified in the instruction manual of the pump.

Note: When adjusting the stroke length manually, make sure not to exceed the adjustment range of the limit switch. (Refer to the section dealing with the adjustment of the limit switch.)

[3] Start the pump in accordance with the pump's instruction manual.

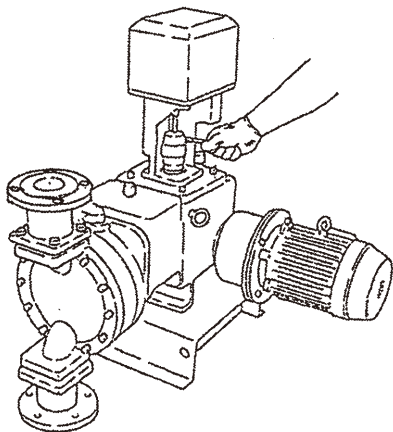

AXB type

6. Adjustment

■ Names and functions of parts in controller unit

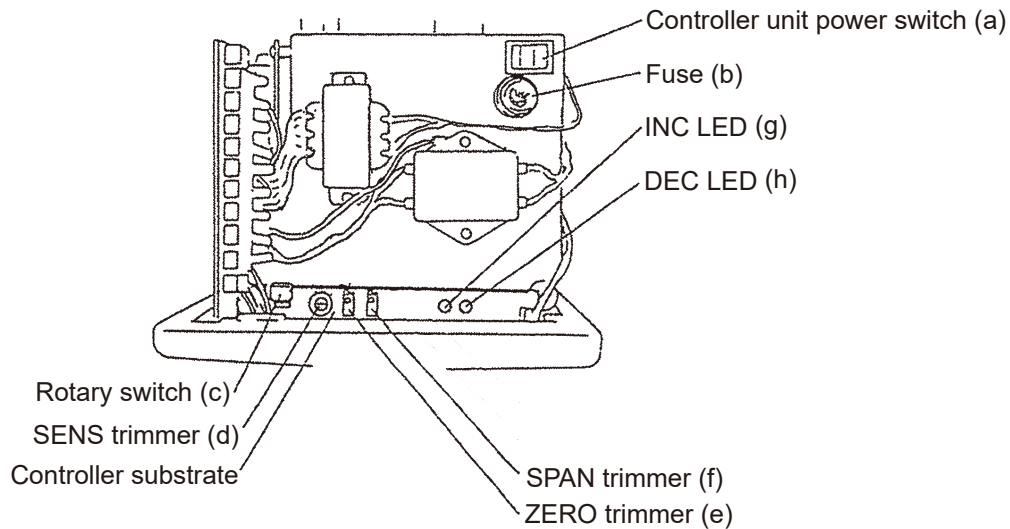

(a) Controller unit power switch

This power switch for the controller unit is used only for maintenance purposes. Under normal conditions, the switch shall be kept at the ON position.

(b) Fuse

This is a fuse for the controller unit.

(c) Rotary switch

This switch is operated to adjust a constant such as voltage and/or pump type. This switch is set according to the pump type before shipment. Do not touch it.

0: AXA-K(KE) and AXB-K(KE) types (Direct-acting diaphragm types)

1: AXJ type

2: AXK type

3: AXA type

4: AXB type

(d) SENS (sensitivity) trimmer

Rotating this trimmer clockwise increases the sensitivity, while rotating it counter-clockwise decreases the sensitivity. Rotate it counter-clockwise direction to stop hunting.

(e) ZERO trimmer

Rotating this trimmer clockwise decreases the stroke length.

(f) SPAN trimmer

Rotating this trimmer counter-clockwise increases the stroke length.

(g) INC LED (orange)

Turns on as stroke length increases.

(h) DEC LED (green)

Turns on as stroke length decreases.

[Adjustment of Controller Unit]

The controller unit is adjusted by Iwaki before shipment. Each user needs not adjust it. However, if the setting accuracy deviates remarkably, the controller unit shall be adjusted in accordance with the steps described below:

Note: The value in [] shall be employed for the adjustment of a direct-acting diaphragm type.

■ Preparation

- [1] Remove the cover.
- [2] Connect the current generator to terminals 5(+) and 6(-).
- [3] Fully open the valves on the pump discharge side and on the suction piping and adjust them while running the pump.
- [4] Turn on the power of the external controller and the current generator.

■ Sensitivity adjustment

Sensitivity adjustment refers to the adjustment of the sensitivity (dead zone) of the controller unit. Decreased sensitivity can prevent the hunting of the signal system and the hunting of the positioner itself. However, this adjustment is completed by Iwaki before shipment. Do not try to adjust the sensitivity.

■ Zero point adjustment

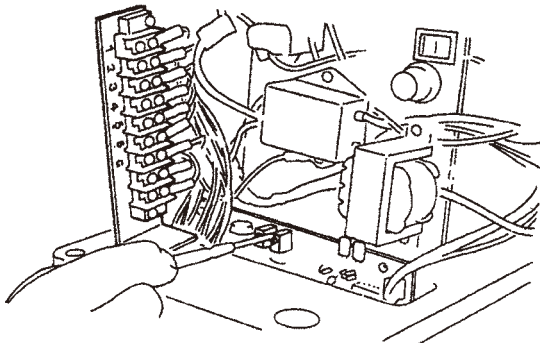

- Adjust the ZERO trimmer on the controller substrate as described below so that the pump stroke length will be 0% when the DC 4mA signal is input
- (1) Input the DC 4mA signal from the current generator.
 - (2) Rotate the ZERO trimmer clockwise to turn on the DEC LED (green).
 - (3) Slowly rotate the ZERO trimmer counter-clockwise until the DEC LED (green) goes out.

Note: Rotating the trimmer counter-clockwise excessively causes the stroke length to change (increase). Make sure the pump stroke length reading meets the following stroke length range, after the completion of the zero point adjustment.

0 to -0.2%

[K90 type.....0 to -0.8%,

K120/K150 types.....0 to -0.6%

K180 type.....0 to -0.5%]

■ Span adjustment

Adjust the SPAN trimmer on the controller substrate as described below so that the pump stroke length will be 100% when the DC 20mA signal is input.

- (1) Input the DC 20.00 mA signal from the current generator.
- (2) Rotate the SPAN trimmer counter-clockwise to turn on the INC LED (orange).
- (3) Slowly rotate the SPAN trimmer clockwise until the INC LED (orange) goes out.

Note: Rotating the trimmer clockwise excessively causes the stroke length to change (decrease).

Make sure the pump stroke length reading meets the following stroke length range, after the completion of the span adjustment.

100 to 100.2%

[K90 type.....100 to 100.8%, K120/K150 types.....100 to 100.6%, K180 type.....100 to 100.5%]

■ Special notes for adjustment

- [1] When carrying out the ZERO adjustment or the SPAN adjustment, either one of them may cause poor adjustment accuracy in the other. Both the ZERO and the SPAN adjustments shall be repeated alternatively for the balanced results between them.
- [2] Make sure to check the accuracy after each adjustments. Note that the sensitivity accuracy will be lower than the specified level when sensitivity is lowered in the adjustment.

[Adjustment of Operation Unit]

■ Adjustment of potentiometer

For the adjustment of the potentiometer, remove the cover of the servo unit and follow the steps described below. The number in () indicates each part No. Refer to "(8) Structure of Pump and Names of Parts". Do not run a current higher than 35 mA on the potentiometer. Adjust the potentiometer when replacing or removing the electric servo unit from the pump.

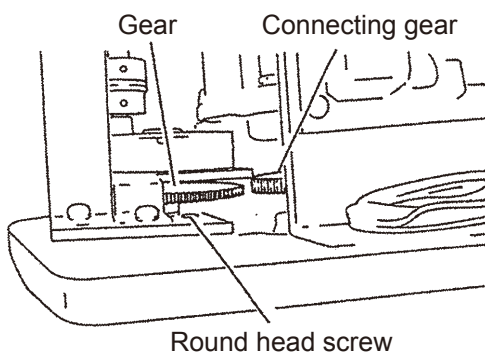

- [1] Set the pump stroke length at 0%, remove the round head ⊕ screw (329), and slide the potentiometer assembly to disengage the connecting gear (333) from the gear (325).

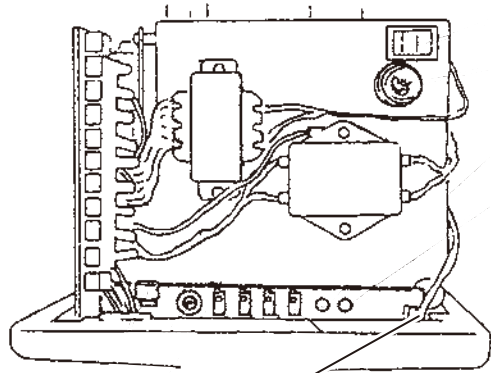

A connector joins the lead wires of the potentiometer.

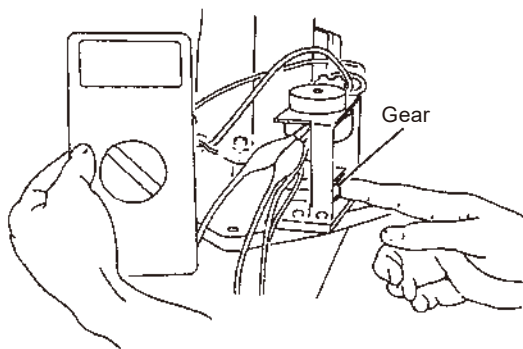

- [2] Remove the lead wire of the potentiometer, which is connected onto the controller substrate with a connector.
 - When wires are to be removed from the controller unit, make sure to confirm each position to prevent a mistake in reconnecting them later.
- [3] Measure the resistance across terminals 1 and 2 (the red terminal and the center terminal) of the potentiometer with a tester.
- [4] Rotate the gear (325) so that the resistance value will be $75 \pm 5 \Omega$.
- [5] While observing the resistance value on the potentiometer, engage the gear which was disengaged in step [1] above. Then, fasten the round head \oplus screw (329).
- [6] Attach the connector which was removed in step [2] above on the controller substrate. Now the adjustment of the potentiometer is completed.

■ Adjustment of limit switch

- [1] Connect the generator to terminals 5(+) and 6(-) on the terminal block. Then confirm that the limit switch functions are at the correct position, in accordance with the steps described below:
 - (1) Turn on the power of the controller unit.
 - (2) Input the 3.8 mA current signal from the generator to confirm that the stroke length reading is approx. 0%.
 - (3) Input the 21 mA current signal from the generator [K90 type.....8.5 mA, K120 and K150 types.....10 mA, K180 type.....11 mA] to confirm the stroke length reading is approx. 100%.
 If each reading deviates remarkably from the specified level, carry out the following adjustment:
- [2] Adjust the position of the lower limit cam (302, lower) so that the lower limit switch (307, lower) will be activated when the stroke length reading is 0 to -0.2% [K90 type.....0 to -0.8%, K120/K150 types.....0 to -0.6%, K180 type.....0 to -0.5%]. Then fasten the set screw (305).
- [3] Adjust the position of the upper limit cam (302, upper) so that the upper limit switch (307, upper) will be activated when the stroke length reading is 100 to 100.2% [K90 type.....100 to 100.8%, K120/K150 types.....100 to 100.6%, K180 type.....100 to 100.5%]. Then fasten the set screw (305).

After the completion of the adjustment of the limit switch, carry out the adjustment of the controller unit.

■ Removal of the servo unit from the pump

When it is necessary for the adjustment of the pump or the like, remove the servo unit in accordance with the following steps.

- [1] Set the pump stroke length at 0%, then stop the pump.
- [2] Turn off the power of the controller and the current supply for controlling purposes.
- [3] Remove all the wires connected to the terminal block of the servo unit from outside.
- [4] Remove the hex bolt (372) and lift the servo unit to remove it.

■ Assembling and adjustment

When installing the servo unit back onto the pump, carry out the steps of removal in reverse while paying attention to the following points:

- [1] To mount the servo unit on the pump, place the spring pin (369) of the slide shaft in the slot in the connecting shaft (331). Apply grease to the slot, too.

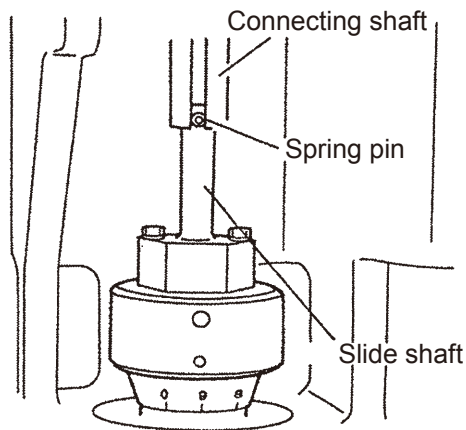

- [2] If the slide shaft (368) has been disconnected from the control knob on the pump, first set the stroke length at 100% and align it with the connecting shaft (331), then fasten the hex. bolt (370). After that, set the stroke length at 0%. Confirm that the stroke length is at 0% with the servo unit attached onto the pump. Then, carry out the adjustment of the potentiometer and the limit switch. (Refer to the section dealing with the adjustment of the operation unit.)

7. Causes of Trouble and Troubleshooting

Trouble	Causes	Troubleshooting
Control motor dose not run.	<ul style="list-style-type: none"> • Power is not supplied to the controller unit. • Disconnection or poor connection in the controller unit circuit. • Faulty wiring • Thermostat of the motor is activated. • Motor capacitor is out of order. 	<ul style="list-style-type: none"> • Turn on the switch inside the servo unit. • Check power voltage. • Check the circuit and repair as necessary. • Inspect the wiring. • Remove the cause of the temperature rise. • Replace the capacitor (352).
Operation is limited to one direction.	<ul style="list-style-type: none"> • Disconnection or poor connection in wiring. • Limit switch is out of order. • Disconnection or poor connection in the controller unit circuit. 	<ul style="list-style-type: none"> • Inspect the wiring. • Replace the limit switch (307). • Check the circuit and repair as necessary.
Stroke length range from 0 to 100% is not accurately available.	<ul style="list-style-type: none"> • Poor adjustment of the trimmer in the controller unit. • Poor setting of the potentiometer • Poor setting of the limit switches for the upper and lower limits 	<ul style="list-style-type: none"> • Carry out adjustment of the controller unit. • Readjust the potentiometer. • Readjust the limit switches.
Controller motor runs but setting accuracy is not stabilized.	<ul style="list-style-type: none"> • Potentiometer is out of order. • Screw on the coupling (314) is loose. • Electric signal is not stable. • Hunting is generated. • Faulty connection in the terminal or the circuit. • External noise has entered the signal line. • Driving gear is out of order. 	<ul style="list-style-type: none"> • Replace the potentiometer (312). • Fasten the coupling onto the shaft firmly. • Input stable signals only. • Adjust the sensitivity trimmer in the controller unit to lower the sensitivity. • Correct the wiring. • Use a shielded wire and make certain one of the ends is grounded. Separate the current signal lines (1-6) from those for the power supply purpose (source). • Contact Iwaki or your distributor.

8. Structure of Pump and Names of Parts

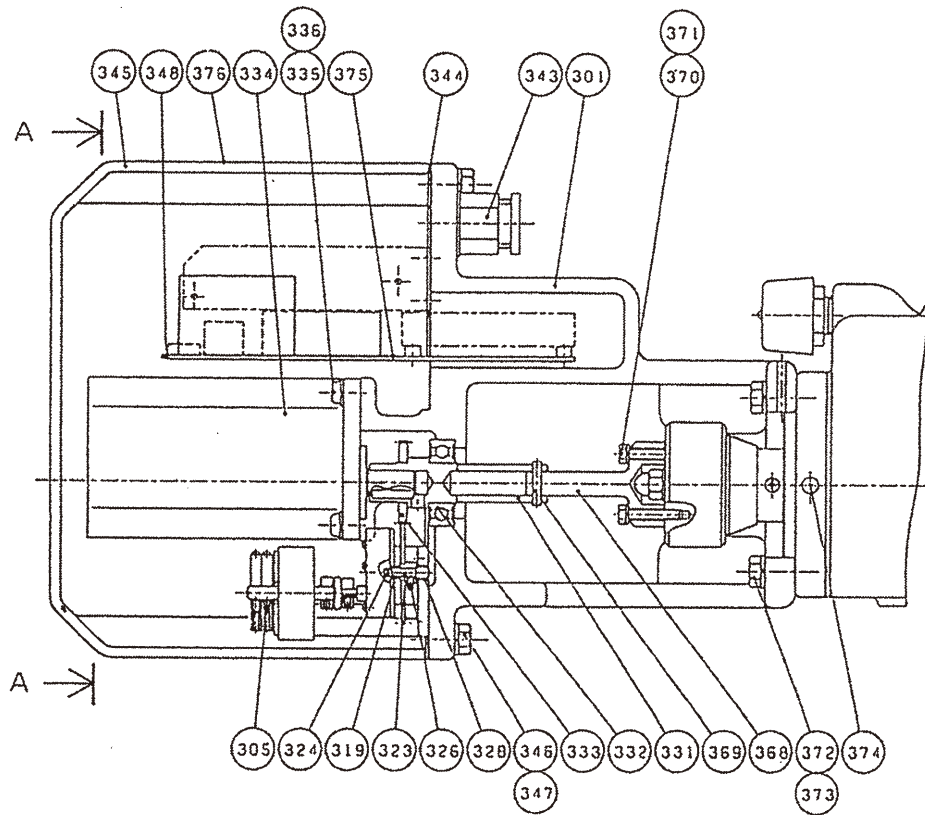

A-A cross section

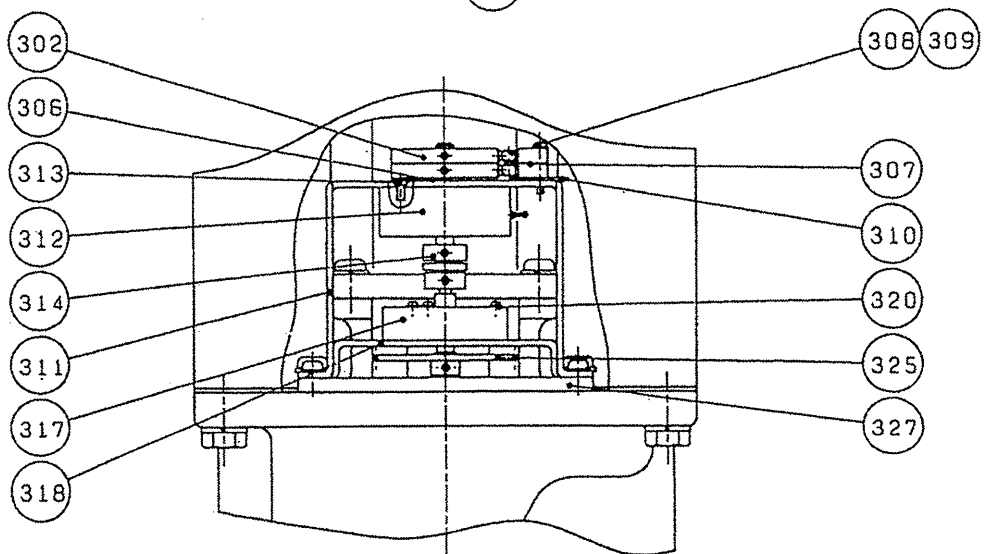
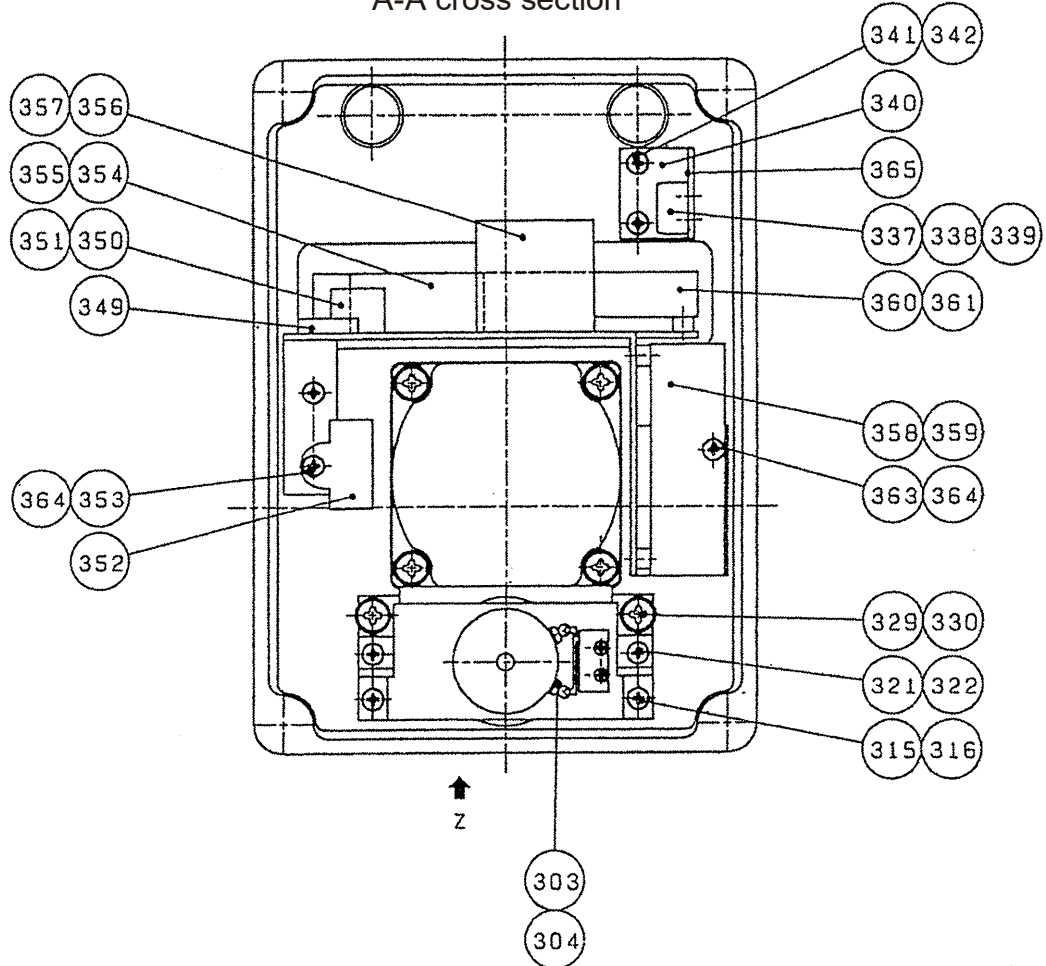

View in Z direction

No.	Name	Q'ty	No.	Name	Q'ty
301	Bracket	1	338	Round head screw	2
302	Limit cam	2	339	Spring washer	2
303	Round head screw	2	340	Stay	1
304	Spring washer	2	341	Round head screw	2
305	Set screw	2	342	Spring washer	2
306	Packing spacer	1	343	Bell mouth	2
307	Limit switch	2	344	Gasket	1
308	Round head screw	2	345	Cover	1
309	Spring washer	2	346	Hex bolt	4
310	Seat A	1	347	Spring washer	4
311	Limit support	1	348	Chassis	1
312	Potentiometer	1	349	Switch	1
313	Round head screw	3	350	Fuse	1
314	Coupling	1	351	Fuse holder	1
315	Round head screw	2	352	Capacitor	1
316	Spring washer	2	353	Round head screw	1
317	Gear head	1	354	Noise filter	1
318	Gear support	1	355	Round head screw	2
319	DU bush	1	356	Transformer	1
320	Spring washer	3	357	Round head screw	2
321	Round head screw	2	358	Power source substrate	1
322	Spring washer	2	359	Round head screw	4
323	Gear shaft	1	360	Control substrate	1
324	Pinion	1	361	Round head screw	4
325	Gear	1	363	Round head screw	2
326	Set screw	1	364	Spring washer	3
327	Geared spacer	1	365	Nameplate "display (trimmer)"	1
328	DU bush	1	368	Slide shaft	1
329	Round head screw	2	369	Spring pin	1
330	Spring washer	2	370	Hex bolt	2
331	Connecting shaft	1	371	Spring washer	2
332	Deep-groove ball bearing	1	372	Hex bolt	4
333	Connecting gear	1	373	Spring washer	4
334	Geared motor	1	374	Insert-type bumper	1
335	Round head screw	4	375	Nameplate "display (trimmer)"	1
336	Spring washer	4	376	Nameplate "caution"	1
337	Terminal block	1			



<https://www.iwakupumps.jp>

IWAKI CO.,LTD. 6-6 Kanda-Sudacho 2-chome Chiyoda-ku Tokyo 101-8558 Japan
TEL: +81 3 3254 2935 FAX: +81 3 3252 8892

European Headquarter / IWAKI Europe GmbH
TEL: +49 2154 9254 0 FAX: +49 2154 9254 48

Germany / IWAKI Europe GmbH
TEL: +49 2154 9254 50 FAX: +49 2154 9254 55

The Netherlands / IWAKI Europe GmbH (Netherlands Branch)
TEL: +31 74 2420011 FAX: +49 2154 9254 48

Italy / IWAKI Europe GmbH (Italy Branch)
TEL: +39 0445 561219 FAX: +39 0445 569088

Spain / IWAKI Europe GmbH (Spain Branch)
TEL/FAX: +34 934 741 638

Poland / IWAKI Europe GmbH (East Europe Branch)
TEL: +48 12 347 0755 FAX: +48 12 347 0900

Denmark / IWAKI Nordic A/S
TEL: +45 48 242345

Finland / IWAKI Suomi Oy
TEL: +358 10 201 0490

Norway / IWAKI Norge AS
TEL: +47 23 38 49 00

Sweden / IWAKI Sverige AB
TEL: +46 8 511 72900

Belgium / IWAKI Belgium N.V.
TEL: +32 13 670200 FAX: +32 13 672030

France / IWAKI France S.A.
TEL: +33 1 69 63 33 70 FAX: +33 1 64 49 92 73

U.S.A. / IWAKI America Inc.
TEL: +1 508 429 1440 FAX: +1 508 429 1386

Brazil / IWAKI Do Brasil Comercio De Bombas Hidraulicas LTDA.
TEL/FAX: +55 19 3244 5900

China (Shanghai) / IWAKI Pumps (Shanghai) Co., Ltd.
TEL: +86 21 6272 7502 FAX: +86 21 6272 6929

China (Hong Kong) / IWAKI Pumps Co., Ltd.
TEL: +852 2607 1168 FAX: +852 2607 1000

China (Guangzhou) / GFTZ IWAKI Engineering & Trading Co., Ltd.
TEL: +86 20 84350603 FAX: +86 20 84359181

China (Shenzhen) / IWAKI Pumps (Shenzhen) Co., Ltd.
TEL: +86 0755 8656 3696

Singapore / IWAKI Singapore Pte Ltd.
TEL: +65 6316 2028 FAX: +65 6316 3221

Indonesia / IWAKI Singapore Pte Ltd. (Indonesia Office)
TEL: +62 21 6906606 FAX: +62 21 6906612

Malaysia / IWAKIm SDN. BHD.
TEL: +60 3 7803 8807 FAX: +60 3 7803 4800

Korea / IWAKI Korea Co., Ltd.
TEL: +82 2 6238 4800 FAX: +82 2 6238 4801

Taiwan / IWAKI Pumps Taiwan Co., Ltd.
TEL: +886 2 8227 6900 FAX: +886 2 8227 6818

Thailand / IWAKI (Thailand) Co., Ltd.
TEL: +66 2 322 2471 FAX: +66 2 322 2477

Australia / IWAKI Pumps Australia Pty Ltd.
TEL: +61 2 9899 2411 FAX: +61 2 9899 2421